

Алматы (7273)495-231  
Ангарск (3955)60-70-56  
Архангельск (8182)63-90-72  
Астрахань (8512)99-46-04  
Барнаул (3852)73-04-60  
Белгород (4722)40-23-64  
Благовещенск (4162)22-76-07  
Брянск (4832)59-03-52  
Владивосток (423)249-28-31  
Владикавказ (8672)28-90-48  
Владимир (4922)49-43-18  
Волгоград (844)278-03-48  
Вологда (8172)26-41-59  
Воронеж (473)204-51-73  
Екатеринбург (343)384-55-89

Ижевск (3412)26-03-58  
Иваново (4932)77-34-06  
Иркутск (395)279-98-46  
Казань (843)206-01-48  
Калининград (4012)72-03-81  
Калуга (4842)92-23-67  
Кемерово (3842)65-04-62  
Киров (8332)68-02-04  
Коломна (4966)23-41-49  
Кострома (4942)77-07-48  
Краснодар (861)203-40-90  
Красноярск (391)204-63-61  
Курск (4712)77-13-04  
Курган (3522)50-90-47  
Липецк (4742)52-20-81

Магнитогорск (3519)55-03-13  
Москва (495)268-04-70  
Мурманск (8152)59-64-93  
Набережные Челны (8552)20-53-41  
Нижний Новгород (831)429-08-12  
Новокузнецк (3843)20-46-81  
Ноябрьск (3496)41-32-12  
Новосибирск (383)227-86-73  
Ноябрьск (3496)41-32-12  
Омск (3812)21-46-40  
Орел (4862)44-53-42  
Оренбург (3532)37-68-04  
Пенза (8412)22-31-16  
Петрозаводск (8142)55-98-37  
Псков (8112)59-10-37

Пермь (342)205-81-47  
Ростов-на-Дону (863)308-18-15  
Рязань (4912)46-61-64  
Самара (846)206-03-16  
Саранск (8342)22-96-24  
Санкт-Петербург (812)309-46-40  
Саратов (845)249-38-78  
Севастополь (8692)22-31-93  
Симферополь (3652)67-13-56  
Смоленск (4812)29-41-54  
Сочи (862)225-72-31  
Ставрополь (8652)20-65-13  
Сыктывкар (8212)25-95-17  
Сургут (3462)77-98-35  
Тамбов (4752)50-40-97

Тверь (4822)63-31-35  
Тольятти (8482)63-91-07  
Томск (3822)98-41-53  
Тула (4872)33-79-87  
Тюмень (3452)66-21-18  
Улан-Удэ (3012)59-97-51  
Ульяновск (8422)24-23-59  
Уфа (347)229-48-12  
Хабаровск (4212)92-98-04  
Чебоксары (8352)28-53-07  
Челябинск (351)202-03-61  
Череповец (8202)49-02-64  
Чита (3022)38-34-83  
Якутск (4112)23-90-97  
Ярославль (4852)69-52-93

Киргизия (996)312-96-26-47

Россия (495)268-04-70

Казахстан (772)734-952-31

<https://kls.nt-rt.ru> || [kfs@nt-rt.ru](mailto:kfs@nt-rt.ru)

## Каталог на аксессуары



Electrosurgery

Zubehör für die Hochfrequenzchirurgie  
Accessories for Electrosurgery  
Accesorios para la electrocirugía  
Accessoires électrochirurgicaux  
Accessori per elettrochirurgia

**max. 134 °C**

Hinweis zur Sterilisation:

Unsere wiederverwendbaren Produkte werden im unsterilen Zustand angeliefert und können bei max. 134 °C sterilisiert werden. Einmalprodukte sind hiervon ausgenommen und entsprechend gekennzeichnet.

Note on sterilization:

Our reusable products are supplied in non-sterile condition and can be sterilized at 134°C max. Single-use products are excluded from this and are labeled accordingly.

Nota sobre la esterilización:

Nuestros productos reutilizables se suministran no estériles y se pueden esterilizar a una temperatura máxima de 134 °C. Quedan excluidos de ello los productos desechables que están etiquetados correspondientemente.

Remarque relative à la stérilisation :







Nos produits réutilisables sont fournis à l'état non stérile et peuvent être stérilisés à 134 °C max. Les produits à usage unique en sont exclus et sont marqués en conséquence.

Nota relativa alla sterilizzazione:

I nostri prodotti riutilizzabili sono forniti non sterili e possono essere sterilizzati ad una temperatura massima di 134 °C. Sono esclusi dalla sterilizzazione i prodotti monouso, opportunamente contrassegnati.

Inhalt  
Index  
Indice  
Index  
Indice



1 7-23		Monopolare Elektroden-Handgriffe Monopolar electrode handles Mangos porta-electrodos monopolares Manches porte-électrodes monopolaires Manici portaelettrodi monopolari
2 25-47		Monopolare Elektroden Monopolar electrodes Electrodos monopolares Electrodes monopolaires Elettrodi monopolari
3 49-57		Neutralelektroden Neutral electrodes Placas neutras Electrodes neutres Elettrodi neutri
4 59-87		Bipolares Zubehör Bipolar accessories Accesorios bipolares Accessoires bipolaires Accessori bipolari
5 89-111		Instrumentarium zur bipolaren Gefäßversiegelung Instruments for bipolar vessel sealing Instrumentos para el sellado vascular bipolar Instruments pour la clampage vasculaire bipolaire Strumenti di sigillatura vascolare bipolare
6 113-129		Anschlusskabel und Adapter Connection cables and adapters Cables de conexión y adaptadores Câbles de raccordement et adaptateurs Cavi di connessione e adattatori
7 131-145		Argon-Beamer-System Argon Beamer System Sistema Argon Beamer Système Argon Beamer Sistema Argon Beamer

**8**  
147-157



Rauchgasabsaugung und Zubehör  
Smoke evacuator and accessories  
Evacuación de gases de combustión y accesorios  
Évacuateur de fumée et accessoires  
Aspiratore di fumo e accessori

**9**  
159-170



Hochfrequenzchirurgie-Geräte  
Electrosurgery units  
Aparatos electroquirúrgicos  
Bistouris électrochirurgicaux  
Apparecchi elettrochirurgici

**10**  
171-181



Fußschalter  
Foot switches  
Interruptores de pie  
Interrupteurs à pédale  
Interruttori a pedale

**11**  
183-184



Netzkabel  
Mains cables  
Cables de conexión a la red  
Câbles d'alimentation réseau  
Cavi d'alimentazione della rete

**12**  
185-191



Fahrgestelle  
Trolleys  
Soportes móviles  
Chariots  
Carrelli

**13**  
193-220



Zubehörsätze  
Accessory sets  
Juegos de accesorios  
Jeux d'accessoires  
Serie di accessori

**14**  
221-225

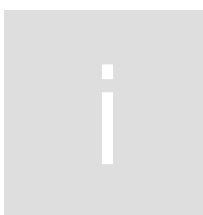

Nummern-Index  
Index of order numbers  
Índice de números de referencia  
Index numérique des références de commande  
Elenco dei codici

Monopolare Elektroden-Handgriffe  
Monopolar electrode handles  
Mangos porta-electrodos monopolares  
Manches porte-électrodes monopolaires  
Manici portaelettrodi monopolari

1

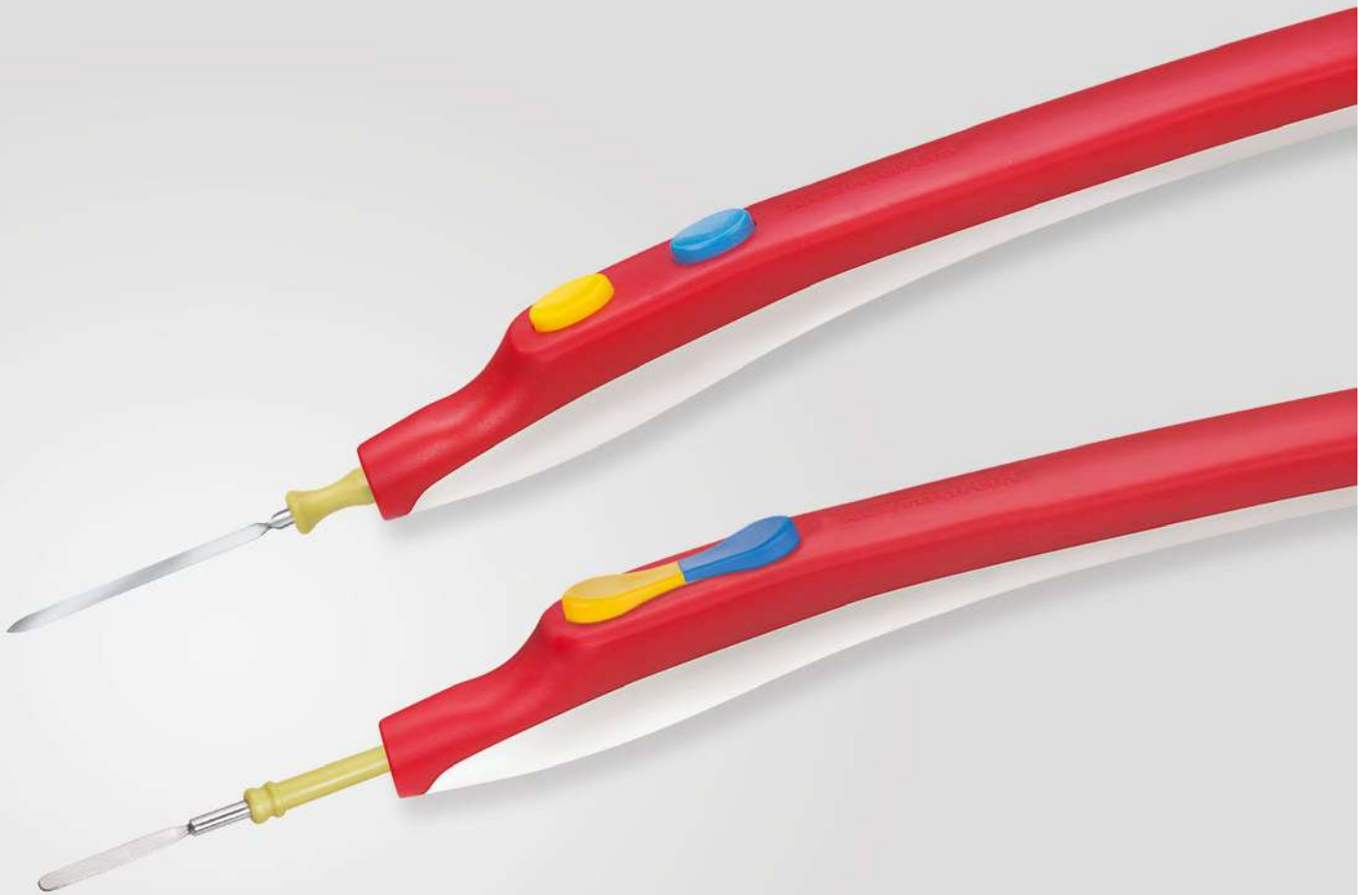

Monopolare Elektroden-Handgriffe.  
Touch and feel the difference!

Monopolar electrode handles.  
Touch and feel the difference!

Los mangos de electrodos monopolares.  
Toquelos y sienta la diferencia!

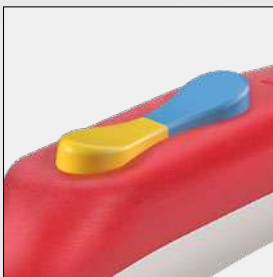

Aktivierung von Cut und Coag  
Cut and Coag activated  
Activación de Cut y Coag  
Activation Coupe et Coag  
Attivazione di Cut e Coag

Hochwertige Materialien  
Premium quality materials  
Materiales de primera calidad  
Matériaux de haute qualité  
Materiali di alta qualità

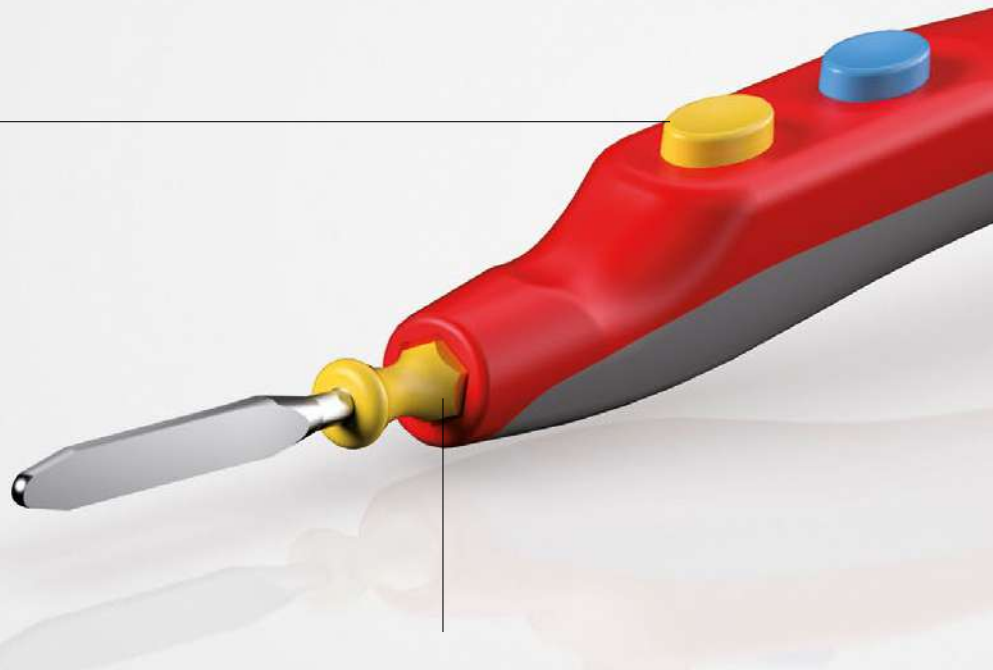

Die Öffnungen sind Bestandteil des Reinigungskonzeptes und stellen sicher, dass kleinste Mengen an Flüssigkeit während des Reinigungsprozesses wieder abfließen können.

The openings are part of the cleaning concept and ensure that the smallest amounts of liquid can be drained off during the cleaning process.

Las orificios son parte del concepto de limpieza y aseguran que las cantidades más pequeñas de líquido pueden ser drenadas de nuevo durante el proceso de limpieza.

Les ouvertures font partie du concept de nettoyage et s'assurent que les plus petites quantités de liquide peuvent être drainées pendant le processus de nettoyage.

Le aperture fanno parte del concetto di pulizia ed assicurano che le più piccole quantità di liquido possano essere scolate indietro durante il processo di pulizia.

Elektrodenaufnahme für Elektroden  
Electrode connection for electrodes  
Soporte de electrodos  
Orifice d'insertion de l'électrode  
Portaelettrodi  
Ø 4,0, 2,4, 1,6 mm



Manches d'électrodes monopolaires.  
Touchez et ressentez la différence!

Manici monopolari per elettrodi.  
Provate la differenza!

1

Knickschutz  
Anti-kink grommet  
Protección contra doblamiento  
Protection anti-torsion  
Guaina di protezione

Hochwertiges Kabel, 4 m  
Premium quality cord, 4 m  
Cable de primera calidad, 4 m  
Câble de haute qualité, 4 m  
Cavo di alta qualità, 4 m

Unterschiedliche Gerätestecker  
Different plugs  
Diferentes enchufes macho  
Différentes fiches  
Diversi connettori

Ergonomisch tailliert  
Ergonomically tailored  
Ergonómico y entallado  
Profil ergonomique  
Linea ergonomica

Hochwertige Weichteilkomponente  
Premium quality pliant component  
Componente de material blando  
de primera calidad  
Partie souple de grande qualité  
Componenti per tessuti molli  
di alta qualità

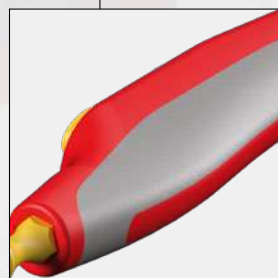



Monopolare Elektroden-Handgriffe  
Monopolar electrode handles  
Mangos porta-electrodos monopolares  
Manches porte-électrodes monopolaires  
Manici portaelettrodi monopolari

smartPen

Passend für **maXium®/maXium® smart C/ME 411/ME 401/ME 400/ME 200**  
Suitable for **ME MB 3/ME MB 2/ME MB 1/ME M1/ME 102**  
Para  
Pour  
Per

Ø 4 mm



80-217-13-04 *max. 6300 Vp*

**KLS Martin**

Elektroden-Handgriff mit zwei Tasten, großem Koax-Stecker und fest angeschlossenem 4 m Kabel  
Electrode handle with two pushbuttons, large coax plug and permanent cord of 4 m  
Mango porta-electrodos con dos teclas, clavija coaxial grande y cable de conexión fija de 4 m  
Manche porte-électrode avec interrupteur digital double, grande fiche coax et câble de raccordement fixe de 4 m  
Manico portaelettrodi con due tasti, spina coassiale grande e cavo di connessione fisso da 4 m

Ø 4 mm



80-210-13-04 *max. 6300 Vp*

**KLS Martin/Erbe intern. Version/Valleylab**

Elektroden-Handgriff mit zwei Tasten, 3-Pin-Stecker und fest angeschlossenem 4 m Kabel  
Electrode handle with two pushbuttons, 3-pin plug and permanent cord of 4 m  
Mango porta-electrodos con dos teclas, clavija de 3 patillas y cable de conexión fija de 4 m  
Manche porte-électrode avec interrupteur digital double, fiche à 3 broches et câble de raccordement fixe de 4 m  
Manico portaelettrodi con due tasti, spina a 3-spire e cavo di connessione fisso da 4 m

Ø 4 mm



80-210-18-04 *max. 6300 Vp*

**maXium® e/Erbe ICC/ACC/VIO**

Elektroden-Handgriff mit zwei Tasten, mit 5-mm-Stecker und fest angeschlossenem 4 m Kabel  
Electrode handle with two pushbuttons, with 5-mm plug and permanent cord of 4 m  
Mango porta-electrodos con dos teclas, con clavija de 5 mm y cable de conexión fija de 4 m  
Manche porte-électrode avec interrupteur digital double, avec fiche de 5 mm et câble de raccordement fixe de 4 m  
Manico portaelettrodi con due tasti, con spina da 5 mm e cavo di connessione fisso da 4 m



Ø 4 mm



80-220-02-04 *max. 6300 Vp*

**KLS Martin**

Elektroden-Handgriff ohne Tasten, großem Koax-Stecker und fest angeschlossenem 4 m Kabel  
 Electrode handle without pushbuttons, large coax plug and permanent cord of 4 m  
 Mango porta-electrodos sin teclas, clavija coaxial grande y cable de conexión fija de 4 m  
 Manche porte-électrode sans interrupteur, grande fiche coax et câble de raccordement fixe de 4 m  
 Manico portaelettrodi senza tasti, spina coassiale grande e cavo di connessione fisso da 4 m

Ø 4 mm



80-220-41-04 *max. 6300 Vp*

**maXium® i/ME MB 3 i /Valleylab/Bovie**

Elektroden-Handgriff ohne Tasten, mit 8-mm-Stecker und fest angeschlossenem 4 m Kabel für Valleylab-Geräte  
 Electrode handle without pushbuttons, with 8-mm plug and permanent cord of 4 m, for Valleylab units  
 Mango porta-electrodos sin teclas, con clavija de 8 mm y cable de conexión fija de 4 m para aparatos Valleylab  
 Manche porte-électrode sans interrupteur, avec fiche de 8 mm et câble de raccordement fixe de 4 m pour appareils Valleylab  
 Manico portaelettrodi senza tasti, con spina da 8 mm e cavo di connessione fisso da 4 m per apparecchi Valleylab

Ø 4 mm



80-220-31-04 *max. 6600 Vp*

**maXium® e/Erbe ICC/ACC/VIO**

Elektroden-Handgriff ohne Tasten, mit 5-mm-Stecker und fest angeschlossenem 4 m Kabel  
 Electrode handle without pushbuttons, with 5-mm plug and permanent cord of 4 m  
 Mango porta-electrodos sin teclas, con clavija de 5 mm y cable de conexión fija de 4 m  
 Manche porte-électrode sans interrupteur, avec fiche de 5 mm et câble de raccordement fixe de 4 m  
 Manico portaelettrodi senza tasti, con spina da 5 mm e cavo di connessione fisso da 4 m

Monopolare Elektroden-Handgriffe  
 Monopolar electrode handles  
 Mangos porta-electrodos monopolares  
 Manches porte-électrodes monopolaires  
 Manici portaelettrodi monopolari

smartPen

Passend für **maXium®/maXium® smart C/ME 411/ME 401/ME 400/ME 200**  
 Suitable for **ME MB 3/ME MB 2/ME MB 1/ME M1/ME 102**  
 Para  
 Pour  
 Per

Ø 2,4 mm



80-210-21-04 **max. 6300 Vp**

**KLS Martin/Erbe intern. Version/Valleylab**

Elektroden-Handgriff mit zwei Tasten, 3-Pin-Stecker und fest angeschlossenem 4 m Kabel  
 Electrode handle with two pushbuttons, 3-pin plug and permanent cord of 4 m  
 Mango porta-electrodos con dos teclas, clavija de 3 patillas y cable de conexión fija de 4 m  
 Manche porte-électrode avec interrupteur digital double, fiche à 3 broches et câble de raccordement fixe de 4 m  
 Manico portaelettrodi con due tasti, spina a 3-spire e cavo di connessione fisso da 4 m

Ø 2,4 mm



80-210-23-04 **max. 6300 Vp**

**KLS Martin/Erbe intern. Version/Valleylab**

Elektroden-Handgriff mit Wippschalter, 3-Pin-Stecker und fest angeschlossenem 4 m Kabel  
 Electrode handle with rocker switch, 3-pin plug and permanent cord of 4 m  
 Mango porta-electrodos con interruptor basculante, clavija de 3 patillas y cable de conexión fija de 4 m  
 Manche porte-électrode avec interrupteur à bascule, fiche à 3 broches et câble de raccordement fixe de 4 m  
 Manico portaelettrodi con selettore a levetta, spina a 3-spire e cavo di connessione fisso da 4 m

Ø 4 mm



80-227-00-04 **max. 6300 Vp**

**KLS Martin**

Elektroden-Handgriff mit zwei Tasten, mit abnehmbarem Kabel  
 Electrode handle with two pushbuttons, with detachable cord  
 Mango porta-electrodos con dos teclas, con cable desmontable  
 Manche porte-électrode avec interrupteur digital double, avec câble amovible  
 Manico portaelettrodi con due tasti, con cavo rimovibile



80-227-01-04 **max. 6300 Vp**

**KLS Martin**

Anschlusskabel, 4 m  
 Connection cord, 4 m  
 Cable de conexión, 4 m  
 Câble de raccordement, 4 m  
 Cavo di collegamento, 4 m



80-227-02-04 **max. 6300 Vp**

**Erbe VIO, ICC, ACC**

Anschlusskabel, 4 m  
 Connection cord, 4 m  
 Cable de conexión, 4 m  
 Câble de raccordement, 4 m  
 Cavo di collegamento, 4 m

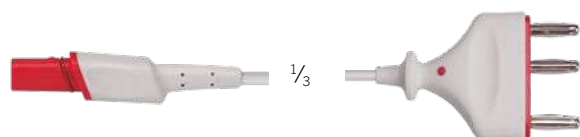

80-227-03-04 **max. 6300 Vp**

**3-Pin**

Anschlusskabel, 4 m  
 Connection cord, 4 m  
 Cable de conexión, 4 m  
 Câble de raccordement, 4 m  
 Cavo di collegamento, 4 m



Passend für MD 62/ME K1/ME K2/ME K3/ME 82/miniCutter

Suitable for  
 Para  
 Pour  
 Per

Ø 4 mm



80-217-05-04 max. 6300 Vp

**KLS Martin**

Elektroden-Handgriff mit einer Taste, großem Koax-Stecker und fest angeschlossenem 4 m Kabel  
 Electrode handle with a pushbutton, large coax plug and permanent cord of 4 m  
 Mango porta-electrodos con una tecla, clavija coaxial grande y cable de conexión fija de 4 m  
 Manche porte-électrode avec un interrupteur digital, grande fiche coax et câble de raccordement fixe de 4 m  
 Manico portaelettrodi con un tasto, spina coassiale grande e cavo di connessione fisso da 4 m

Ø 1,6 mm



80-214-13-04 max. 6300 Vp

**KLS Martin**

Dental-Elektroden-Handgriff mit einer Taste, großem Koax-Stecker und fest angeschlossenem 4 m Kabel  
 Dental electrode handle with a pushbutton, large coax plug and permanent cord of 4 m  
 Mango porta-electrodos dental con una tecla, clavija coaxial grande y cable de conexión fija de 4 m  
 Manche porte-électrode dentaire avec un interrupteur digital, grande fiche coax et câble de raccordement fixe de 4 m  
 Manico portaelettrodi dentale con un tasto, spina coassiale grande e cavo di connessione fisso da 4 m

Ø 1,6 mm



80-214-12-04 max. 6300 Vp

**KLS Martin**

Dental-Elektroden-Handgriff ohne Taste, großem Koax-Stecker und fest angeschlossenem 4 m Kabel  
 Dental electrode handle without pushbutton, large coax plug and permanent cord of 4 m  
 Mango porta-electrodos dental sin tecla, clavija coaxial grande y cable de conexión fija de 4 m  
 Manche porte-électrode dentaire sans interrupteur digital, grande fiche coax et câble de raccordement fixe de 4 m  
 Manico portaelettrodi dentale senza tasto, spina coassiale grande e cavo di connessione fisso da 4 m

Handgriffe · Handles · Mangos · Manches · Manici

	80-217-13-04	80-210-13-04	80-210-18-04	80-217-05-04	80-220-02-04	80-220-41-04	80-220-31-04	80-227-00-04 & 80-227-01-04	80-227-00-04 & 80-227-02-04 & 80-227-03-04	80-227-00-04 & 80-227-03-04
Ø (mm)	4,0	4,0	4,0	4,0	4,0	4,0	4,0	4,0	4,0	4,0
Gerätetyp Type of unit Tipo del aparato Type d'appareil Tipo d'apparecchio										
maXium® m	x	x			x*			x		x
maXium® i		x				x*				x
maXium® e		x	x				x*		x	x
maXium® smart C m	x	x			x*			x		x
maXium® smart C i		x				x*				x
maXium® smart C e		x	x				x*		x	x
ME 411	x	x			x*			x		
ME 401	x	x			x*			x		
ME 400	x	x			x*			x		
ME 200	x	x			x*			x		
ME MB 1	x	x			x*			x		
ME MB 2	x	x			x*			x		
ME MB 3	x	x			x*	x*		x		x
ME 81	x	x			x*			x		
ME 82	x	x		x	x*			x		
miniCutter				x	x*					
ME 102	x	x			x*			x		x
ME 80	x	x			x*			x		
ME 50	x	x			x*			x		
ME K1				x	x*					
ME K2				x	x*					
ME 60				x	x*					
MD 70				x	x*					
MD 62				x	x*					

x\* = bei Verwendung eines Fußschalters  
 for use with foot switch  
 usando un interruptor de pie  
 pour utilisation avec un interrupteur à pédale  
 per l'uso di un interruttore a pedale



	80-210-21-04	80-210-23-04	80-214-13-04	80-214-12-04
Ø (mm)	2,4	2,4	1,6	1,6
Gerätetyp Type of unit Tipo del aparato Type d'appareil Tipo d'apparecchio				
maXium® m	x	x	x	x*
maXium® i	x	x		
maXium® e	x	x		
maXium® smart C m	x	x	x	x*
maXium® smart C i	x	x		
maXium® smart C e	x	x		
ME 411	x	x	x	x*
ME 401	x	x	x	x*
ME 400	x	x	x	x*
ME 200	x	x	x	x*
ME MB 1	x	x	x	x*
ME MB 2	x	x	x	x*
ME MB 3	x	x	x	x*
ME 81	x	x	x	x*
ME 82	x	x	x	x*
miniCutter			x	x*
ME 102	x	x	x	x*
ME 80	x	x	x	x*
ME 50	x	x	x	x*
ME K1				
ME K2				
ME 60			x	x*
MD 70			x	x*
MD 62			x	x*

x\* = bei Verwendung eines Fußschalters  
 for use with foot switch  
 usando un interruptor de pie  
 pour utilisation avec un interrupteur à pédale  
 per l'uso di un interruttore a pedale

Monopolare Elektroden-Handgriffe  
Monopolar electrode handles  
Mangos porta-electrodos monopolares  
Manches porte-électrodes monopolaires  
Manici portaelettrodi monopolari

Passend für **maXium®/maXium® smart C/ME 411/ME 401/ME 400/ME 200**  
Suitable for **ME MB 3/ME MB 2/ME MB 1/ME M1/ME 102**  
Para  
Pour  
Per

Ø 4 mm

1/2



1/3



Ø 12,5 mm

80-220-00-04 *max. 3000 Vp*

**KLS Martin/Aesculap/Berchtold**

Elektroden-Handgriff ohne Tasten, mit großem Koax-Stecker und 4 m Anschlusskabel  
Electrode handle without pushbuttons, with large coax plug and connection cable of 4 m  
Mango porta-electrodos sin teclas con clavija coaxial y cable de conexión de 4 m  
Manche porte-électrode sans interrupteur, avec grande fiche coax et câble de raccordement de 4 m  
Manico portaelettrodi senza tasti, con spina coassiale grande e cavo di connessione da 4 m

Ø 4 mm

1/2



1/3



Ø 12,5 mm

80-217-02-04 *max. 5500 Vp*

**KLS Martin/Aesculap/Berchtold**

Elektroden-Handgriff mit zwei Tasten, großem Koax-Stecker und 4 m Anschlusskabel  
Electrode handle with two pushbuttons, large coax plug and connection cable of 4 m  
Mango porta-electrodos con dos teclas, clavija coaxial grande y cable de conexión de 4 m  
Manche porte-électrode avec interrupteur digital double, grande fiche coax et câble de raccordement de 4 m  
Manico portaelettrodi con due tasti, spina coassiale grande e cavo di connessione da 4 m

80-217-12-04 *max. 5500 Vp*

**KLS Martin/Aesculap/Berchtold**

Elektroden-Handgriff mit zwei Tasten, großem Koax-Stecker und 5 m Anschlusskabel  
Electrode handle with two pushbuttons, large coax plug and connection cable of 5 m  
Mango porta-electrodos con dos teclas, clavija coaxial grande y cable de conexión de 5 m  
Manche porte-électrode avec interrupteur digital double, grande fiche coax et câble de raccordement de 5 m  
Manico portaelettrodi con due tasti, spina coassiale grande e cavo di connessione da 5 m



Passend für **maXium®/maXium® smart C/ME 411/ME 401/ME 400/ME 200**  
Suitable for **ME MB 3/ME MB 2/ME MB 1/ME M1/ME 102**  
Para  
Pour  
Per

1

Ø 4 mm

1/2



80-210-12-04 *max. 5500 V<sub>p</sub>*

**KLS Martin/Erbe intern. Version/Valleylab**

Elektroden-Handgriff mit zwei Tasten, 3-Pin-Stecker und 5 m Anschlusskabel  
Electrode handle with two pushbuttons, 3-pin plug and connection cable of 5 m  
Mango porta-electrodos con dos teclas, clavija de 3 patillas y cable de conexión de 5 m  
Manche porte-électrode avec interrupteur digital double, fiche à 3 broches et câble de raccordement de 5 m  
Manico portaelettrodi con due tasti, spina a 3-spire e cavo di connessione da 5 m

1/3



Ø 4 mm

1/2



Surgi-Pen

80-219-42-04 *max. 4000 V<sub>p</sub>*

**KLS Martin/Erbe intern. Version/Valleylab**

Elektroden-Handgriff mit zwei Tasten, 3-Pin-Stecker und 4 m Anschlusskabel  
Electrode handle with two pushbuttons, 3-pin plug and connection cable of 4 m  
Mango porta-electrodos con dos teclas, clavija de 3 patillas y cable de conexión de 4 m  
Manche porte-électrode avec interrupteur digital double, fiche à 3 broches et câble de raccordement de 4 m  
Manico portaelettrodi con due tasti, spina a 3-spire e cavo di connessione da 4 m

1/3





Monopolare Elektroden-Handgriffe  
Monopolar electrode handles  
Mangos porta-electrodos monopolares  
Manches porte-électrodes monopolaires  
Manici portaelettrodi monopolari

---

Passend für **maXium® e/maXium® smart C**  
Suitable for  
Para  
Pour  
Per



80-220-30-04 *max. 3000 Vp*  
**maXium® e/Erbe ICC/ACC/VIO**

Elektroden-Handgriff ohne Taste, mit 5-mm-Stecker und 4 m Anschlusskabel  
Electrode handle without pushbutton, with 5-mm plug and connection cable of 4 m  
Mango porta-electrodos sin tecla, con clavija de 5 mm y cable de conexión de 4 m  
Manche porte-électrode sans interrupteur, avec fiche de 5 mm et câble de raccordement de 4 m  
Manico portaelettrodi senza tasto, con spina da 5 mm e cavo di connessione da 4 m

---



80-217-32-04 *max. 5500 Vp*  
**maXium® e/Erbe ICC/ACC/VIO**

Elektroden-Handgriff mit zwei Tasten, mit 5-mm-Stecker und 4 m Anschlusskabel  
Electrode handle with two pushbuttons, with 5-mm plug and connection cable of 4 m  
Mango porta-electrodos con dos teclas, clavija de 5 mm y cable de conexión de 4 m  
Manche porte-électrode avec interrupteur digital double, fiche de 5 mm et câble de raccordement de 4 m  
Manico portaelettrodi con due tasti, spina da 5 mm e cavo di connessione da 4 m

---

Passend für **maXium® i, ME MB 3 i, ME MB 2 i**  
Suitable for  
Para  
Pour  
Per



80-220-40-04 *max. 3000 Vp*  
**maXium® i/ME MB 3 i/ME MB 2 i/Valleylab/Bovie**

Elektroden-Handgriff ohne Tasten, mit 8-mm-Stecker und 4 m Anschlusskabel für Valleylab-Geräte  
Electrode handle without pushbuttons, with 8-mm plug and connection cable of 4 m, for Valleylab units  
Mango porta-electrodos sin teclas, con clavija de 8 mm y cable de conexión de 4 m para aparatos Valleylab  
Manche porte-électrode sans interrupteur, avec fiche de 8 mm et câble de raccordement de 4 m pour appareils Valleylab  
Manico portaelettrodi senza tasti, con spina da 8 mm e cavo di connessione da 4 m per apparecchi Valleylab



Passend für **maXium®/maXium® smart C/ME 411/ME 401/ME 400/ME 200**  
 Suitable for **ME MB 3/ME MB 2/ME MB 1/ME M1/ME 102**  
 Para  
 Pour  
 Per



80-221-02-04 **max. 4100 Vp** **STERILE IEO**  
**KLS Martin/Erbe intern. Version/Valleylab**

Einmal-Handgriff mit Lanzette, steril verpackt, 4,2 m Anschlusskabel, VE=10 Stück  
 Disposable handle with lancet, sterile packed, connection cable of 4.2 m, SU=10/pack  
 Mango desechable con lanceta, envase estéril, cable de conexión de 4,2 m, UV=10 piezas  
 Manche à usage unique avec lancette, emballage stérile, câble de raccordement de 4,2 m, UC=10 unités  
 Manico monouso con lancetta, imballaggio sterile, cavo di connessione da 4,2 m, UV=10 pezzi

Passend für Aktivelektroden mit Ø 2,4 mm (siehe Seite 26)  
 For active electrodes Ø 2.4 mm (see page 26)  
 Para electrodos activos con Ø 2,4 mm (véase página 26)  
 Pour électrodes actives Ø 2,4 mm (voir page 26)  
 Per elettrodi attivi con Ø 2,4 mm (vedi a pag. 26)



80-210-16-04 **max. 4000 Vp**  
**KLS Martin/Erbe intern. Version/Valleylab**

Elektroden-Handgriff mit zwei Tasten, 3-Pin-Stecker und 4 m Anschlusskabel  
 Electrode handle with two pushbuttons, 3-pin plug and connection cable of 4 m  
 Mango porta-electrodos con dos teclas, clavija de 3 patillas y cable de conexión de 4 m  
 Manche porte-électrode avec interrupteur digital double, fiche à 3 broches et cable de raccordement de 4 m  
 Manico porta elettrodi con due tasti, spina a 3-spire e cavo di connessione da 4 m



80-210-03-04 **max. 5000 Vp**  
**KLS Martin/Erbe intern. Version/Valleylab**

Elektroden-Handgriff mit zwei Tasten, 3-Pin-Stecker und 4 m Anschlusskabel, 50 Aufbereitungszyklen  
 Electrode handle with two pushbuttons, 3-pin plug and connection cable of 4 m, 50 reprocessing cycles  
 Mango porta-electrodos con dos teclas, clavija de 3 patillas y cable de conexión de 4 m, 50 ciclos de reprocesamiento  
 Manche porte-électrode avec interrupteur digital double, fiche à 3 broches et cable de raccordement de 4 m, 50 cycles de traitement  
 Manico porta elettrodi con due tasti, spina a 3-spire e cavo di connessione da 4 m, 50 cicli di ricondizionamento

Monopolare Elektroden-Handgriffe  
Monopolar electrode handles  
Mangos porta-electrodos monopolares  
Manches porte-électrodes monopolaires  
Manici portaelettrodi monopolari

---

Passend für **MD 62/ME K1/ME K2/ME K3/ME 82/miniCutter**

Suitable for  
Para  
Pour  
Per

Ø 1,6 mm

1/2



1/3



80-214-10-04 *max. 3500 Vp*

**KLS Martin**

Dental-Elektroden-Handgriff ohne Taste, mit großem Koax-Stecker und 3 m Anschlusskabel  
Dental electrode handle without pushbutton, with large coax plug and connection cable of 3 m  
Mango porta-electrodos dental sin tecla, con clavija coaxial grande y cable de conexión de 3 m  
Manche porte-électrode dentaire sans interrupteur digital, avec grande fiche coax et câble de raccordement de 3 m  
Manico portaelettrodi dentale senza tasto, con spina coassiale grande e cavo di connessione da 3 m

---

Ø 1,6 mm

1/2



1/3



80-214-11-04 *max. 2000 Vp*

**KLS Martin**

Dental-Elektroden-Handgriff mit einer Taste, mit großem Koax-Stecker und 3 m Anschlusskabel  
Dental electrode handle with a pushbutton, with large coax plug and connection cable of 3 m  
Mango porta-electrodos dental con una tecla, con clavija coaxial grande y cable de conexión de 3 m  
Manche porte-électrode dentaire avec un interrupteur digital, avec grande fiche coax et câble de raccordement de 3 m  
Manico portaelettrodi dentale con un tasto, con spina coassiale grande e cavo di connessione da 3 m

---

Ø 4 mm

1/2



1/3



80-217-01-04 *max. 5500 Vp*

**KLS Martin**

Elektroden-Handgriff mit einer Taste, großem Koax-Stecker und 4 m Anschlusskabel  
Electrode handle with a pushbutton, large coax plug and connection cable of 4 m  
Mango porta-electrodos con una tecla, clavija coaxial grande y cable de conexión de 4 m  
Manche porte-électrode avec un interrupteur digital, grande fiche coax et câble de raccordement de 4 m  
Manico portaelettrodi con un tasto, spina coassiale grande e cavo di connessione da 4 m



Passend für KLS-Martin-Geräte aus unserem früheren Programm  
 Suitable for KLS Martin units of our former program  
 Para aparatos KLS Martin de nuestra anterior gama de producción  
 Pour appareils KLS Martin de notre ancienne gamme  
 Per apparecchi KLS Martin della nostra gamma precedente

Ø 1,6 mm



80-214-00-04 **max. 3500 Vp**  
**Berchtold**

Dental-Elektroden-Handgriff ohne Taste, mit kleinem Koax-Stecker und 3 m Anschlusskabel  
 Dental electrode handle without pushbutton, with small coax plug and connection cable of 3 m  
 Mango porta-electrodos dental sin tecla, con clavija coaxial pequeña y cable de conexión de 3 m  
 Manche porte-électrode dentaire sans interrupteur digital, avec petite fiche coax et câble de raccordement de 3 m  
 Manico portaelettrodi dentale senza tasto, con spina coassiale piccola e cavo di connessione da 3 m

Ø 1,6 mm



80-214-01-04 **max. 2000 Vp**  
**Berchtold**

Dental-Elektroden-Handgriff mit einer Taste, mit kleinem Koax-Stecker und 3 m Anschlusskabel  
 Dental electrode handle with one pushbutton, small coax plug and connection cable of 3 m  
 Mango porta-electrodos dental con una tecla, con clavija coaxial pequeña y cable de conexión de 3 m  
 Manche porte-électrode dentaire avec un interrupteur digital, avec petite fiche coax et câble de raccordement de 3 m  
 Manico portaelettrodi dentale con un tasto, con spina coassiale piccola e cavo di connessione da 3 m

## NON-CE



80-213-01-04 **max. 750 Vp**

Elektroden-Handgriff für Elektroden Ø 1,6 mm  
 Electrode handle for electrodes Ø 1.6 mm  
 Mango porta-electrodos para electrodos Ø 1,6 mm  
 Manche porte-électrode pour électrodes Ø 1,6 mm  
 Manico portaelettrodi per elettrodi Ø mm 1,6







## NON-CE



80-280-30-04 **max. 4000 Vp**  
 3 m

Anschlusskabel, einpolig,  
 für Griff 80-213-01-04  
 Connection cable, monopolar,  
 for handle 80-213-01-04  
 Cable de conexión, monopolar,  
 para mango 80-213-01-04  
 Câble de raccordement, monopolaire,  
 pour manche 80-213-01-04  
 Cavo di connessione, monopolare,  
 per manico 80-213-01-04

Handgriffe · Handles · Mangos · Manches · Manici



	80-220-00-04	80-217-01-04	80-217-02-04	80-217-12-04	80-219-42-04	80-210-12-04	80-181-02-04
Ø (mm)	4,0	4,0	4,0	4,0	4,0	4,0	4,0
Gerätetyp Type of unit Tipo del aparato Type d'appareil Tipo d'apparecchio							
maXium® m	x*		x	x	x	x	x
maXium® i					x	x	x
maXium® e					x	x	x
maXium® smart C m	x*		x	x	x	x	x
maXium® smart C i						x	x
maXium® smart C e					x	x	x
ME 411	x*		x	x	x	x	x
ME 401	x*		x	x	x	x	x
ME 400	x*		x	x	x	x	x
ME 200	x*		x	x	x	x	x
ME MB 1	x*		x	x	x	x	x
ME MB 2	x*		x	x	x	x	x
ME MB 3	x*		x	x	x	x	
ME 81	x*		x	x	x	x	
ME 82	x*	x				x	
miniCutter		x					
ME 102	x*		x	x	x	x	
ME 80	x*		x	x	x	x	
ME 50	x*		x	x	x	x	
ME K1		x		x			
ME K2		x		x			
ME 60		x		x			
MD 70		x		x			
MD 62		x		x			

x\* = bei Verwendung eines Fußschalters  
 for use with foot switch  
 usando un interruptor de pie  
 pour utilisation avec un interrupteur à pédale  
 per l'uso di un interruttore a pedale



Handgriffe · Handles · Mangos · Manches · Manici

1

	80-221-02-04	80-210-03-04	80-210-16-04	80-214-10-04	80-214-11-04
Ø (mm)	2,4	2,4	2,4	1,6	1,6
Gerätetyp Type of unit Tipo del aparato Type d'appareil Tipo d'apparecchio					
maXium® m	x	x	x	x*	
maXium® i	x	x	x	x*	
maXium® e	x	x	x	x*	
maXium® smart C m	x	x	x	x*	
maXium® smart C i	x	x	x	x*	
maXium® smart C e	x	x	x	x*	
ME 411	x	x	x	x*	
ME 401	x	x	x	x*	
ME 400	x	x	x	x*	
ME 200	x	x	x	x*	
ME MB 1	x	x	x	x*	
ME MB 2	x	x	x	x*	
ME MB 3	x	x	x	x*	
ME 81	x	x	x	x*	
ME 82	x	x	x	x*	x
miniCutter				x*	x
ME 102	x	x	x	x*	
ME 80	x	x	x		
ME 50	x	x	x		
ME K1				x*	x
ME K2				x*	x
ME 60				x*	x
MD 70				x*	x
MD 62				x*	x

x\* = bei Verwendung eines Fußschalters  
 for use with foot switch  
 usando un interruptor de pie  
 pour utilisation avec un interrupteur à pédale  
 per l'uso di un interruttore a pedale

Monopolare Elektroden  
Monopolar electrodes  
Electrodos monopolares  
Electrodes monopolaires  
Elettrodi monopolari

# 2



Monopolare Elektroden  
 Monopolar electrodes  
 Electrodo monopolares  
 Electrodes monopolaires  
 Elettrodi monopolari

**KLS-Martin-SYN-Elektroden mit Kunststoffisolation**  
**KLS Martin SYN electrodes with plastic insulation**  
**SYN electrodo KLS Martin con aislamiento de plástico**  
**SYN électrodes KLS Martin avec isolation en matière plastique**  
**SYN elettrodi KLS Martin con isolamento in materiale plastico**

**Aktivelektroden mit Ø 4 mm**  
**Active electrodes Ø 4 mm**  
**Electrodo activos con Ø 4 mm**  
**Electrodes actives Ø 4 mm**  
**Elettrodi attivi Ø 4 mm**

Ø 4 mm  **max. 4000 V<sub>p</sub>**



80-510-06-04

Lanzettelektrode, gerade, VE = 5 Stück  
 Lancet electrode, straight, SU = 5/pack  
 Electrodo de lanceta, recto, UV = 5 piezas  
 Electrode lancette, droite, UC = 5 unités  
 Elettrodo a lancetta, retto, UV = 5 pezzi



80-511-06-04

Lanzettelektrode, abgewinkelt, isoliert  
 Lancet electrode, angled, insulated  
 Electrodo de lanceta, acodado, aislado  
 Electrode lancette, coudée, isolée  
 Elettrodo a lancetta, angolato, isolato

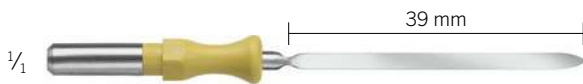

80-515-06-04

Messerelektrode, VE = 5 Stück  
 Knife electrode, SU = 5/pack  
 Electrodo de cuchillo, UV = 5 piezas  
 Electrode couteau, UC = 5 unités  
 Elettrodo a bisturi, UV = 5 pezzi

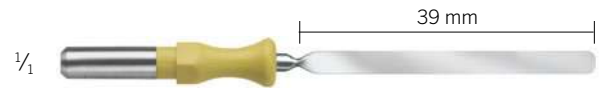

80-516-06-04

Mammaria-Spatel  
 Mammary spatula (electrode)  
 Electrodo de mammaria  
 Electrode spatule  
 Elettrodo a mammaria



80-520-06-04

Nadelelektrode, VE = 5 Stück  
 Needle electrode, SU = 5/pack  
 Electrodo de aguja, UV = 5 piezas  
 Electrode aiguille, UC = 5 unités  
 Elettrodo ad ago, UV = 5 pezzi



80-521-04-04

Nadelelektrode isoliert  
 Needle electrode insulated  
 Electrodo de aguja aislado  
 Electrode aiguille isolée  
 Elettrodo ad ago isolato



80-521-02-04

Nadelelektrode, VE = 5 Stück  
 Needle electrode, SU = 5/pack  
 Electrodo de aguja, UV = 5 piezas  
 Electrode aiguille, UC = 5 unités  
 Elettrodo ad ago, UV = 5 pezzi



80-522-04-04

Nadelelektrode isoliert  
 Needle electrode insulated  
 Electrodo de aguja aislado  
 Electrode aiguille isolée  
 Elettrodo ad ago isolato





**Aktivelektroden mit Ø 4 mm**  
**Active electrodes Ø 4 mm**  
**Electrodo activos con Ø 4 mm**  
**Electrodes actives Ø 4 mm**  
**Elettrodi attivi Ø 4 mm**

max. 4000 V<sub>p</sub>



80-542-06-04

Drahtschlingenelektrode, Wolfram  
 Wire loop electrode, tungsten  
 Electrodo de asa de alambre, tungsteno  
 Electrode anse en fil, en tungstène  
 Elettrodo ad ansa di filo, tungsteno



80-550-06-04

Bandschlingenelektrode  
 Ribbon loop electrode  
 Electrodo de asa de cinta  
 Electrode boucle  
 Elettrodo ad ansa a nastro



80-560-06-04

Kugelelektrode,	VE = 5 Stück
Ball electrode,	SU = 5/pack
Electrodo de bola,	UV = 5 piezas
Electrode boule,	UC = 5 unités
Elettrodo a sfera,	UV = 5 pezzi



80-562-06-04

Kugelelektrode,	VE = 5 Stück
Ball electrode,	SU = 5/pack
Electrodo de bola,	UV = 5 piezas
Electrode boule,	UC = 5 unités
Elettrodo a sfera,	UV = 5 pezzi



80-580-06-04

Elektroden-Satz, bestehend aus:	1 x 80-510-06-04
Electrode set, consisting of:	1 x 80-515-06-04
Set electrodos, compuesto de:	1 x 80-520-06-04
Set électrodes, composé de:	1 x 80-560-06-04
Set elettrodi, composto da:	1 x 80-562-06-04

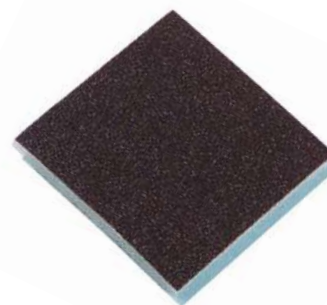

80-505-00-04 **STERILE EO**

Reinigungspad für Elektroden, steril verpackt,	VE = 100 Stück
Cleaning pad for electrodes, sterile packed,	SU = 100 /pack
Almohadilla de limpieza para electrodos, embalado estéril,	UV = 100 piezas
Tampon de nettoyage pour électrodes, emballage stérile,	UC = 100 unités
Tampone di pulizia per elettrodi, imballaggio sterile,	UV = 100 pezzi

Monopolare Elektroden  
 Monopolar electrodes  
 Electrodo monopolar  
 Electrodes monopolaires  
 Elettrodi monopolari

**KLS-Martin-SYN-Elektroden mit Kunststoffisolation**  
**KLS Martin SYN electrodes with plastic insulation**  
**SYN electrodos KLS Martin con aislamiento de plástico**  
**SYN électrodes KLS Martin avec isolation en matière plastique**  
**SYN elettrodi KLS Martin con isolamento in materiale plastico**

**Aktivelektroden mit Ø 2,4 mm**  
**Active electrodes Ø 2.4 mm**  
**Electrodos activos con Ø 2,4 mm**  
**Electrodes actives Ø 2,4 mm**  
**Elettrodi attivi Ø 2,4 mm**

Ø 2,4 mm 



80-520-09-04 **max. 2900 Vp**  
 Nadelektrode für die Mikrodisektion, Wolframspitze,  
 VE = 5 Stück, wiederverwendbar  
 Needle electrode for dissection, tungsten tip,  
 5 items/pack, reusable  
 Electrodo de aguja para la disección, punta de tungsteno,  
 UE = 5 unidades, reutilizable  
 Electrode aiguille pour dissection, pointe en tungstène,  
 UE = 5 pièces, réutilisable  
 Elettrodo ad ago per dissezione, punta in tungsteno,  
 UV = 5 unità, riutilizzabile



80-520-10-04 **max. 2900 Vp** **STERILE!**  
 Nadelektrode für die Mikrodisektion, Wolframspitze,  
 VE = 5 Stück, steril verpackt, zum Einmalgebrauch  
 Needle electrode for dissection, tungsten tip,  
 5 items/pack, sterile packed, single-use  
 Electrodo de aguja para la disección, punta de tungsteno,  
 UE = 5 unidades, embalado estéril, de un solo uso  
 Electrode aiguille pour dissection, pointe en tungstène,  
 UE = 5 pièces, emballage stérile, à usage unique  
 Elettrodo ad ago per dissezione, punta in tungsteno,  
 UV = 5 unità, imballaggio sterile, monouso



80-510-08-04 **max. 3250 Vp**  
 Lanzettelektrode, gerade  
 Lancet electrode, straight  
 Electrodo de lanceta, recto  
 Electrode lancette, droite  
 Elettrodo a lancetta, retto



80-515-08-04 **max. 3250 Vp**  
 Messerelektrode  
 Knife electrode  
 Electrodo de cuchillo  
 Electrode couteau  
 Elettrodo a bisturi



80-520-08-04 **max. 3250 Vp**  
 Nadelektrode  
 Needle electrode  
 Electrodo de aguja  
 Electrode aiguille  
 Elettrodo ad ago



80-542-08-04 **max. 3250 Vp**  
 Drahtschlingenelektrode, Wolfram  
 Wire loop electrode, tungsten  
 Electrodo de asa de alambre, tungsteno  
 Electrode anse en fil, en tungstène  
 Elettrodo ad ansa di filo, tungsteno



80-562-08-04 **max. 3250 Vp**  
 Kugelelektrode  
 Ball electrode  
 Electrodo de bola  
 Electrode boule  
 Elettrodo a sfera



**KLS-Martin-Edelstahlelektroden**  
**KLS Martin stainless steel electrodes**  
**Electrodos KLS Martin de acero inoxidable**  
**Electrodes KLS Martin en acier inoxydable**  
**Elettrodi KLS Martin in acciaio inox**

**Aktivelektroden mit Ø 4 mm**  
**Active electrodes Ø 4 mm**  
**Electrodos activos con Ø 4 mm**  
**Electrodes actives Ø 4 mm**  
**Elettrodi attivi Ø 4 mm**



80-510-04-04  
 Lanzettelektrode, gerade  
 Lancet electrode, straight  
 Electrodo de lanceta, recto  
 Electrode lancette, droite  
 Elettrodo a lancetta, retto



80-511-04-04  
 Lanzettelektrode, abgewinkelt  
 Lancet electrode, angled  
 Electrodo de lanceta, acodado  
 Electrode lancette, coudée  
 Elettrodo a lancetta, angolato



80-540-04-04 = Ø 5 mm  
 80-542-04-04 = Ø 10 mm  
 80-545-04-04 = Ø 20 mm  
 Drahtschlingenelektrode  
 Wire loop electrode  
 Electrodo de asa de alambre  
 Electrode anse en fil  
 Elettrodo ad ansa di filo



80-515-04-04  
 Messerelektrode  
 Knife electrode  
 Electrodo de cuchillo  
 Electrode couteau  
 Elettrodo a bisturi



80-550-04-04 = Ø 10 mm  
 80-552-04-04 = Ø 15 mm  
 Bandschlingenelektrode  
 Ribbon loop electrode  
 Electrodo de asa de cinta  
 Electrode boucle  
 Elettrodo ad ansa a nastro



80-516-04-04  
 Mammaria-Spatel  
 Mammary spatula (electrode)  
 Electrodo de mammaria  
 Electrode spatule  
 Elettrodo a mammaria



80-519-04-04  
 Nadelelektrode  
 Needle electrode  
 Electrodo de aguja  
 Electrode aiguille  
 Elettrodo ad ago



80-520-04-04  
 Nadelelektrode  
 Needle electrode  
 Electrodo de aguja  
 Electrode aiguille  
 Elettrodo ad ago



80-570-04-04 = 8 x 10 mm  
 80-572-04-04 = 10 x 10 mm  
 80-574-04-04 = 12 x 10 mm  
 Plattenelektrode  
 Plate electrode  
 Electrodo de placa  
 Electrode plaque  
 Elettrodo a piastr



80-560-04-04 = Ø 2 mm  
 80-562-04-04 = Ø 4 mm  
 80-563-04-04 = Ø 5 mm  
 Kugelelektrode  
 Ball electrode  
 Electrodo de bola  
 Electrode boule  
 Elettrodo a sfera

Monopolare Elektroden  
Monopolar electrodes  
Electrodos monopolares  
Electrodes monopolaires  
Elettrodi monopolari

**Aktivelektroden mit Ø 4 mm**  
**Active electrodes Ø 4 mm**  
**Electrodos activos con Ø 4 mm**  
**Electrodes actives Ø 4 mm**  
**Elettrodi attivi Ø 4 mm**

**Wolfram**  
**Tungsten**  
**Tungsteno**  
**En tungstène**  
**Tungsteno**



*max. 650 V<sub>p</sub>*



80-680-12-04

Konisationselektrode  
Conization electrode  
Electrodo para conización  
Electrode pour l'électroconisation  
Elettrodo per conizzazione



80-681-12-04

Konisationselektrode  
Conization electrode  
Electrodo para conización  
Electrode pour l'électroconisation  
Elettrodo per conizzazione

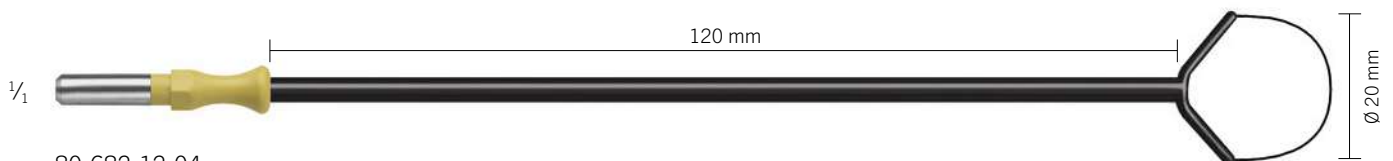

80-682-12-04

Konisationselektrode  
Conization electrode  
Electrodo para conización  
Electrode pour l'électroconisation  
Elettrodo per conizzazione

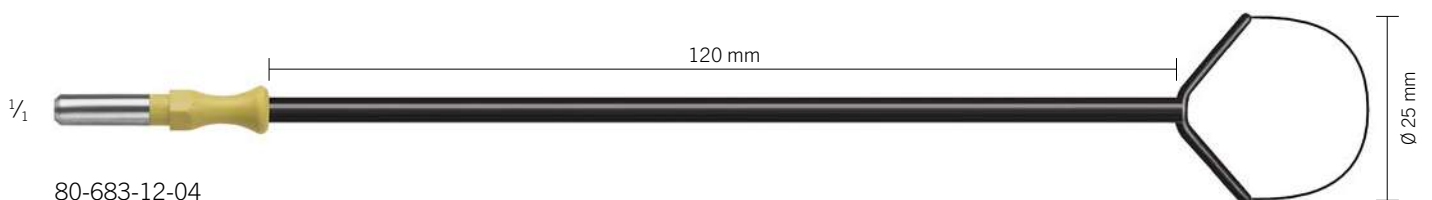

80-683-12-04

Konisationselektrode  
Conization electrode  
Electrodo para conización  
Electrode pour l'électroconisation  
Elettrodo per conizzazione



**Aktivelektroden mit Ø 4 mm**  
**Active electrodes Ø 4 mm**  
**Electrodoos activos con Ø 4 mm**  
**Electrodes actives Ø 4 mm**  
**Elettrodi attivi Ø 4 mm**

**Wolfram**  
**Tungsten**  
**Tungsteno**  
**En tungstène**  
**Tungsteno**

Weitere Informationen entnehmen Sie bitte der separaten Broschüre.

For further information please refer to our separate product brochure.

Encontrará informaciones adicionales en el folleto individual.

Vous trouverez des informations supplémentaires dans la brochure.

Per ulteriori informazioni vedasi il prospetto separato.

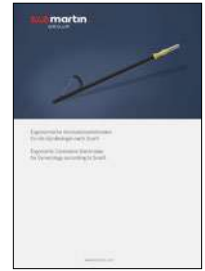

2

Ø 4 mm

max. 650 V<sub>p</sub>

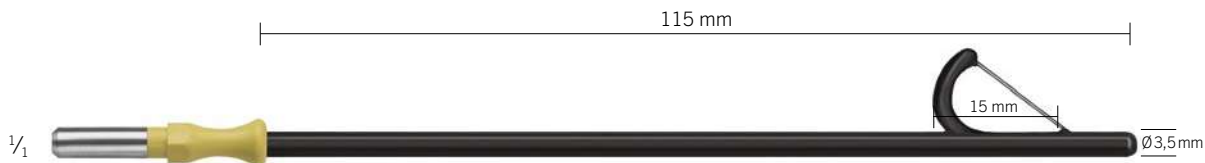

80-684-12-04

Konisationselektrode nach Scarfi  
 Conization electrode  
 Electrodo para conización  
 Electrode pour l'électroconisation  
 Elettrodo per conizzazione



80-685-12-04

Konisationselektrode nach Scarfi  
 Conization electrode  
 Electrodo para conización  
 Electrode pour l'électroconisation  
 Elettrodo per conizzazione

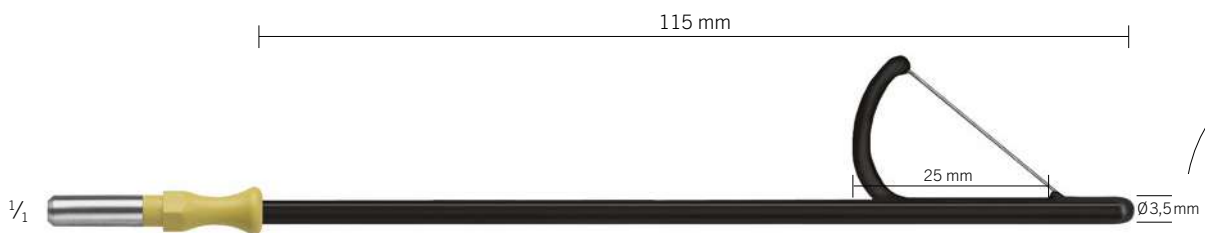

80-686-12-04

Konisationselektrode nach Scarfi  
 Conization electrode  
 Electrodo para conización  
 Electrode pour l'électroconisation  
 Elettrodo per conizzazione

Monopolare Elektroden  
Monopolar electrodes  
Electrodos monopolares  
Electrodes monopolaires  
Elettrodi monopolari

---

**Aktivelektroden mit Ø 4 mm**  
**Active electrodes Ø 4 mm**  
**Electrodos activos con Ø 4 mm**  
**Electrodes actives Ø 4 mm**  
**Elettrodi attivi Ø 4 mm**

Ø 4 mm 



80-675-13-04 **max. 3500 Vp**

Nadelelektrode, isoliert  
Needle electrode, insulated  
Electrodo de aguja, aislado  
Electrode aiguille, isolée  
Elettrodo ad ago, isolato

---



80-677-12-04 **max. 3500 Vp**

Nadelelektrode, isoliert  
Needle electrode, insulated  
Electrodo de aguja, aislado  
Electrode aiguille, isolée  
Elettrodo ad ago, isolato

---

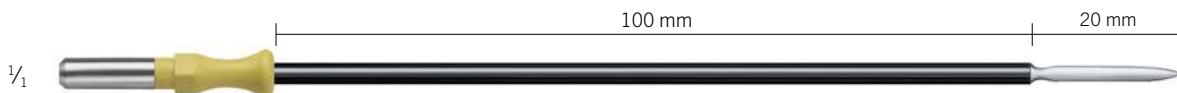

80-510-12-04 **max. 4000 Vp**

Lanzettelektrode, isoliert  
Lancet electrode, insulated  
Electrodo de lanceta, aislado  
Electrode lancette, isolée  
Elettrodo a lancetta, isolato

---

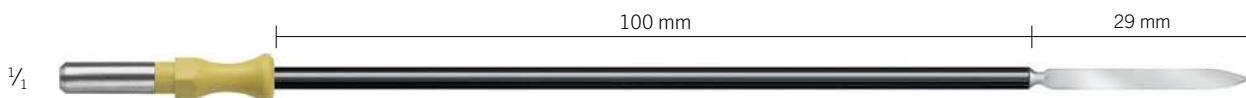

80-515-12-04 **max. 4000 Vp**

Messerelektrode, isoliert  
Knife electrode, insulated  
Electrodo de cuchillo, aislado  
Electrode couteau, isolée  
Elettrodo a bisturi, isolato



**Aktivelektroden mit Ø 4 mm**  
**Active electrodes Ø 4 mm**  
**Electrodoos activos con Ø 4 mm**  
**Electrodes actives Ø 4 mm**  
**Elettrodi attivi Ø 4 mm**

Ø 4 mm  *max. 4000 V<sub>p</sub>*



80-515-14-04  
 Messerelektrode, kurz, isoliert  
 Knife electrode, short, insulated  
 Electrodo de cuchillo, corto, aislado  
 Electrode couteau, courte, isolée  
 Elettrodo a bisturi, corto, isolato

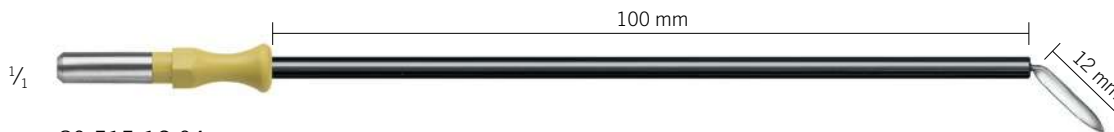

80-515-16-04  
 Messerelektrode, kurz, abgewinkelt, isoliert  
 Knife electrode, short, angled, insulated  
 Electrodo de cuchillo, corto, acodado, aislado  
 Electrode couteau, courte, coudée, isolée  
 Elettrodo a bisturi, corto, angolato, isolato

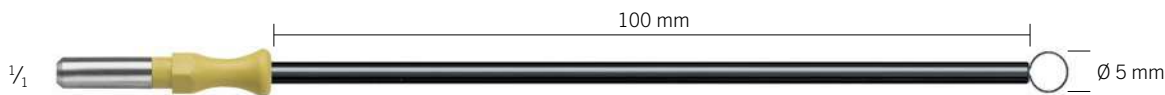

80-540-12-04  
 Drahtschlingenelektrode, isoliert, Wolfram  
 Wire loop electrode, insulated, tungsten  
 Electrodo de asa de alambre, aislado, tungsteno  
 Electrode anse en fil, isolée, en tungstène  
 Elettrodo ad ansa di filo, isolato, tungsteno

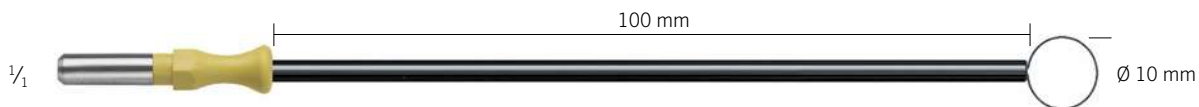

80-542-12-04  
 Drahtschlingenelektrode, isoliert, Wolfram  
 Wire loop electrode, insulated, tungsten  
 Electrodo de asa de alambre, aislado, tungsteno  
 Electrode anse en fil, isolée, en tungstène  
 Elettrodo ad ansa di filo, isolato, tungsteno

Monopolare Elektroden  
 Monopolar electrodes  
 Electrodo monopolar  
 Electrodes monopolaires  
 Elettrodi monopolari

**Aktivelektroden mit Ø 4 mm**  
**Active electrodes Ø 4 mm**  
**Electrodo activos con Ø 4 mm**  
**Electrodes actives Ø 4 mm**  
**Elettrodi attivi Ø 4 mm**



80-674-12-04 **max. 4000 Vp**  
 Kugelelektrode, isoliert  
 Ball electrode, insulated  
 Electrodo de bola, aislado  
 Electrode boule, isolée  
 Elettrodo a sfera, isolato

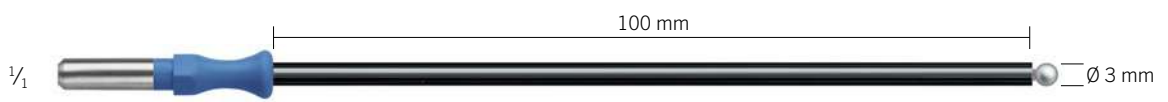

80-674-13-04 **max. 4000 Vp**  
 Kugelelektrode, isoliert  
 Ball electrode, insulated  
 Electrodo de bola, aislado  
 Electrode boule, isolée  
 Elettrodo a sfera, isolato



80-676-13-04 **max. 3500 Vp**  
 Kugelelektrode, isoliert  
 Ball electrode, insulated  
 Electrodo de bola, aislado  
 Electrode boule, isolée  
 Elettrodo a sfera, isolato



80-534-06-04 **max. 2000 Vp**  
 Elektroden-Verlängerung, isoliert, biegsam, Ø 4 mm/Ø 4 mm  
 Electrode extension, insulated, flexible, Ø 4 mm/Ø 4 mm  
 Extensión de electrodo, aislada, flexible, Ø 4 mm/Ø 4 mm  
 Prolongation d'électrode, isolée, flexible, Ø 4 mm/Ø 4 mm  
 Prolunga per elettrodo, isolata, flessibile, Ø 4 mm/Ø 4 mm



80-534-12-04 **max. 2000 Vp**  
 Elektroden-Verlängerung, isoliert, biegsam, Ø 4 mm/Ø 4 mm  
 Electrode extension, insulated, flexible, Ø 4 mm/Ø 4 mm  
 Extensión de electrodo, aislada, flexible, Ø 4 mm/Ø 4 mm  
 Prolongation d'électrode, isolée, flexible, Ø 4 mm/Ø 4 mm  
 Prolunga per elettrodo, isolata, flessibile, Ø 4 mm/Ø 4 mm





**Aktivelektroden mit Ø 2,4 mm**  
**Active electrodes Ø 2.4 mm**  
**Electrodoos activos con Ø 2,4 mm**  
**Electrodes actives Ø 2,4 mm**  
**Elettrodi attivi Ø 2,4 mm**

Ø 2,4 mm 



80-678-10-04 **max. 3250 Vp**

Messerelektrode, isoliert  
 Knife electrode, insulated  
 Electrodo de cuchillo, aislado  
 Electrode couteau, isolée  
 Elettrodo a bisturi, isolato



80-678-11-04 **max. 3250 Vp**

Kugelelektrode, isoliert  
 Ball electrode, insulated  
 Electrodo de bola, aislado  
 Electrode boule, isolée  
 Elettrodo a sfera, isolato



80-678-05-04 **max. 2000 Vp**

Elektroden-Verlängerung, Ø 2,4 mm / Ø 2,4 mm, Länge = 14 cm  
 Electrode extension, Ø 2.4 mm / Ø 2.4 mm, length = 14 cm  
 Extensión de electrodo, Ø 2,4 mm / Ø 2,4 mm, longitud = 14 cm  
 Rallonge d'électrode, Ø 2,4 mm / Ø 2,4 mm, longueur = 14 cm  
 Prolunga per elettrodo, Ø 2,4 mm / Ø 2,4 mm, lunghezza = 14 cm

Monopolare Elektroden für die HNO  
Monopolar electrodes for ENT  
Electrodos monopolares para la otorrinolaringología  
Electrodes monopolaires pour l'O.R.L.  
Elettrodi monopolari per l'otorinolaringoiatria

---

**Aktivelektroden mit Ø 4 mm**  
**Active electrodes Ø 4 mm**  
**Electrodos activos con Ø 4 mm**  
**Electrodes actives Ø 4 mm**  
**Elettrodi attivi Ø 4 mm**

Ø 4 mm 





**Aktivelektroden mit Ø 4 mm**  
**Active electrodes Ø 4 mm**  
**Electrodos activos con Ø 4 mm**  
**Electrodes actives Ø 4 mm**  
**Elettrodi attivi Ø 4 mm**

Ø 4 mm  **max. 5500 V<sub>p</sub>**



80-690-12-04  
 Nadelelektrode, isoliert, 90° abgewinkelt  
 Needle electrode, insulated, 90° angled  
 Electrodo de aguja, aislado, acodado 90°  
 Electrode aiguille, isolée, coudée 90°  
 Elettrodo ad ago, isolato, angolo 90°



80-691-12-04  
 Nadelelektrode, isoliert, 90° abgewinkelt  
 Needle electrode, insulated, 90° angled  
 Electrodo de aguja, aislado, acodado 90°  
 Electrode aiguille, isolée, coudée 90°  
 Elettrodo ad ago, isolato, angolo 90°



80-692-12-04  
 Nadelelektrode, isoliert, 45° abgewinkelt  
 Needle electrode, insulated, 45° angled  
 Electrodo de aguja, aislado, acodado 45°  
 Electrode aiguille, isolée, coudée 45°  
 Elettrodo ad ago, isolato, angolo 45°



80-693-12-04  
 Messerelektrode, isoliert, 45° abgewinkelt  
 Knife electrode, insulated, 45° angled  
 Electrodo de cuchillo, aislado, acodado 45°  
 Electrode couteau, isolée, coudée 45°  
 Elettrodo a bisturi, isolato, angolo 45°



80-694-12-04  
 Tastelektrode, isoliert, 90° abgewinkelt  
 Probe electrode, insulated, 90° angled  
 Electrodo de sondeo, aislado, acodado 90°  
 Electrode sonde, isolée, coudée 90°  
 Elettrodo sensore, isolato, angolo 90°



80-695-12-04  
 Kugelelektrode  
 Ball electrode  
 Electrodo de bola  
 Electrode boule  
 Elettrodo a sfera

**Elektroden mit Ø 1,6 mm**  
**Electrodes Ø 1.6 mm**  
**Electrodo con Ø 1,6 mm**  
**Electrodes Ø 1,6 mm**  
**Elettrodi Ø 1,6 mm**

Ø 1,6 mm  **max. 500 V<sub>p</sub>**



80-461-01-04

Fig. 1

Nadelelektrode, gerade  
 Needle electrode, straight  
 Electrodo de aguja, recto  
 Electrode aiguille, droite  
 Elettrodo ad ago, retto



80-462-01-04

Fig. 1

Nadelelektrode, kurz, gerade  
 Needle electrode, short, straight  
 Electrodo de aguja, corto, recto  
 Electrode aiguille, courte, droite  
 Elettrodo ad ago, corto, retto



80-466-01-04

Fig. 1

Nadelelektrode, gerade  
 Needle electrode, straight  
 Electrodo de aguja, recto  
 Electrode aiguille, droite  
 Elettrodo ad ago, retto



80-463-01-04

Fig. 1

Nadelelektrode, gerade  
 Needle electrode, straight  
 Electrodo de aguja, recto  
 Electrode aiguille, droite  
 Elettrodo ad ago, retto



80-461-02-04

Fig. 2

Nadelelektrode, 45° abgewinkelt  
 Needle electrode, 45° angled  
 Electrodo de aguja, acodado 45°  
 Electrode aiguille, coudée en 45°  
 Elettrodo ad ago, angolo 45°



80-462-02-04

Fig. 2

Nadelelektrode, 45° abgewinkelt  
 Needle electrode, 45° angled  
 Electrodo de aguja, acodado 45°  
 Electrode aiguille, coudée en 45°  
 Elettrodo ad ago, angolo 45°



80-464-02-04

Fig. 2

Nadelelektrode, 45° abgewinkelt, **mit ausziehbarem und kürzbarem Draht**  
 Needle electrode, 45° angled, **with extendable wire that can be cut as well**  
 Electrodo de aguja, acodado 45°, **con alambre extensible que también puede acortarse**  
 Electrode aiguille, coudée 45°, **avec fil extensible et raccourcissable**  
 Elettrodo ad ago, angolo 45°, **con filo metallico estraibile ed accorciabile**



80-461-03-04

Fig. 3

Nadelelektrode, 120° abgewinkelt  
 Needle electrode, 120° angled  
 Electrodo de aguja, acodado 120°  
 Electrode aiguille, coudée en 120°  
 Elettrodo ad ago, angolo 120°



**Elektroden mit Ø 1,6 mm**      **Drahtstärke der Drahtschlingenelektroden = Ø 0,2 mm**  
**Electrodes Ø 1.6 mm**      **Wire size of wire loop electrodes = Ø 0.2 mm**  
**Electrodo con Ø 1,6 mm**      **Grosor del alambre del electrodo de asa = Ø 0,2 mm**  
**Electrodes Ø 1,6 mm**      **Epaisseur du fil des électrodes anse = Ø 0,2 mm**  
**Elettrodi Ø 1,6 mm**      **Spessore filo degli elettrodi ad ansa = Ø 0,2 mm**

Ø 1,6 mm max. 500 V<sub>p</sub>



80-464-38-04

Fig. 2

Nadelelektrode, 45° abgewinkelt,  
**verlängerte Isolation, mit ausziehbarem und kürzbarem Draht**  
 Needle electrode, 45° angled  
**extended insulation, with extendable wire that can be cut as well**  
 Electrodo de aguja, acodado 45°  
**aislamiento prolongado, con alambre extensible que también puede acortarse**  
 Electrode aiguille, coudée 45°  
**isolation rallongée, avec fil extensible et raccourcissable**  
 Elettrodo ad ago, angolo 45°  
**isolamento prolungato, con filo metallico estraibile ed accorciabile**



80-461-04-04

Nadelelektroden nach Dr. Haus, links und rechts, 1 Paar  
 Needle electrodes acc. to Dr. Haus, left and right, 1 pair  
 Electrodo de aguja según Dr. Haus, izquierdo y derecho, un par  
 Electrodes aiguille selon Dr. Haus, gauche et droite, 1 paire  
 Elettrodi ad ago secondo Dr. Haus, sinistro e destro, 1 paio



80-461-06-04

Fig. 6

Drahtschlingenelektrode, Schaft 45° abgewinkelt  
 Wire loop electrode, shaft 45° angled  
 Electrodo de asa de alambre, vástago acodado 45°  
 Electrode anse, tige coudée en 45°  
 Elettrodo ad ansa, asta curva a 45°



80-461-07-04

Scheibenelektrode, Schaft 45° abgewinkelt  
 Disk electrode, shaft 45° angled  
 Electrodo de disco, vástago acodado 45°  
 Electrode discoïdale, tige coudée en 45°  
 Elettrodo a disco, asta curva a 45°



80-461-11-04

Fig. 11

Drahtschlingenelektrode  
 Wire loop electrode  
 Electrodo de asa de alambre  
 Electrode anse  
 Elettrodo ad ansa



80-462-11-04

Fig. 11

Drahtschlingenelektrode  
 Wire loop electrode  
 Electrodo de asa de alambre  
 Electrode anse  
 Elettrodo ad ansa



80-461-12-04

Fig. 12

Drahtschlingenelektrode  
 Wire loop electrode  
 Electrodo de asa de alambre  
 Electrode anse  
 Elettrodo ad ansa



80-462-12-04

Fig. 12

Drahtschlingenelektrode  
 Wire loop electrode  
 Electrodo de asa de alambre  
 Electrode anse  
 Elettrodo ad ansa



80-461-13-04

Fig. 13

Drahtschlingenelektrode  
 Wire loop electrode  
 Electrodo de asa de alambre  
 Electrode anse  
 Elettrodo ad ansa



80-462-13-04

Fig. 13

Drahtschlingenelektrode  
 Wire loop electrode  
 Electrodo de asa de alambre  
 Electrode anse  
 Elettrodo ad ansa

<b>Elektroden mit Ø 1,6 mm</b>	<b>Drahtstärke der Drahtschlingenelektroden = Ø 0,2 mm</b>
<b>Electrodes Ø 1.6 mm</b>	<b>Wire size of wire loop electrodes = Ø 0.2 mm</b>
<b>Electrodoes con Ø 1,6 mm</b>	<b>Grosor del alambre del electrodo de asa = Ø 0,2 mm</b>
<b>Electrodes Ø 1,6 mm</b>	<b>Epaisseur du fil des électrodes anse = Ø 0,2 mm</b>
<b>Elettrodi Ø 1,6 mm</b>	<b>Spessore filo degli elettrodi ad ansa = Ø 0,2 mm</b>

Ø 1,6 mm  *max. 500 V<sub>p</sub>*



80-461-14-04

Fig. 14

8,0 x 5,0 mm

Drahtschlingenelektrode, rhombusförmig  
 Wire loop electrode, rhombic  
 Electrodo de asa de alambre romboidal  
 Electrode anse, romboïdale  
 Elettrodo ad ansa a forma di rombo



80-461-15-04

Fig. 15

7,0 x 1,5 mm

Drahtschlingenelektrode, länglich, Schaft 45° abgewinkelt  
 Wire loop electrode, elongated, shaft 45° angled  
 Electrodo de asa de alambre oblonga, vástago acodado 45°  
 Electrode anse, forme allongée, tige coudée en 45°  
 Elettrodo ad ansa retta, asta curva a 45°



80-461-16-04

Fig. 16

7 mm

Hakenelektrode, 45° abgewinkelt  
 Hook electrode, 45° angled  
 Electrodo de gancho, vástago acodado 45°  
 Electrode crochet, tige coudée 45°  
 Elettrodo ad uncino, 7 mm, asta curva a 45°



80-461-17-04

Fig. 17

6,0 x 1,3 mm

Drahtschlingenelektrode, länglich, gerade  
 Wire loop electrode, elongated, straight  
 Electrodo de asa de alambre oblonga, recto  
 Electrode anse, forme allongée, droite  
 Elettrodo ad ansa retta



80-461-18-04

Fig. 18

7,0 x 1,7 mm

Drahtschlingenelektrode, länglich, 30° abgewinkelt  
 Wire loop electrode, elongated, 30° angled  
 Electrodo de asa de alambre oblonga, acodado 30°  
 Electrode anse, forme allongée, coudée en 30°  
 Elettrodo ad ansa curva, angolo 30°



80-461-19-04

Fig. 19

5,5 x 1,4 mm

Drahtschlingenelektrode, länglich, 90° abgewinkelt  
 Wire loop electrode, elongated, 90° angled  
 Electrodo de asa de alambre oblonga, acodado 90°  
 Electrode anse, forme allongée, coudée en 90°  
 Elettrodo ad ansa curva, angolo 90°



80-461-20-04

Fig. 20

7,0 x 1,4 mm

Drahtschlingenelektrode, länglich, 45° abgewinkelt  
 Wire loop electrode, elongated, 45° angled  
 Electrodo de asa de alambre oblonga, acodado 45°  
 Electrode anse, forme allongée, coudée en 45°  
 Elettrodo ad ansa curva, angolo 45°



80-461-21-04

Fig. 21

7,0 x 1,3 mm

Drahtschlingenelektrode, länglich, gerade  
 Wire loop electrode, elongated, straight  
 Electrodo de asa de alambre oblonga, recto  
 Electrode anse, forme allongée, droite  
 Elettrodo ad ansa retta



**Elektroden mit Ø 1,6 mm**  
**Electrodes Ø 1.6 mm**  
**Electrodoos con Ø 1,6 mm**  
**Electrodes Ø 1,6 mm**  
**Elettrodi Ø 1,6 mm**

Ø 1,6 mm  **max. 500 V<sub>p</sub>**



80-461-23-04  
 Implantationselektrode, 45° abgewinkelt,  
 Implantatology electrode, 45° angled  
 Electrodo per implantologia, acodado 45  
 Electrode pour implantologie, coudée en 45°  
 Elettrodo per implantologia, angolo 45°



80-461-22-04  
 Fig. 22  
 13,0 x 1,0 mm  
 Drahtschlingenelektrode, länglich, 45° abgewinkelt  
 Wire loop electrode, elongated, 45° angled  
 Electrodo de asa de alambre oblonga, acodado 45°  
 Electrode anse, forme allongée, coudée en 45°  
 Elettrodo ad ansa curva, angolo 45°



80-461-24-04  
 Fig. 24  
 8 x 5 mm  
 Drahtschlingenelektrode, rhombusförmig, Schaft 45° abgewinkelt  
 Wire loop electrode, rhombic, shaft 45° angled  
 Electrodo de asa de alambre romboidal, vástago acodado 45°  
 Electrode anse, rhomboïdale, tige coudée en 45°  
 Elettrodo ad ansa, forma di rombo, 8 x 5 mm, asta curva a 45°



80-461-31-04  
 Fig. 31  
 Ø 0,6 mm  
 Koagulations-Nadelelektrode, 45° abgewinkelt  
 Needle electrode for coagulation, 45° angled  
 Electrodo de aguja para la coagulación, acodado 45°  
 Electrode aiguille pour la coagulation, coudée en 45°  
 Elettrodo ad ago per coagulazione, asta curva a 45°



80-461-32-04  
 Fig. 32  
 Ø 1,7 mm  
 Koagulations-Nadelelektrode, 30° abgewinkelt  
 Needle electrode for coagulation, 30° angled  
 Electrodo de aguja para la coagulación, acodado 30°  
 Electrode aiguille pour la coagulation, coudée en 30°  
 Elettrodo ad ago per coagulazione, asta curva a 30°

**Elektroden mit Ø 1,6 mm**  
**Electrodes Ø 1.6 mm**  
**Electrodo con Ø 1,6 mm**  
**Electrodes Ø 1,6 mm**  
**Elettrodi Ø 1,6 mm**

Ø 1,6 mm  **max. 500 V<sub>p</sub>**



80-461-33-04

Fig. 33

Kugelelektrode, 45° abgewinkelt  
 Ball electrode, 45° angled  
 Electrodo de bola, 45° acodado  
 Electrode boule, coudée en 45°  
 Elettrodo a sfera, asta curva a 45°



80-461-34-04

Fig. 34

Kugelelektrode, 45° abgewinkelt  
 Ball electrode, 45° angled  
 Electrodo de bola, 45° acodado  
 Electrode boule, coudée en 45°  
 Elettrodo a sfera, asta curva a 45°



80-461-35-04

Fig. 35

Koagulations- und Fulgurationselektrode, gerade  
 Coagulation and fulguration electrode, straight  
 Electrodo para la coagulación y la fulguración, recto  
 Electrode de coagulation et fulguration, droite  
 Elettrodo per folgorazione e coagulazione, retto



80-461-36-04

Fig. 36

Koagulations- und Fulgurationselektrode, 90° abgewinkelt  
 Coagulation and fulguration electrode, 90° angled  
 Electrodo para la coagulación y la fulguración, acodado 90°  
 Electrode de coagulation et fulguration, coudée en 90°  
 Elettrodo per folgorazione e coagulazione, angolo 90°



80-461-37-04

Nadelelektrode, 45° abgewinkelt  
 Needle electrode, 45° angled  
 Electrodo de aguja, acodado 45°  
 Electrode aiguille, coudée en 45°  
 Elettrodo ad ago, angolo 45°



80-530-03-04

Elektrode für Besenreiser  
 Electrode for varices/spider-bursts  
 Electrodo para verrugas  
 Electrode pour varices  
 Elettrodo per varici



80-530-04-04

Couperosa-Elektrode  
 Electrode for rosacea/telangiectasias  
 Electrodo para couperosa  
 Electrode pour couperose  
 Elettrodo per cuperosa





**Elektroden mit Ø 0,8 mm**  
**Electrodes Ø 0.8 mm**  
**Electrodos con Ø 0,8 mm**  
**Electrodes Ø 0,8 mm**  
**Elettrodi Ø 0,8 mm**

Ø 0,8 mm

$\frac{1}{4}$    
Ø 0,45 mm      Ø 0,25 mm  
nicht isoliert  
non-insulated  
no aislado  
pas isolée  
non isolato

80-525-04-04

Nadelelektrode, 1 Dutzend  
Needle electrode, 1 dozen  
Electrodo de aguja, 1 docena  
Electrode aiguille, 1 douzaine  
Elettrodo ad ago, 1 dozzina

**Aktivelektroden mit Ø 4 mm**  
**Active electrodes Ø 4 mm**  
**Electrodos activos con Ø 4 mm**  
**Electrodes actives Ø 4 mm**  
**Elettrodi attivi Ø 4 mm**

Ø 4 mm

$\frac{1}{4}$    
Ø 4 mm

80-563-05-04

Faltenglättungselektrode  
Wrinkle smoothing electrode  
Electrodo antiarrugas  
Electrode pour lisser des rides  
Elettrodo per rughe

Elektroden-Adapter für monopolare Handgriffe  
Electrode adapter for monopolar handles  
Adaptador de electrodos para mangos monopolares  
Adaptateur pour manches monopolaires  
Adattatore elettrodo per manipoli monopolari

---

#### Elektrodenfixierung über Schraubkappe

Electrode fixation with screw cap

Fijación de electrodos con tapa roscada

Fixation de l'électrode à l'aide du bouchon à vis

Fissaggio elettrodo tramite tappo a vite



80-460-04-04 **max. 3700 Vp**

Adapter von Ø 4 mm auf Ø 1,6 mm, z.B. Dental-Elektroden  
Adapter from Ø 4 mm to Ø 1.6 mm, e.g. for dental electrodes  
Adaptador de Ø 4 mm a Ø 1,6 mm, p.e. para electrodos dentales  
Adaptateur de Ø 4 mm à Ø 1,6 mm, p.e. pour électrodes dentaires  
Adattatore da Ø 4 mm a Ø 1,6 mm, p.e. per elettrodi dentali



80-531-00-04 **max. 3700 Vp**

Adapter von Ø 4 mm auf Ø 3/32" = 2,4 mm  
Adapter from Ø 4 mm to Ø 3/32" = 2.4 mm  
Adaptador de Ø 4 mm a Ø 3/32" = 2,4 mm  
Adaptateur de Ø 4 mm à Ø 3/32" = 2,4 mm  
Adattatore da Ø 4 mm a Ø 3/32" = 2,4 mm



80-532-00-04 **max. 3700 Vp**

Adapter von Ø 4 mm auf Ø 0,8 mm  
Adapter from Ø 4 mm to Ø 0.8 mm  
Adaptador de Ø 4 mm a Ø 0,8 mm  
Adaptateur de Ø 4 mm à Ø 0,8 mm  
Adattatore da Ø 4 mm a Ø 0,8 mm

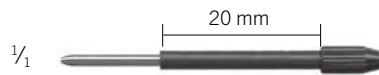

80-533-00-04 **max. 50 Vp**

Adapter von Ø 1,6 mm auf Ø 0,8 mm  
Adapter from Ø 1.6 mm to Ø 0.8 mm  
Adaptador de Ø 1,6 mm a Ø 0,8 mm  
Adaptateur de Ø 1,6 mm à Ø 0,8 mm  
Adattatore da Ø 1,6 mm a Ø 0,8 mm

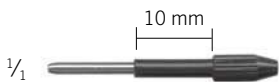

80-533-01-04 **max. 50 Vp**

Adapter von Ø 1,6 mm auf Ø 0,8 mm  
Adapter from Ø 1.6 mm to Ø 0.8 mm  
Adaptador de Ø 1,6 mm a Ø 0,8 mm  
Adaptateur de Ø 1,6 mm à Ø 0,8 mm  
Adattatore da Ø 1,6 mm a Ø 0,8 mm

Elektrodenbehälter  
Containers for electrodes  
Contenedores para electrodos  
Boîtes pour électrodes  
Contenitori per elettrodi

Monopolare Elektroden  
Monopolar electrodes  
Electrodos monopolares  
Électrodes monopolaires  
Elettrodi monopolari



2



80-408-00-01

für 8 Elektroden mit Schaft Ø 4 mm  
for 8 electrodes with shaft Ø 4 mm  
para 8 electrodos con vástago de Ø de 4 mm  
pour 8 électrodes à tige de Ø 4 mm  
per 8 elettrodi con asta di Ø 4 mm



80-444-08-01

für 8 Elektroden mit Schaft Ø 1,6 mm  
for 8 electrodes with shaft Ø 1.6 mm  
para 8 electrodos con vástago de Ø de 1,6 mm  
pour 8 électrodes à tige de Ø 1,6 mm  
per 8 elettrodi con asta di Ø 1,6 mm



80-416-00-01

für 16 Elektroden mit Schaft Ø 4 mm  
for 16 electrodes with shaft Ø 4 mm  
para 16 electrodos con vástago de Ø de 4 mm  
pour 16 électrodes à tige de Ø 4 mm  
per 16 elettrodi con asta di Ø 4 mm



55-803-70-04

277 x 172 x 29 mm  
Lagerungsset für monopolare Elektroden Ø 1,6, 2,4 und 4 mm  
Storage rack for monopolar electrodes Ø 1.6, 2.4 and 4 mm  
Almacenaje por electrodos monopolares Ø 1,6, 2,4 y 4 mm  
Rangement pour électrodes monopolaires Ø 1,6, 2,4 et 4 mm  
Supporto per elettrodi monopolari Ø 1,6, 2,4 e 4 mm

Isolit-Pinzetten  
 Isolit forceps  
 Pinzas Isolit  
 Pincas Isolit  
 Pinze Isolit



80-285-40-04 80-285-50-04 **max. 4000 Vp**  
 4 m 5 m

Anschlusskabel für Isolit-Pinzetten und Zubehör aus unserem früheren Geräteprogramm  
 Connection cable for Isolit forceps and older KLS Martin instruments (former product line)  
 Cable de conexión para pinzas Isolit e instrumentos de nuestra anterior gama de equipos  
 Câble de raccordement pour des pincas Isolit et pour des instruments de notre ancien programme d'appareils  
 Cavo di connessione per pinze Isolit e strumenti del nostro precedente programma degli apparecchi



80-285-55-04 **max. 4000 Vp**  
 4 m

Anschlusskabel für Isolit-Pinzetten, mit 3-Pin-Stecker  
 Connecting cable for Isolit forceps, with 3-pin plug  
 Cable de conexión para pinzas Isolit, con clavija de tres patillas  
 Câble de raccordement pour pincas Isolit, avec fiche à 3 broches  
 Cavo di collegamento per pinzette Isolit, con spina a 3 pin



83-124-52-04 **max. 4000 Vp**  
 4 m

maXium® i, ME MB 3 i, ME MB 2 i und Valleylab-Geräte  
 → für Isolit-Pinzetten  
 maXium® i, ME MB 3 i, ME MB 2 i and Valleylab units  
 → for Isolit forceps  
 maXium® i, ME MB 3 i, ME MB 2 i y aparatos Valleylab  
 → para pinzas Isolit  
 maXium® i, ME MB 3 i, ME MB 2 i et appareils Valleylab  
 → pour des pincas Isolit  
 maXium® i, ME MB 3 i, ME MB 2 i e apparecchi Valleylab  
 → per pinze Isolit

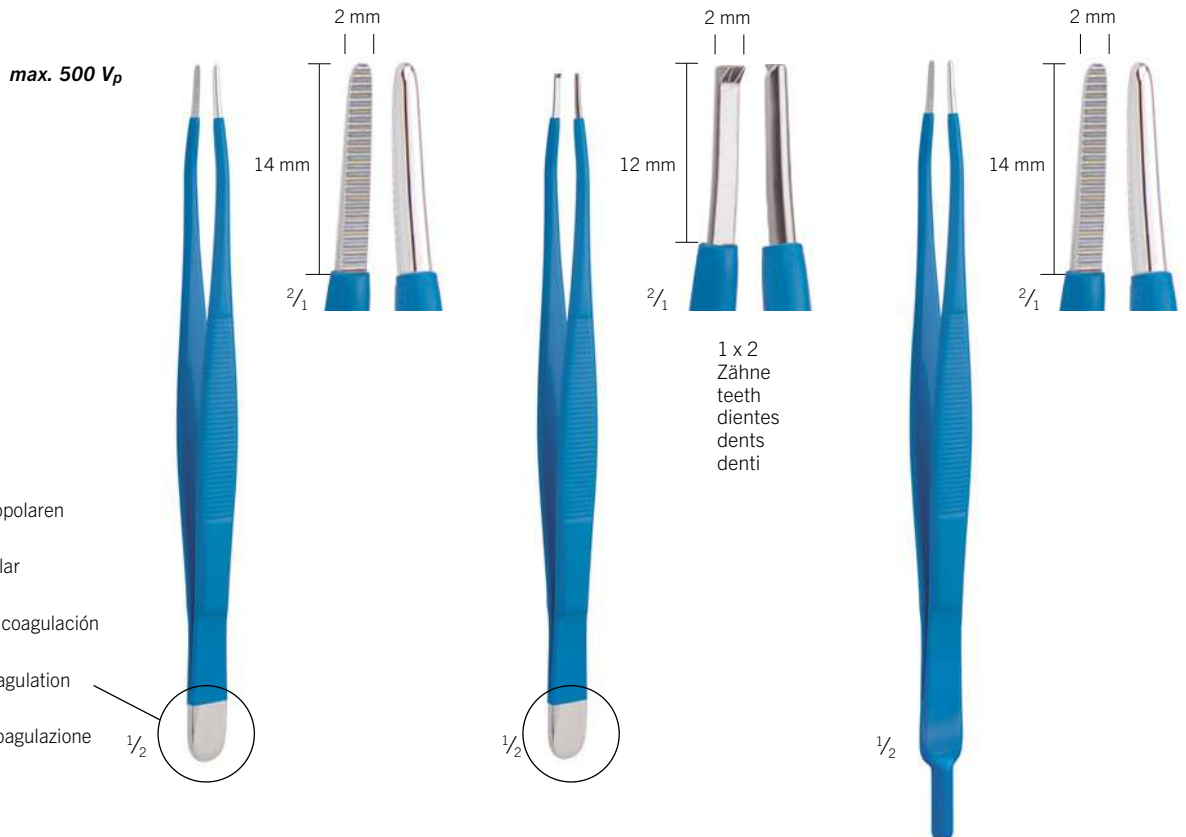

**max. 500 Vp**

Kontaktbereich zur monopolaren Klemmenkoagulation  
 Contact area for monopolar forceps coagulation  
 Área de contacto para la coagulación monopolar con pinzas  
 Zone de contact pour coagulation par pince monopolaire  
 Zona di contatto per la coagulazione con pinza monopolare

80-900-18-03 = 18 cm  
 80-900-21-03 = 21 cm  
 80-900-25-03 = 25 cm

80-901-18-03 = 18 cm  
 80-901-21-03 = 21 cm  
 80-901-25-03 = 25 cm

80-902-18-03 = 18 cm  
 80-902-21-03 = 21 cm  
 80-902-25-03 = 25 cm  
 mit Buchse für Kabel  
 with socket for cable  
 con conexión para cable  
 avec prise pour câble  
 con presa per cavo



83-120-50-04 **max. 4000 Vp**  
 5 m  
 Anschlusskabel  
 Connection cable  
 Cable de conexión  
 Câble de raccordement  
 Cavo di connessione



83-120-51-04 **max. 4000 Vp**  
 5 m  
 Anschlusskabel  
 Connection cable  
 Cable de conexión  
 Câble de raccordement  
 Cavo di connessione

83-520-39-04 **max. 1500 Vp**  
 47 cm  
 Hakenelektrode, Ø 5 mm, isoliert,  
 Hakenlänge 5 mm  
 Hook electrode, Ø 5 mm, insulated,  
 hook length 5 mm  
 Electrodo de gancho, Ø 5 mm, aislado,  
 longitud del gancho 5 mm  
 Electrode crochet, Ø 5 mm, isolée,  
 longueur du crochet de 5 mm  
 Elettrodo ad uncino, Ø 5 mm, isolato,  
 lunghezza del gancio 5 mm

# 3

Neutralelektroden  
Neutral electrodes  
Placas neutras  
Electrodes neutres  
Elettrodi neutri





mit 6,3-mm-NE-Stecker  
with 6.3-mm NE plug  
con clavija de PN de 6,3 mm  
avec fiche EN de 6,3 mm  
con spina EN da 6,3 mm

80-342-03-04

4 m

15 x 26 cm

Gummi-Neutralelektrode für Erwachsene,  
ungeteilte Kontaktfläche 370 cm<sup>2</sup>

Rubber neutral electrode for adults,  
single contact surface 370 cm<sup>2</sup>

Placa neutra de goma para adultos,  
superficie de contacto no dividida de 370 cm<sup>2</sup>

Electrode neutre en caoutchouc pour adultes,  
surface de contact non divisée de 370 cm<sup>2</sup>

Elettrodo neutro di gomma per adulti,  
superficie integrale di contatto da 370 cm<sup>2</sup>



mit US-NE-Stecker  
with US NE plug  
con clavija de PN tipo US  
avec fiche EN US  
con spina EN US

80-342-04-04

4 m

15 x 26 cm

Gummi-Neutralelektrode für Erwachsene,  
ungeteilte Kontaktfläche 370 cm<sup>2</sup>

Rubber neutral electrode for adults,  
single contact surface 370 cm<sup>2</sup>

Placa neutra de goma para adultos,  
superficie de contacto no dividida de 370 cm<sup>2</sup>

Electrode neutre en caoutchouc pour adultes,  
surface de contact non divisée de 370 cm<sup>2</sup>

Elettrodo neutro di gomma per adulti,  
superficie integrale di contatto da 370 cm<sup>2</sup>

80-332-03-04

4 m

8 x 16 cm

Gummi-Neutralelektrode für Kinder,  
ungeteilte Kontaktfläche 120 cm<sup>2</sup>

Rubber neutral electrode for children,  
single contact surface 120 cm<sup>2</sup>

Placa neutra de goma para niños,  
superficie de contacto no dividida de 120 cm<sup>2</sup>

Electrode neutre en caoutchouc pour enfants,  
surface de contact non divisée de 120 cm<sup>2</sup>

Elettrodo neutro di gomma per bambini,  
superficie integrale di contatto da 120 cm<sup>2</sup>

80-342-05-04

4 m

8 x 16 cm

Gummi-Neutralelektrode für Kinder,  
ungeteilte Kontaktfläche 120 cm<sup>2</sup>

Rubber neutral electrode for children,  
single contact surface 120 cm<sup>2</sup>

Placa neutra de goma para niños,  
superficie de contacto no dividida de 120 cm<sup>2</sup>

Electrode neutre en caoutchouc pour enfants,  
surface de contact non divisée de 120 cm<sup>2</sup>

Elettrodo neutro di gomma per bambini,  
superficie integrale di contatto da 120 cm<sup>2</sup>



80-342-07-04

Twin-Pad II – Zweiflächen-Neutralelektrode, Kontaktfläche 200 cm<sup>2</sup>  
(1 x 80-294-40-04/80-294-43-04/80-294-44-04 + 1 x 80-372-00-04 erforderlich)  
Twin-Pad II neutral electrode with two contact surfaces (split), contact surface 200 cm<sup>2</sup>  
(1 x 80-294-40-04/80-294-43-04/80-294-44-04 + 1 x 80-372-00-04 required)  
Placa neutrale Twin-Pad II con dos superficies, superficie de contacto de 200 cm<sup>2</sup>  
(preciso 1 x 80-294-40-04/80-294-43-04/80-294-44-04 + 1 x 80-372-00-04)  
Twin-Pad II électrode neutre double, surface de contact 200 cm<sup>2</sup>  
(nécessite 1 x 80-294-40-04/80-294-43-04/80-294-44-04 + 1 x 80-372-00-04)  
Twin-Pad II piastra neutrale con due superficie, superficie di contatto da 200 cm<sup>2</sup>  
(1 x 80-294-40-04/80-294-43-04/80-294-44-04 + 1 x 80-372-00-04)

Für die Verwendung der Twin Pad II wird die Verwendung eines Stützstrumpfs der Kompressionsklasse 1 empfohlen.

When using the Twin Pad II, the use of a compression Class 1 support stocking is recommended.

Durante el uso de Twin Pad II, se recomienda llevar una media de soporte de clase de compresión 1.

En cas d'utilisation du Twin Pad II, il est recommandé de porter un bas de contention correspondant à la classe de compression 1.

Per l'impiego del Twin Pad II si raccomanda di utilizzare una calza di sostegno della classe di compressione 1.



80-370-50-04 = 50 cm/20"  
80-371-00-04 = 100 cm/40"  
Gummibinden, gelocht  
Rubber bands, with holes  
Cintas de goma, perforadas  
Bandes caoutchouc, perforées  
Nastri in gomma, con fori



80-371-01-04  
Knopf für Gummibinde  
80-370-50-04 + 80-371-00-04  
Button for rubber band  
80-370-50-04 + 80-371-00-04  
Botón para la cinta de goma  
80-370-50-04 + 80-371-00-04  
Bouton pour bande caoutchouc  
80-370-50-04 + 80-371-00-04  
Bottone per nastro in gomma  
80-370-50-04 + 80-371-00-04



80-372-00-04  
Textilband mit Klettverschluss, 90 cm,  
waschbar bei 60 °C  
Textile band with velcro strap, 90 cm,  
washable at 60°C  
Tira auto-adhesiva, 90 cm,  
lavable a 60 °C  
Bande auto-adhésive, 90 cm,  
lavable à 60 °C  
Nastro in velcro, 90 cm,  
lavabile a 60 °C



Wiederverwendbare Neutralelektroden  
Reusable neutral electrodes  
Placas neutras reutilizables  
Electrodes neutres réutilisables  
Elettrodi neutri riutilizzabili



mit 6,3-mm-NE-Stecker  
with 6.3-mm NE plug  
con clavija de PN de 6,3 mm  
avec fiche EN de 6,3 mm  
con spina EN da 6,3 mm



80-371-02-04

Knopf für KLS Martin Twin-Pad 80-342-06-04  
Button for KLS Martin Twin-Pad 80-342-06-04  
Botón para la KLS Martin Twin-Pad 80-342-06-04  
Bouton pour KLS Martin Twin-Pad 80-342-06-04  
Bottone per KLS Martin Twin-Pad 80-342-06-04

80-342-06-04

4 m

15 x 26 cm

Twin-Pad-Zweiflächen-Neutralelektrode, ohne Knöpfe, Kontaktfläche 256 cm<sup>2</sup>,  
(2 x 80-371-02-04 + 1 x 80-370-50-04/ 80-371-00-04 erforderlich)

Twin-Pad neutral electrode with two contact surfaces (split), without buttons,  
contact surface 256 cm<sup>2</sup>, (2 x 80-371-02-04 + 1 x 80-370-50-04/ 80-371-00-04 required)

Placa neutra Twin-Pad con dos superficies, sin botones, superficie de contacto  
de 256 cm<sup>2</sup>, (preciso 2 x 80-371-02-04 + 1 x 80-370-50-04 /80-371-00-04)

Twin-Pad électrode neutre double, réutilisable, sans boutons, surface de  
contact 256 cm<sup>2</sup>, (nécessite 2 x 80-371-02-04 + 1 x 80-370-50-04 /80-371-00-04)

Twin-Pad piastra neutra con due superfici, senza bottoni, superficie di contatto  
da 256 cm<sup>2</sup>, (necessario 2 x 80-371-02-04 + 1 x 80-370-50-04/80-371-00-04)

Hinweis:

Diese Neutralelektrode darf nicht mit den HF-Generatoren  
maXium®, maXium® smart C, miniCutter, ME 102 und MD 62 eingesetzt werden!

Notice:

This neutral electrode must not be used with the maXium®, maXium® smart C,  
miniCutter, ME 102 and MD 62 HF generators!

Indicación:

¡Esta placa neutra no debe utilizarse con el generadores  
de maXium®, maXium® smart C, miniCutter, ME 102 y MD 62!

Indication:

Défense d'utiliser cette électrode neutre avec les  
générateurs HF maXium®, maXium® smart C, miniCutter, ME 102 et MD 62!

Avvertenza:

questo elettrodo neutro non può essere usato con il  
generatori AF maXium®, maXium® smart C, miniCutter, ME 102 e MD 62!



mit 6,3-mm-NE-Stecker  
with 6.3-mm NE plug  
con clavija de PN de 6,3 mm  
avec fiche EN de 6,3 mm  
con spina EN da 6,3 mm

**Handzylinder als Erdungshilfe bei monoterminalen  
Anwendungen mit dem MD 62**

**Hand cylinder as a grounding aid in monoterminial  
applications with the MD 62**

**Cilindro de mano como ayuda de puesta a tierra  
en aplicaciones monoterminales con el MD 62**

**Cylindre à main comme aide à la mise à la terre  
dans les applications monoterminales avec le MD 62**

**Cilindro manuale come aiuto di messa a terra  
in applicazioni monoterminali con MD 62**

80-310-04-04

Handzylinder für MD 62, mit 4 m Kabel  
Hand cylinder for MD 62, with cable of 4 m  
Cilindro de mano para MD 62, con cable de 4 m  
Cylindre à main pour MD 62, avec câble de 4 m  
Cilindro manuale per MD 62, con cavo de 4 m

Einmal-Neutralelektroden  
Disposable neutral electrodes  
Placas neutras desechables  
Electrodes neutres à usage unique  
Elettrodi neutri monouso

---



80-294-40-04  
4 m  
KLS Martin



80-294-43-04  
4 m  
**maXium® e**  
Erbe



80-294-44-04  
4 m  
**maXium® i**  
**maXium® smart C**  
ME MB 3 i  
ME MB 2 i  
Valleylab

Anschlusskabel für Einmal-Neutralelektroden  
Connection cable for disposable neutral electrodes  
Cable de conexión para placas neutras desechables  
Câble de raccordement pour électrodes neutres à usage unique  
Cavo di connessione per elettrodi neutri monouso

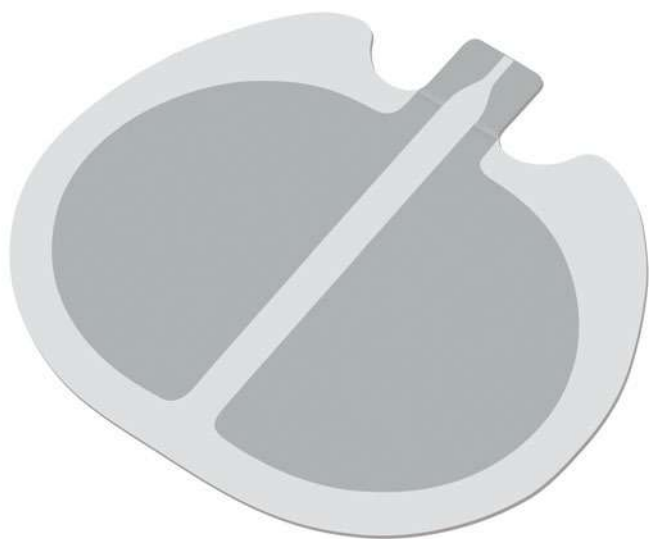

80-344-09-04

PCS-DuoSafe-Einmal-Neutralelektrode für Erwachsene und Kinder, geteilte Kontaktfläche 107 cm<sup>2</sup>, ohne Anschlusskabel, 50 Stück/VE  
PCS DuoSafe disposable neutral electrode for adults and children, split contact surface 107 cm<sup>2</sup>, without connection cable, 50/pack  
Placa neutra desechable tipo PCS DuoSafe con dos partes separadas 107 cm<sup>2</sup> para adultos y niños, sin cable de conexión, 50 piezas/unidad  
Electrode neutre à usage unique type PCS DuoSafe avec deux surfaces de contact séparées 107 cm<sup>2</sup> pour adultes et enfants, sans câble de raccordement, 50 pièces/unité  
Elettrodo neutro monouso tipo PCS DuoSafe con due superfici separate 107 cm<sup>2</sup> per adulti e bambini, senza cavo di connessione, 50 pezzi/unità

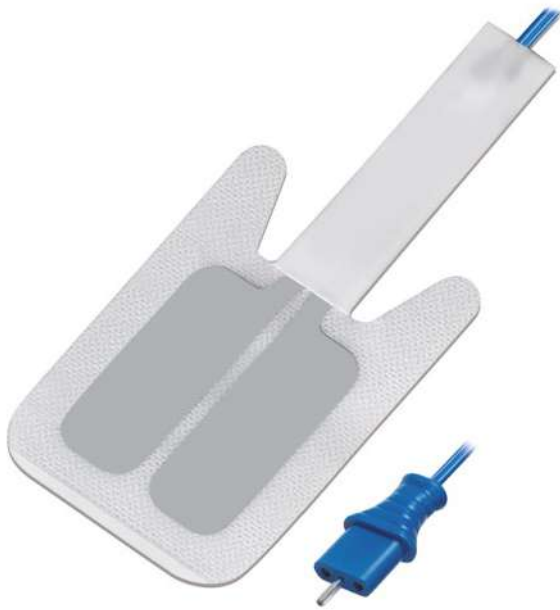

80-344-12-04

PCS DuoSafe Einmal-Neutralelektrode für Neugeborene und Babies bis max. 5,0 kg Körpergewicht, geteilte Kontaktfläche 33 cm<sup>2</sup>, mit Anschlusskabel International, 10 Stück/VE

PCS DuoSafe disposable neutral electrode for newborns and babies up to a maximum weight of 5.0 kg, split contact surface, 33 cm<sup>2</sup>, with international connecting cable, 10 items/pack

PCS DuoSafe placa neutra desechable para neonatos y bebés hasta un peso máximo de 5,0 kg, superficie de contacto dividida de 33 cm<sup>2</sup>, con cable de conexión internacional, 10 unidades/envase

PCS DuoSafe Électrode neutre à usage unique pour nouveau-nés et bébés dont le poids max. est de 5,0 kg, surface de contact divisée 33 cm<sup>2</sup>, avec câble de raccordement international, 10 pièces/unité

Elettrodo neutro monouso PCS DuoSafe per neonati e bebè fino ad un peso massimo di 5,0 kg, superficie di contatto separata di 33 cm<sup>2</sup>, con cavo di collegamento internazionale, 10 unità/UV



maXium<sup>®</sup> Baby



maXium<sup>®</sup> smart C Baby



80-344-11-04 **max. 500 V<sub>p</sub>**

Adapter mit internationaler NE-Buchse und 6,3-mm-Stecker  
Adapter with international NE socket and 6.3-mm plug  
Adaptador con hembra de PN internacional y clavija de 6,3 mm  
Adaptateur avec fiche EN internationale et fiche 6,3 mm  
Adattatore con presa EN internazionale e spina da 6,3 mm

Diese Neutralelektrode (80-344-12-04) darf nur mit dem HF-Gerät **maXium<sup>®</sup>** (Typ ME 402) (ab Hardwarestand 06 sowie Softwarestand größer V 3.404) und dem **maXium<sup>®</sup> smart C** verwendet werden! Es ist ist der dafür vorgesehene Baby-NE-Modus zu wählen!





This neutral electrode (80-344-12-04) may only be used with the **maXium<sup>®</sup>** HF generator (type ME 402) (from hardware status 06 and software status higher than V 3.404) and the **maXium<sup>®</sup> smart C**! The Baby NE mode intended for this neutral electrode must be selected in this case!

¡Esta placa neutra (80-344-12-04) sólo debe utilizarse con el equipo de AF **maXium<sup>®</sup>** (tipo ME 402) (a partir del estado de hardware 06 y con estado de software superior a V 3.404) y el **maXium<sup>®</sup> smart C**! ¡En todo caso deberá seleccionarse el modo de PN para bebé previsto!

Cette électrode neutre (80-344-12-04) ne peut être utilisée qu'avec l'appareil HF **maXium<sup>®</sup>** (type ME 402), (à partir des versions matérielle HW06 et logicielle supérieure à V3.404) et le **maXium<sup>®</sup> smart C**! Il faut sélectionner le mode EN Bébé prévu à cet effet!

Questo elettrodo neutro (80-344-12-04) può essere usato solo con l'apparecchio AF **maXium<sup>®</sup>** (tipo ME 402) (a partire dalla versione hardware 06 e dalla versione software superiore a V 3.404) e **maXium<sup>®</sup> smart C**! In questo caso occorre selezionare la modalità speciale EN per bebè prevista allo scopo!

Zuordnungsübersicht Geräte/Neutralelektroden  
 Assignment electrosurgery units/neutral electrodes  
 Sinopsis de asignación aparatos/placas neutras  
 Classification sommaire appareils/électrodes neutres  
 Schema delle corrispondenze apparecchi/elettrodi neutri

Art.-Nr. Item No. N.º ref. Réf. Codice art.	Gerät Type of unit Tipo del aparato Type d'appareil Tipo d'apparecchio	Twin Pad  80-342-07-04	Für Erwachsene For adults Para adultos Pour adultes Per adulti (6,3 mm) 80-342-03-04	Für Kinder For children Para niños Pour enfants Per bambini (6,3 mm) 80-332-03-04	Für Erwachsene For adults Para adultos Pour adultes Per adulti (US-NE) 80-342-04-04	Für Kinder For children Para niños Pour enfants Per bambini (US-NE) 80-342-05-04
80-042-00-04	maXium® <b>m</b>	x	x	x		
80-042-02-04	maXium® <b>i</b>	x			x	x
80-042-04-04	maXium® <b>e</b>	x	x	x		
80-043-00-04	maXium® smart C <b>m</b>	x			x	x
80-043-01-04	maXium® smart C <b>i</b>	x			x	x
80-043-02-04	maXium® smart C <b>e</b>	x			x	x
80-041-01-04	Martin ME 411	x	x	x		
80-040-00-04	Martin ME 400	x	x	x		
80-040-11-04	ME MB 3 <b>m</b>	x	x	x		
80-040-12-04	ME MB 3 <b>i</b>	x			x	x
80-010-02-04	Martin ME 102	x	x	x		
80-008-03-04	miniCutter	x	x	x		
			 150 x 260 mm	 80 x 100 mm	 150 x 260 mm	 80 x 100 mm



Anschlusskabel Einmal-Neutralelektroden Connection cable disposable neutral electrodes Cable de conexión placas neutras desechables Câble de raccordement électrodes neutres à usage unique Cavo di connessione elettrodi neutri monouso			Einmal-Neutralelektrode Disposable neutral electrode Placa neutra desechable Electrode neutre à usage unique Elettrodo neutro monouso	Einmal-Neutralelektrode Babies Disposable neutral electrode babies Placa neutra desechable bebés Electrode neutre à usage unique bébés Elettrodo neutro monouso bebè	
80-294-40-04	80-294-43-04	80-294-44-04	80-344-09-04	80-344-12-04	80-344-12-04 80-344-11-04
X			X		X
		X	X	X	
	X		X		X
		X	X	X	
		X	X	X	
		X	X	X	
X			X		
X			X		
X			X		
		X	X		
X			X		
X			X		
<p>80-294-40-04      80-294-43-04      80-294-44-04</p>				<p>80-344-12-04</p> <p>80-344-11-04</p>	

Bipolares Zubehör  
Bipolar accessories  
Accesorios bipolares  
Accessoires bipolaires  
Accessori bipolari

# 4





max. 600 V<sub>p</sub>



max. 600 V<sub>p</sub>



max. 600 V<sub>p</sub>

80-287-33-04 80-287-53-04  
 3 m 5 m

KLS-Martin- und Berchtold-Geräte  
 → bipolare Instrumente  
 KLS Martin and Berchtold units  
 → bipolar instruments  
 Aparatos KLS Martin y Berchtold  
 → instrumentos bipolares  
 Appareils KLS Martin et Berchtold  
 → instruments bipolaires  
 Apparecchi KLS Martin e Berchtold  
 → strumenti bipolari

80-286-30-04 80-286-50-04  
 3 m 5 m

maXium® e / Erbe-Geräte ICC und ACC/VIO  
 → bipolare Instrumente  
 maXium® e / ICC and ACC/VIO Erbe units  
 → bipolar instruments  
 maXium® e / aparatos Erbe ICC e ACC/VIO  
 → instrumentos bipolares  
 maXium® e / appareils Erbe ICC et ACC/VIO  
 → instruments bipolaires  
 maXium® e / apparecchi Erbe ICC e ACC/VIO  
 → strumenti bipolari

80-287-89-04 80-287-90-04  
 3 m 5 m

maXium® i, ME MB 3 i, ME MB 2 i / Valleylab-Geräte  
 → bipolare Instrumente  
 maXium® i, ME MB 3 i, ME MB 2 i / Valleylab units  
 → bipolar instruments  
 maXium® i, ME MB 3 i, ME MB 2 i / aparatos Valleylab  
 → instrumentos bipolares  
 maXium® i, ME MB 3 i, ME MB 2 i / appareils Valleylab  
 → instruments bipolaires  
 maXium® i, ME MB 3 i, ME MB 2 i / apparecchi Valleylab  
 → strumenti bipolari

**Standard-Version** max. 300 V<sub>p</sub>  
**Standard version**  
**Versión estándar**  
**Version standard**  
**Versione standard**



80-570-18-04  
 marCut® Standard  
 18 cm



80-570-21-04  
 marCut® Standard  
 21 cm



80-570-23-04  
 marCut® Standard  
 23 cm



80-570-28-04  
 marCut® Standard  
 28 cm





max. 600 V<sub>p</sub>

80-287-72-04

5 m

Codman- und Valleylab-Geräte  
 → bipolare Instrumente

Codman and Valleylab units  
 → bipolar instruments

Aparatos Codman y Valleylab  
 → instrumentos bipolares

Appareils Codman et Valleylab  
 → instruments bipolaires

Apparecchi Codman e Valleylab  
 → strumenti bipolari



80-570-00-04

Protector für die Aufbereitung. Wir empfehlen dringend die Verwendung des Protectors für die Aufbereitung der Schere.

Protector for instrument processing. We strongly recommend using the protector when reprocessing the scissors.

Protector para el tratamiento. Recomendamos encarecidamente la utilización del protector para el tratamiento de las tijeras.

Protecteur pour la préparation. Nous recommandons expressément l'utilisation du protecteur pour la préparation des ciseaux.

Protettore per il trattamento. Si consiglia vivamente l'uso del protettore per il trattamento delle forbici.



Weitere Informationen entnehmen Sie bitte der separaten Broschüre.

For further information please refer to our separate product brochure.

Encontrará informaciones adicionales en el folleto individual.

Vous trouverez des informations supplémentaires dans la brochure.

Per ulteriori informazioni vedasi il prospetto separato.

Slim Line

Schlanke Version max. 300 V<sub>p</sub>

Slim model

Versión delgada

Version élancée

Modello sottile



80-571-18-04  
 marCut® SL  
 18 cm



80-571-21-04  
 marCut® SL  
 21 cm



80-571-23-04  
 marCut® SL  
 23 cm



80-571-28-04  
 marCut® SL  
 28 cm



80-287-33-04 80-287-53-04  
 3 m 5 m

KLS-Martin- und Berchtold-Geräte  
 → bipolare Instrumente  
 KLS Martin and Berchtold units  
 → bipolar instruments  
 Aparatos KLS Martin y Berchtold  
 → instrumentos bipolares  
 Appareils KLS Martin et Berchtold  
 → instruments bipolaires  
 Apparecchi KLS Martin e Berchtold  
 → strumenti bipolari



80-286-30-04 80-286-50-04  
 3 m 5 m

maXium® e / Erbe-Geräte ICC und ACC/VIO  
 → bipolare Instrumente  
 maXium® e / ICC and ACC/VIO Erbe units  
 → bipolar instruments  
 maXium® e / aparatos Erbe ICC e ACC/VIO  
 → instrumentos bipolares  
 maXium® e / appareils Erbe ICC et ACC/VIO  
 → instruments bipolaires  
 maXium® e / apparecchi Erbe ICC e ACC/VIO  
 → strumenti bipolari



80-287-89-04 80-287-90-04  
 3 m 5 m

maXium® i, ME MB 3 i, ME MB 2 i / Valleylab-Geräte  
 → bipolare Instrumente  
 maXium® i, ME MB 3 i, ME MB 2 i / Valleylab units  
 → bipolar instruments  
 maXium® i, ME MB 3 i, ME MB 2 i / aparatos Valleylab  
 → instrumentos bipolares  
 maXium® i, ME MB 3 i, ME MB 2 i / appareils Valleylab  
 → instruments bipolaires  
 maXium® i, ME MB 3 i, ME MB 2 i / apparecchi Valleylab  
 → strumenti bipolari

Super Slim Line

**Superschlanke Version**  
**Super slim model**  
**Versión super delgada**  
**Version super mince**  
**Versione extra snella**

max. 300 V<sub>p</sub>



80-572-13-04  
 marCut® SSL  
 13 cm

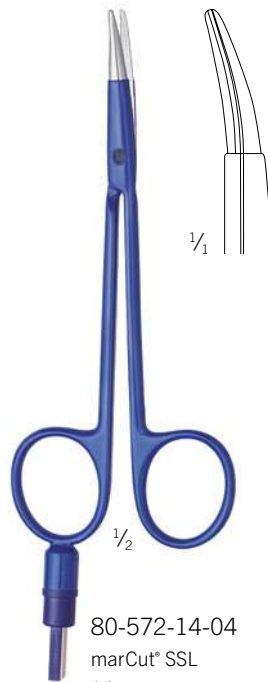

80-572-14-04  
 marCut® SSL  
 14 cm



80-572-17-04  
 marCut® SSL  
 17 cm



80-287-72-04  
 5 m

Codman- und Valleylab-Geräte  
 → bipolare Instrumente  
 Codman and Valleylab units  
 → bipolar instruments  
 Aparatos Codman y Valleylab  
 → instrumentos bipolares  
 Appareils Codman et Valleylab  
 → instruments bipolaires  
 Apparecchi Codman e Valleylab  
 → strumenti bipolari



80-570-00-04

Protector für die Aufbereitung. Wir empfehlen dringend die Verwendung des Protectors für die Aufbereitung der Schere.  
 Protector for instrument processing. We strongly recommend using the protector when reprocessing the scissors.  
 Protector para el tratamiento. Recomendamos encarecidamente la utilización del protector para el tratamiento de las tijeras.  
 Protecteur pour la préparation. Nous recommandons expressément l'utilisation du protecteur pour la préparation des ciseaux.  
 Protettore per il trattamento. Si consiglia vivamente l'uso del protettore per il trattamento delle forbici.



Weitere Informationen entnehmen Sie bitte der separaten Broschüre.  
 For further information please refer to our separate product brochure.  
 Encontrará informaciones adicionales en el folleto individual.  
 Vous trouverez des informations supplémentaires dans la brochure.  
 Per ulteriori informazioni vedasi il prospetto separato.

4

Beispielabbildung  
 Example illustration  
 Ilustración a modo de ejemplo  
 Illustration à titre d'exemple  
 Figura di esempio



mit geradem Stecker  
 with straight plug  
 con clavija recta  
 avec fiche droite  
 con spina diritta

max. 500 V<sub>p</sub>

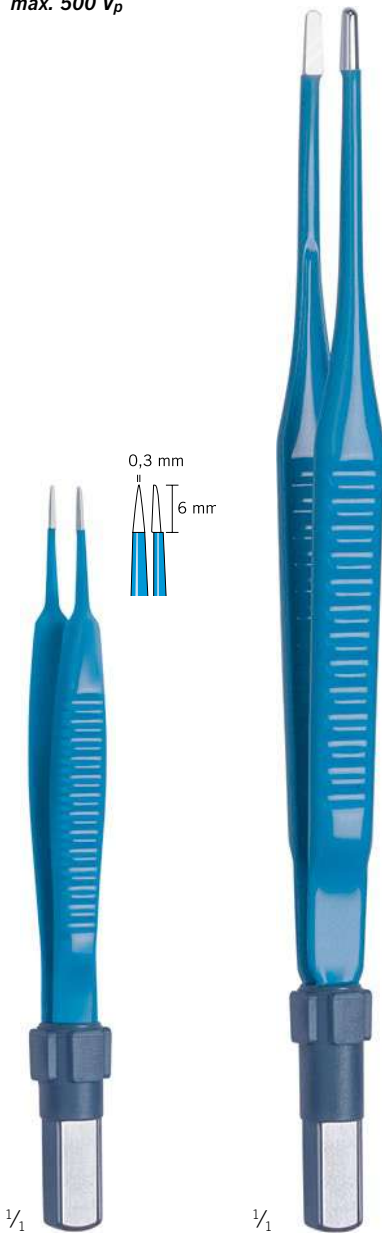

80-910-07-04  
 8,5 cm  
 spitz, 0,3 mm  
 pointed, 0,3 mm  
 puntiaguda, 0,3 mm  
 pointue, 0,3 mm  
 acuta, 0,3 mm

Beispielabbildung  
 Example illustration  
 Ilustración a modo de ejemplo  
 Illustration à titre d'exemple  
 Figura di esempio

**Bipolare Pinzetten, gerade**  
**Bipolar forceps, straight**  
**Pinzas bipolares, rectas**  
**Pincas bipolaires, droites**  
**Pinze bipolarari, diritte**

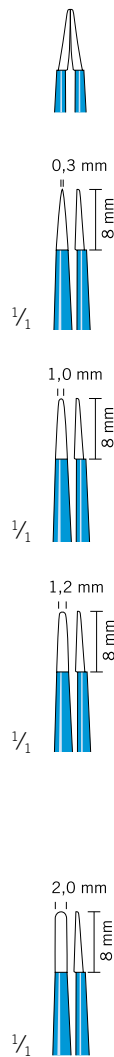

Spitzenbreite Tip width Ancho de la punta Largeur des pointes Larghezza delle punte	Länge Length Longitud Longueur Lunghezza	Artikel-Nr. Item No. N.º referencia Référence Codice articolo
---	--	---

**spitz/pointed/puntiaguda/pointue/acuta**

0,3 mm	12 cm	80-910-12-04
0,3 mm	16 cm	80-910-16-04
0,3 mm	18 cm	80-910-18-04
0,3 mm	20 cm	80-910-20-04
0,3 mm	22 cm	80-910-22-04

**stumpf/blunt/roma/mousse/smussa**

1,0 mm	12 cm	80-924-12-04
--------	-------	--------------

**stumpf/blunt/roma/mousse/smussa**

1,2 mm	16 cm	80-924-16-04
1,2 mm	18 cm	80-924-18-04
1,2 mm	20 cm	80-924-20-04
1,2 mm	22 cm	80-924-22-04
1,2 mm	24 cm	80-924-24-04
1,2 mm	26 cm	80-924-26-04
1,2 mm	30 cm	80-924-30-04

**stumpf/blunt/roma/mousse/smussa**

2,0 mm	12 cm	80-934-12-04
2,0 mm	16 cm	80-934-16-04
2,0 mm	18 cm	80-934-18-04
2,0 mm	20 cm	80-934-20-04
2,0 mm	22 cm	80-934-22-04
2,0 mm	24 cm	80-934-24-04
2,0 mm	26 cm	80-934-26-04
2,0 mm	30 cm	80-934-30-04



max. 500 V<sub>p</sub>

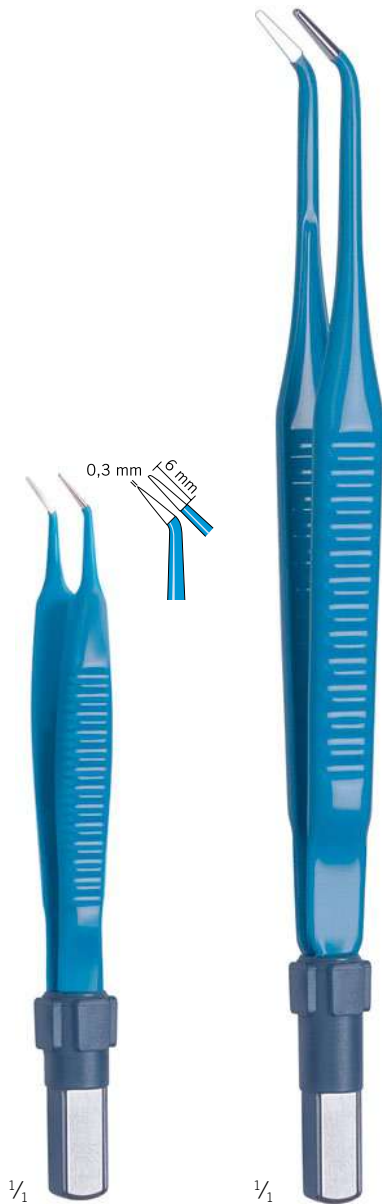

80-911-07-04  
 8,5 cm  
 spitz, 0,3 mm  
 pointed, 0,3 mm  
 puntiaguda, 0,3 mm  
 pointue, 0,3 mm  
 acuta, 0,3 mm

Beispielabbildung  
 Example illustration  
 Ilustración a modo de ejemplo  
 Illustration à titre d'exemple  
 Figura di esempio

**Bipolare Pinzetten, gewinkelt**  
**Bipolar forceps, angled**  
**Pinzas bipolares, acodadas**  
**Pinces bipolaires, coudées**  
**Pinze bipolari, piegate**

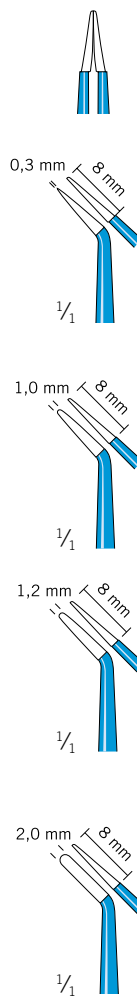

Spitzenbreite Tip width Ancho de la punta Largeur des pointes Larghezza delle punte	Länge Length Longitud Longueur Lunghezza	Artikel-Nr. Item No. N.º referencia Référence Codice articolo
---	--	---

**spitz/pointed/puntiaguda/pointue/acuta**

0,3 mm	12 cm	80-911-12-04
0,3 mm	16 cm	80-911-16-04
0,3 mm	18 cm	80-911-18-04
0,3 mm	20 cm	80-911-20-04

**stumpf/blunt/roma/mousse/smussa**

1,0 mm	12 cm	80-925-12-04
--------	-------	--------------

**stumpf/blunt/roma/mousse/smussa**

1,2 mm	16 cm	80-925-16-04
1,2 mm	18 cm	80-925-18-04
1,2 mm	20 cm	80-925-20-04
1,2 mm	22 cm	80-925-22-04

**stumpf/blunt/roma/mousse/smussa**

2,0 mm	16 cm	80-935-16-04
2,0 mm	18 cm	80-935-18-04
2,0 mm	20 cm	80-935-20-04
2,0 mm	22 cm	80-935-22-04
2,0 mm	24 cm	80-935-24-04

max. 500 V<sub>p</sub>



Beispielabbildung  
 Example illustration  
 Ilustración a modo de ejemplo  
 Illustration à titre d'exemple  
 Figura di esempio

**Bipolare Pinzetten, bajonettförmig**  
**Bipolar forceps, bayonet-shaped**  
**Pinzas bipolares, bayoneta**  
**Pincers bipolaires à baïonnette**  
**Pinze bipolari, baionetta**

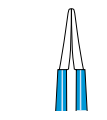

0,3 mm

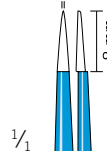

1,2 mm

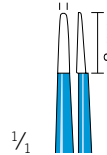

2,0 mm

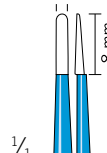

Spitzenbreite Tip width Ancho de la punta Largeur des pointes Larghezza delle punte	Länge Length Longitud Longueur Lunghezza	Artikel-Nr. Item No. N.º referencia Référence Codice articolo
---	--	---

**spitz/pointed/puntiaguda/pointue/acuta**

0,3 mm	16 cm	80-931-16-04
0,3 mm	18 cm	80-931-18-04
0,3 mm	20 cm	80-931-20-04
0,3 mm	24 cm	80-931-24-04

**stumpf/blunt/roma/mousse/smussa**

1,2 mm	16 cm	80-945-16-04
1,2 mm	18 cm	80-945-18-04
1,2 mm	20 cm	80-945-20-04
1,2 mm	24 cm	80-945-24-04

**stumpf/blunt/roma/mousse/smussa**

2,0 mm	18 cm	80-948-18-04
2,0 mm	20 cm	80-948-20-04
2,0 mm	24 cm	80-948-24-04
2,0 mm	30 cm	80-948-30-04



max. 500 V<sub>p</sub>

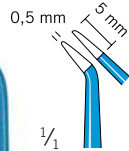
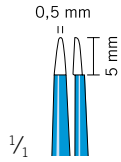

1/1

80-950-20-04  
 20 cm



1/1

80-951-20-04  
 20 cm

Geräte Units Equipos Appareils Apparecchi	Instrumente Instruments Instrumentos Strumenti	Europäischer Flachstecker, rund European flat plug, round Enchufe plano para Europa, redondo Fiche plate européenne, ronde Spina piatta europea, rotonda	
		max. 600 V <sub>p</sub>	max. 850 V <sub>p</sub>
KLS Martin Berchtold Aesculap		80-287-33-04 3 m	80-291-40-04 4 m
		80-287-53-04 5 m	
maXium® e Erbe ICC Erbe ACC Erbe VIO		80-286-30-04 3 m	80-286-40-04 4 m
		80-286-50-04 5 m	
maXium® i maXium® e ME MB 2 i ME MB 3 i Valleylab		80-287-89-04 3 m	80-293-40-04 4 m
		80-287-90-04 5 m	
Codman Valleylab		80-287-72-04 5 m	



mit geradem Stecker  
 with straight plug  
 con clavija recta  
 avec fiche droite  
 con spina diritta

mit abgewinkeltem Stecker  
 with angled plug  
 con clavija acodada  
 avec fiche coudée  
 con spina piegata

### Modellvielfalt

Alle gängigen Abmessungen für unterschiedliche Anwendungen

### Variety of models

All common dimensions for different applications

### Diversidad de modelos

Todas las dimensiones habituales para diferentes aplicaciones

### De nombreux modèles

Toutes les dimensions courantes pour applications diverses

### Molteplicità di modelli

Tutte le dimensioni di uso comune per le diverse applicazioni

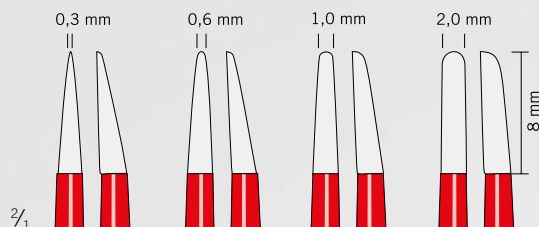

### Pinzettenspitzen

- Die Pinzettenspitzen aus Silber verhindern ein Anhaften von Gewebe
- Optimale Wärmeleitfähigkeit

### The tips of the forceps

- The silver forceps tips prevent tissue from sticking
- Optimum thermal conductivity

### Las puntas de la pinza

- Las puntas de plata de las pinzas evitan la adhesión de tejidos
- Conductividad térmica óptima

### Pointes de la pince

- Les extrémités des pincés en argent préviennent toute adhérence de tissu
- Conductivité thermique optimale

### Punte delle pinze

- Le punte delle pinze in argento prevengono l'adesione di tessuti
- Massima conducibilità termica



### marSIGHT-Geometrie

- Maximale Sicht auf das OP-Feld
- Punktgenaues Fassen von Gewebe

### marSIGHT geometry

- Maximum view of the surgical site
- High-precision grasping of tissue

### Geometría marSIGHT

- Visibilidad máxima sobre el campo operatorio
- Aprisionado del tejido con precisión puntual

### Géométrie marSIGHT

- Visibilité maximale sur le champ opératoire
- Saisie ponctuelle de tissu

### Geometria marSIGHT

- Massima visibilità dal campo operatorio
- Afferraggio di alta precisione del tessuto







## revolutionary ergonomic design



- Integrierte Pinzettenführung
- Integrated guiding mechanism
- Mecanismo de guiado integrado
- Mécanisme de guidage intégré
- Meccanismo di guida integrato

4



- Europäischer Flachpin-Stecker
- European flat-pin plug
- Clavija europea de pin plano
- Fiche européenne à broche plate
- Spina europea a pin piatto



- Ergonomische Grifffläche für ermüdungsfreies Arbeiten
- Ergonomic handle surface prevents fatigue in the surgeon's hand
- La superficie ergonómica del mango evita la fatiga en la mano del cirujano
- Surface de la poignée ergonomique pour un travail sans fatigue
- Superficie ergonomica dell'impugnatura per lavorare senza fatica

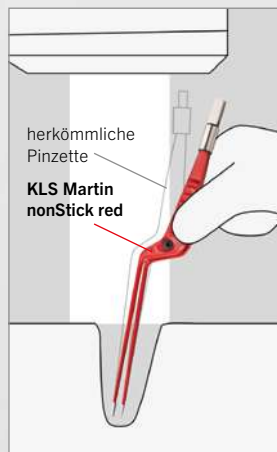

- Sichtoptimierte Schenkelgeometrie für die Anwendung unter dem OP-Mikroskop
- View-optimized shank geometry for applications under the operating microscope
- Geometría optimizada de las ramas en pro de la visibilidad para la aplicación bajo el microscopio quirúrgico
- Géométrie des branches optimisée pour une visibilité accrue sous le microscope opératoire
- Geometria delle branche a visibilità perfezionata per applicazione sotto il microscopio operatorio

Bipolare Pinzetten, nonStick red  
 Bipolar forceps, nonStick red  
 Pinzas bipolares, nonStick red  
 Pincas bipolaires, nonStick red  
 Pinze bipolarari, nonStick red

**nonStick** red

revolutionary  
 ergonomic  
 design

max. 500 V<sub>p</sub>



Bipolare Pinzetten, gerade  
 Bipolar forceps, straight  
 Pinzas bipolares, rectas  
 Pincas bipolaires, droites  
 Pinze bipolarari, diritte

	Spitzenbreite Tip width Ancho de la punta Largeur des pointes Larghezza delle punte	Länge Length Longitud Longueur Lunghezza	Artikel-Nr. Item No. N.º referencia Référence Codice articolo
<b>marSIGHT</b>			
0,3 mm			
$\frac{2}{1}$		8 mm	<b>spitz/pointed/puntiaguda/pointue/acuta</b>
			0,3 mm 12 cm 80-982-12-04
			0,3 mm 17 cm 80-982-17-04
			0,3 mm 20 cm 80-982-20-04
<b>marSIGHT</b>			
0,6 mm			
$\frac{2}{1}$		8 mm	<b>stumpf/blunt/roma/mousse/smussa</b>
			0,6 mm 12 cm 80-984-12-04
			0,6 mm 17 cm 80-984-17-04
			0,6 mm 20 cm 80-984-20-04
<b>Standard</b>			
1,0 mm			
$\frac{2}{1}$		8 mm	<b>stumpf/blunt/roma/mousse/smussa</b>
			1,0 mm 12 cm 80-986-12-04
			1,0 mm 17 cm 80-986-17-04
			1,0 mm 20 cm 80-986-20-04
			1,0 mm 23 cm 80-986-23-04
<b>Standard</b>			
2,0 mm			
$\frac{2}{1}$		8 mm	<b>stumpf/blunt/roma/mousse/smussa</b>
			2,0 mm 17 cm 80-988-17-04
			2,0 mm 20 cm 80-988-20-04
			2,0 mm 23 cm 80-988-23-04
			2,0 mm 30 cm 80-988-30-04

80-982-12-04  
 12 cm  
 spitz, 0,3 mm  
 pointed, 0,3 mm  
 puntiaguda, 0,3 mm  
 pointue, 0,3 mm  
 acuta, 0,3 mm

Beispielabbildung  
 Example illustration  
 Ilustración a modo de ejemplo  
 Illustration à titre d'exemple  
 Figura di esempio



max. 500 V<sub>p</sub>



**Bipolare Pinzetten, gewinkelt**  
**Bipolar forceps, angled**  
**Pinzas bipolares, acodadas**  
**Pinces bipolaires, coudées**  
**Pinze bipolarari, piegate**

**Standard**

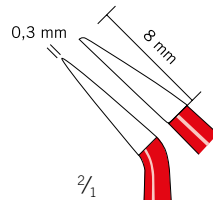

**Standard**

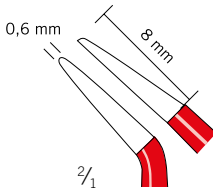

**Standard**

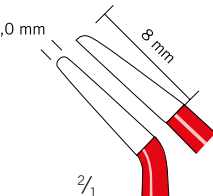

**Standard**

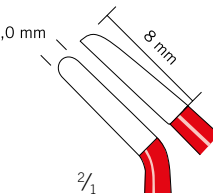

Spitzenbreite Tip width Ancho de la punta Largeur des pointes Larghezza delle punte	Länge Length Longitud Longueur Lunghezza	Artikel-Nr. Item No. N.º referencia Référence Codice articolo
---	--	---

**spitz/pointed/puntiaguda/pointue/acuta**

0,3 mm	12 cm	80-983-12-04
0,3 mm	17 cm	80-983-17-04

**stumpf/blunt/roma/mousse/smussa**

0,6 mm	12 cm	80-985-12-04
0,6 mm	17 cm	80-985-17-04
0,6 mm	20 cm	80-985-20-04

**stumpf/blunt/roma/mousse/smussa**

1,0 mm	12 cm	80-987-12-04
1,0 mm	17 cm	80-987-17-04
1,0 mm	20 cm	80-987-20-04
1,0 mm	23 cm	80-987-23-04

**stumpf/blunt/roma/mousse/smussa**

2,0 mm	17 cm	80-989-17-04
2,0 mm	20 cm	80-989-20-04
2,0 mm	23 cm	80-989-23-04
2,0 mm	25 cm	80-989-25-04
2,0 mm	28 cm	80-989-28-04
2,0 mm	30 cm	80-989-30-04

80-983-12-04  
 12 cm  
 spitz, 0,3 mm  
 pointed, 0,3 mm  
 puntiaguda, 0,3 mm  
 pointue, 0,3 mm  
 acuta, 0,3 mm

Beispielabbildung  
 Example illustration  
 Ilustración a modo de ejemplo  
 Illustration à titre d'exemple  
 Figura di esempio

Bipolare Pinzetten, nonStick red  
 Bipolar forceps, nonStick red  
 Pinzas bipolares, nonStick red  
 Pincès bipolaires, nonStick red  
 Pinze bipolari, nonStick red

**nonStick** red

revolutionary  
 ergonomic  
 design

max. 500 V<sub>p</sub>



1/1

Beispielabbildung  
 Example illustration  
 Ilustración a modo de ejemplo  
 Illustration à titre d'exemple  
 Figura di esempio

Bipolare Pinzetten, bajonettförmig  
 Bipolar forceps, bayonet-shaped  
 Pinzas bipolares, bayoneta  
 Pincès bipolaires, à baïonnette  
 Pinze bipolari, baionetta

	Spitzenbreite Tip width Ancho de la punta Largeur des pointes Larghezza delle punte	Länge Length Longitud Longueur Lunghezza	Artikel-Nr. Item No. N.º referencia Référence Codice articolo
<b>marSIGHT</b> 	<b>spitz/pointed/puntiaguda/pointue/acuta</b>		
	0,3 mm	17 cm	80-990-17-04
	0,3 mm	20 cm	80-990-20-04
	0,3 mm	23 cm	80-990-23-04
	0,3 mm	25 cm	80-990-25-04
<b>marSIGHT</b> 	<b>stumpf/blunt/roma/mousse/smussa</b>		
	0,6 mm	17 cm	80-991-17-04
	0,6 mm	20 cm	80-991-20-04
	0,6 mm	23 cm	80-991-23-04
	0,6 mm	25 cm	80-991-25-04
<b>Standard</b> 	<b>stumpf/blunt/roma/mousse/smussa</b>		
	1,0 mm	17 cm	80-992-17-04
	1,0 mm	20 cm	80-992-20-04
	1,0 mm	23 cm	80-992-23-04
	1,0 mm	25 cm	80-992-25-04
<b>Standard</b> 	<b>stumpf/blunt/roma/mousse/smussa</b>		
	2,0 mm	17 cm	80-993-17-04
	2,0 mm	20 cm	80-993-20-04
	2,0 mm	23 cm	80-993-23-04
	2,0 mm	25 cm	80-993-25-04

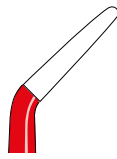

nach oben gewinkelt  
 upward-bent  
 acodada hacia arriba  
 coudée vers le haut  
 piegata in alto

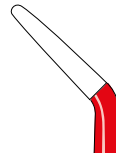

nach unten gewinkelt  
 downward-bent  
 acodada hacia abajo  
 coudée vers le bas  
 piegata in basso

**Bipolare Pinzetten, bajonettförmig, gewinkelt**  
**Bipolar forceps, bayonet-shaped, angled**  
**Pinzas bipolares, bayoneta, acodadas**  
**Pinces bipolaires, à baïonnette, coudées**  
**Pinze bipolarari, baionetta, piegate**

Standard

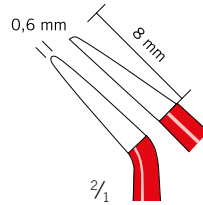

Spitzenbreite Tip width Ancho de la punta Largeur des pointes Larghezza delle punte	Länge Length Longitud Longueur Lunghezza	Artikel-Nr. Item No. N.º referencia Référence Codice articolo
---	--	---

**stumpf/blunt/roma/mousse/smussa**

0,6 mm	23 cm	80-997-23-04
0,6 mm	25 cm	80-997-25-04

Standard

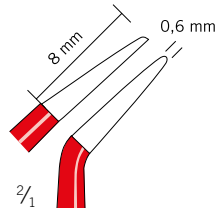

**stumpf/blunt/roma/mousse/smussa**

0,6 mm	23 cm	80-996-23-04
0,6 mm	25 cm	80-996-25-04

Standard

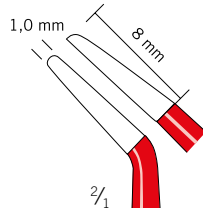

**stumpf/blunt/roma/mousse/smussa**

1,0 mm	20 cm	80-994-20-04
1,0 mm	23 cm	80-994-23-04
1,0 mm	25 cm	80-994-25-04

Standard

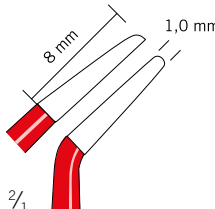

**stumpf/blunt/roma/mousse/smussa**

1,0 mm	20 cm	80-995-20-04
1,0 mm	23 cm	80-995-23-04

Beispielabbildung  
 Example illustration  
 Ilustración a modo de ejemplo  
 Illustration à titre d'exemple  
 Figura di esempio

Bipolare Pinzetten, nonStick red, gebogen  
 Bipolar forceps, nonStick red, curved  
 Pinzas bipolares, nonStick red, acodadas  
 Pincès bipolaires, nonStick red, courbes  
 Pinze bipolari, nonStick red, curve

**nonStick** red

max. 500 V<sub>p</sub>



1/1

1/1

1/1

1/1









80-998-23-04  
23 cm

80-999-23-04  
23 cm

80-999-24-04  
23 cm

Meuser  
80-998-24-04  
18 cm



<p><b>Instrumente</b>  <b>Instruments</b>  <b>Instrumentos</b>  <b>Strumenti</b></p> <p><b>Geräte</b>  <b>Units</b>  <b>Equipos</b>  <b>Appareils</b>  <b>Apparecchi</b></p>	<p>Europäischer Flachstecker, rund                      European flat plug, round                      Enchufe plano para Europa, redondo                      Fiche plate européenne, ronde                      Spina piatta europea, rotonda</p> <p><b>max. 600 V<sub>p</sub></b>      <b>max. 850 V<sub>p</sub></b></p> 
<p>KLS Martin                      Berchtold                      Aesculap</p>  	<p>1/3</p> <p>80-287-33-04 3 m      80-291-40-04 4 m</p> <p>80-287-53-04 5 m</p>
<p>maXium® e                      Erbe ICC                      Erbe ACC                      Erbe VIO</p>  	<p>80-286-30-04 3 m      80-286-40-04 4 m</p> <p>80-286-50-04 5 m</p>
<p>maXium® i                      maXium® e                      ME MB 2 i                      ME MB 3 i                      Valleylab</p>  	<p>80-287-89-04 3 m      80-293-40-04 4 m</p> <p>80-287-90-04 5 m</p>
<p>Codman                      Valleylab</p>  	<p>80-287-72-04 5 m</p>



mit geradem Stecker  
 with straight plug  
 con clavija recta  
 avec fiche droite  
 con spina diritta



mit abgewinkeltem Stecker  
 with angled plug  
 con clavija acodada  
 avec fiche coudée  
 con spina piegata



Weitere Informationen entnehmen Sie bitte der separaten Broschüre.

For further information please refer to our separate product brochure.

Encontrará informaciones adicionales en el folleto individual.

Vous trouverez des informations supplémentaires dans la brochure.

Per ulteriori informazioni vedasi il prospetto separato.

Bipolare Pinzetten, nonStick red  
 Bipolar forceps, nonStick red  
 Pinzas bipolares, nonStick red  
 Pincas bipolaires, nonStick red  
 Pinze bipolari, nonStick red

**nonStick** red

### Lagerung und Transport

Für die sichere Lagerung und den Transport der bipolaren nonStick-red-Pinzetten kann das neue Siebkorbssystem von KLS Martin verwendet werden.

### Storage and transport

To store and transport your nonStick red forceps safely and securely, we recommend using the new KLS Martin mesh tray system.

### Almacenaje y transporte

Para el almacenaje y transporte seguros de las pinzas bipolares nonStick red puede utilizarse el nuevo sistema de bandejas cribadas de KLS Martin.

### Stockage et transport

Le nouveau système de paniers à mailles de KLS Martin garantit la fiabilité des stockage et transport des pinces bipolaires nonStick red.

### Magazzinaggio e trasporto

Per il magazzinaggio e trasporto sicuri delle pinze bipolari nonStick red è possibile usare il nuovo sistema di vassoi reticolati di KLS Martin.



	Für Pinzetten mit einer maximalen Länge von 23 cm schlagen wir folgende Konfiguration vor:		For forceps with a maximum length of 23 cm, we recommend the following configuration:		Para pinzas con una longitud máxima de 23 cm proponemos la siguiente configuración:	
	Artikelbeschreibung	Menge	Designation	Quantity	Descripción del artículo	Cantidad
55-804-25-01	Siebkorb, 243 x 255 x 53 mm	1	Mesh tray, 243 x 255 x 53 mm	1	Bandeja cribada, 243 x 255 x 53 mm	1
55-805-28-01	Deckel, 243 x 255 mm	1	Lid, 243 x 255 mm	1	Tapa, 243 x 255 mm	1
	<b>Fixierelemente</b>		<b>Fixing elements</b>		<b>Elementos de fijación</b>	
55-806-02-04	Clip für Fixierelement (VE = 10 Stück)	1	Clip for fixing element (10/pack)	1	Clip para elemento de fijación (UE = 10 ud.)	1
55-806-07-04	Fixierelement (VE = 6 Stück)	2	Fixing element (6/pack)	2	Elemento de fijación (UE = 6 ud.)	2

	Für Pinzetten größer 23 cm sollte ein ¾-Siebkorb verwendet werden:		For forceps longer than 23 cm, a ¾-size tray should be used.		For forceps longer than 23 cm, a ¾-size tray should be used.	
	Artikelbeschreibung	Menge	Designation	Quantity	Descripción del artículo	Cantidad
55-804-42-01	Siebkorb, 410 x 255 x 53 mm	1	Mesh tray, 410 x 255 x 53 mm	1	Mesh tray, 410 x 255 x 53 mm	1
55-805-45-01	Deckel, 410 x 255 mm	1	Lid, 410 x 255 mm	1	Lid, 410 x 255 mm	1
	<b>Fixierelemente</b>		<b>Fixing elements</b>		<b>Elementos de fijación</b>	
55-806-02-04	Clip für Fixierelement (VE = 10 Stück)	1	Clip for fixing element (10/pack)	1	Clip for fixing element (10/pack)	1
55-806-07-04	Fixierelement (VE = 6 Stück)	2	Fixing element (6/pack)	2	Fixing element (6/pack)	2

	Menge	Designation	Quantity	Descripción del artículo	Cantidad
55-804-19-01	marTray®, mini 277 x 84 x 36 mm	1	marTray®, mini 277 x 84 x 36 mm	1	marTray®, mini 277 x 84 x 36 mm





Beispiel Bestückung  
 Equipment example  
 Ejemplo de dotación  
 Exemple chargement  
 Esempio di allestimento



Fixierelemente werden in zusammenhängenden 6er-Einheiten mit drei Halteclips geliefert. Sie können jedoch problemlos mit einer Schere die Einheit trennen – ganz wie Sie es brauchen.

Fixing elements are available as 6-item strips with three holding clips. However, you can easily cut up the strips with a pair of scissors – just as you need it.

Los elementos de fijación se suministran en unidades continuas de 6 con tres clips de sujeción. No obstante, usted también puede separar sin problemas la unidad de 6 con unas tijeras, según sus requerimientos personales.

Les éléments de fixation sont livrés par unités de 6 d'un seul tenant, avec trois clips. Il vous suffit de découper ces éléments de fixation avec une paire de ciseaux – en fonction de vos besoins.

Gli elementi di fissaggio vengono forniti in confezioni di sei unità con tre clip. Potete però tagliare l'unità con un paio di forbici in base alle vostre esigenze.



55-804-19-01

4

	Nous proposons la configuration suivante pour les pinces de 23 cm de long au maximum:		Per pinze della lunghezza massima di 23 cm proponiamo la seguente configurazione:	
	<b>Description</b>	<b>Quantité</b>	<b>Designazione</b>	<b>Quantità</b>
55-804-25-01	Panier à mailles, 243 x 255 x 53 mm	1	Vassoio reticolato, 243 x 255 x 53 mm	1
55-805-28-01	Couvercle, 243 x 255 mm	1	Coperchio, 243 x 255 mm	1
	<b>Éléments de fixation</b>		<b>Elementi di fissaggio</b>	
55-806-02-04	Clip pour élément de fixation (UE = 10)	1	Clip per elemento di fissaggio (UV=10 pezzi)	1
55-806-07-04	Élément de fixation (UE = 6)	2	Elemento di fissaggio (UV=6 pezzi)	2

	Il est recommandé d'utiliser une panier à mailles ¾ pour les pinces de plus de 23 cm de long:		Per pinze di lunghezza superiore a 23 cm si consiglia di usare un vassoio di grandezza ¾:	
	<b>Description</b>	<b>Quantité</b>	<b>Designazione</b>	<b>Quantità</b>
55-804-42-01	Panier à mailles, 410 x 255 x 53 mm	1	Vassoio reticolato, 410 x 255 x 53 mm	1
55-805-45-01	Couvercle, 410 x 255 mm	1	Coperchio, 410 x 255 mm	1
	<b>Éléments de fixation</b>		<b>Elementi di fissaggio</b>	
55-806-02-04	Clip pour élément de fixation (UE = 10)	1	Clip per elemento di fissaggio (UV=10 pezzi)	1
55-806-07-04	Élément de fixation (UE = 6)	2	Elemento di fissaggio (UV=6 pezzi)	2

	<b>Description</b>	<b>Quantité</b>	<b>Designazione</b>	<b>Quantità</b>
55-804-19-01	marTray®, mini 277 x 84 x 36 mm	1	marTray®, mini 277 x 84 x 36 mm	1

Bipolare Spülpinzetten, nonStick flush  
Bipolar irrigation forceps, nonStick flush  
Pinzas bipolares con función de enjuague, nonStick flush  
Pinces d'irrigation bipolaires, nonStick flush  
Pinze bipolari con irrigazione, nonStick flush

**nonStick** flush

### Modellvielfalt

Alle gängigen Abmessungen für unterschiedliche Anwendungen

### Variety of models

All common dimensions for different applications

### Diversidad de modelos

Todas las dimensiones habituales para diferentes aplicaciones

### De nombreux modèles

Toutes les dimensions courantes pour applications diverses

### Molteplicità di modelli

Tutte le dimensioni di uso comune per le diverse applicazioni

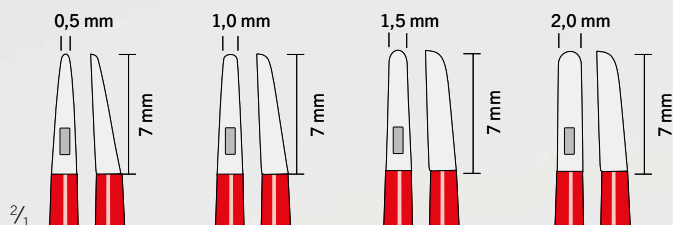

### Pinzettenspitzen

- Die Spülöffnung befindet sich direkt auf der Fassfläche

### The tips of the forceps

- The irrigation opening is located right on the gripping surfaces

### Las puntas de la pinza

- La abertura se encuentra directamente en la superficie de sujeción

### Pointes de la pince

- L'orifice d'irrigation se trouve directement sur la surface de saisie

### Punte delle pinze

- L'orificio di irrigazione si trova direttamente sulla superficie di presa





- Integration des Spülkanals in den Schenkel
- Integration of the irrigation channel in the handle
- Integración del canal de irrigación en la rama
- Intégration du canal d'irrigation dans la branche
- Integrazione del canale di irrigazione nella branca
- Zufuhr der Spülflüssigkeit über Luer-Lock-Anschluss
- The irrigation fluid is supplied via the Luer Lock connection
- La alimentación del líquido se realiza a través de un conector Luer-Lock
- Le liquide d'irrigation est amené via le raccord Luer-Lock
- L'apporto del liquido di irrigazione avviene mediante il raccordo Luer-Lock



- Europäischer Flachpin-Stecker
- European flat-pin plug
- Clavija europea de pin plano
- Fiche européenne à broche plate
- Spina europea a pin piatto



- Präzise Führung der Pinzettenspitzen
- Precision guidance of forceps tips
- Guiado preciso de las puntas de las pinzas
- Les pointes de la pince sont guidées avec précision
- Meccanismo di guida precisa delle punte delle pinze

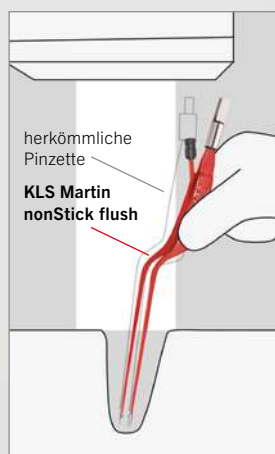

- Sichtoptimierte Schenkelgeometrie für die Anwendung unter dem OP-Mikroskop
- View-optimized shank geometry for applications under the operating microscope
- Geometría optimizada de las ramas en pro de la visibilidad para la aplicación bajo el microscopio quirúrgico
- Géométrie des branches optimisée pour une visibilité accrue sous le microscope opératoire
- Geometria delle branche a visibilità perfezionata per applicazione sotto il microscopio operatorio

max. 500 V<sub>p</sub>



$\frac{2}{1}$

Beispielabbildung  
 Example illustration  
 Ilustración a modo de ejemplo  
 Illustration à titre d'exemple  
 Figura di esempio

Bipolare Pinzetten, bajonettförmig, mit *einseitiger* Spülung  
 Bipolar forceps, bayonet-shaped with irrigation *on one side*  
 Pinzas bipolares, bayoneta, con función de enjuague *unilateral*  
 Pincas bipolaires, à baïonnette, avec irrigation *unilatérale*  
 Pinze bipolari, a baionetta, con irrigazione *unilaterale*

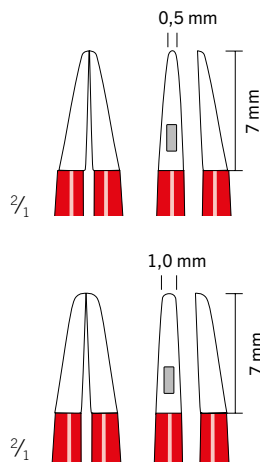

Spitzenbreite Tip width Ancho de la punta Largeur des pointes Larghezza delle punte	Länge Length Longitud Longueur Lunghezza	Artikel-Nr. Item No. N.º referencia Référence Codice articolo
---	--	---

**stumpf/blunt/roma/mousse/smussa**

0.5 x 7 mm	20 cm	80-981-01-04
------------	-------	--------------

0.5 x 7 mm	23 cm	80-981-03-04
------------	-------	--------------

**stumpf/blunt/roma/mousse/smussa**

1.0 x 7 mm	20 cm	80-981-02-04
------------	-------	--------------

1.0 x 7 mm	23 cm	80-981-04-04
------------	-------	--------------

$\frac{2}{1}$

Zubehör  
 Accessories  
 Accesorios  
 Accessoires  
 Accessori

80-981-07-04

Set Reinigungsbürsten, 5 Stück

Im Lieferumfang der Pinzetten sind bereits Reinigungsbürsten enthalten.

Cleaning brush set, 5 qty.

Cleaning brushes are included in delivery with the forceps.

Juego de cepillos de limpieza, 5 unidades

Las prestaciones del suministro de la pinza ya incluyen cepillos de limpieza.

Set de brosses de nettoyage, 5 pièces

Plusieurs brosses de nettoyage sont d'ores et déjà comprises dans l'étendue de livraison des pincas.

Set di spazzole di pulitura, 5 pezzi

Nella fornitura sono già comprese le spazzole di pulitura.

Bipolare Spülpinzetten, nonStick flush  
 Bipolar irrigation forceps, nonStick flush  
 Pinzas bipolares con función de enjuague, nonStick flush  
 Pincas d'irrigation bipolaires, nonStick flush  
 Pinze bipolari con irrigazione, nonStick flush

Bipolares Zubehör  
 Bipolar accessories  
 Accesorios bipolares  
 Accessoires bipolaires  
 Accessori bipolari



max. 500 V<sub>p</sub>



**Bipolare Pinzetten, gerade, mit einseitiger Spülung**  
**Bipolar forceps, straight, with irrigation on one side**  
**Pinzas bipolares, rectas, con función de enjuague unilateral**  
**Pincas bipolaires, droites, avec irrigation unilatérale**  
**Pinze bipolari, diritte, con irrigazione unilaterale**

Spitzenbreite Tip width Ancho de la punta Largeur des pointes Larghezza delle punte	Länge Length Longitud Longueur Lunghezza	Artikel-Nr. Item No. N.º referencia Référence Codice articolo
stumpf/blunt/roma/mousse/smussa		
1.5 x 7 mm	20 cm	80-981-05-04

**Bipolare Pinzetten, gerade, mit beidseitiger Spülung**  
**Bipolar forceps, straight, with irrigation on both sides**  
**Pinzas bipolares, rectas, con función de enjuague bilateral**  
**Pincas bipolaires, droites, avec irrigation bilatérale**  
**Pinze bipolari, diritte, con irrigazione bilaterale**

Spitzenbreite Tip width Ancho de la punta Largeur des pointes Larghezza delle punte	Länge Length Longitud Longueur Lunghezza	Artikel-Nr. Item No. N.º referencia Référence Codice articolo
stumpf/blunt/roma/mousse/smussa		
2.0 x 7 mm	23 cm	80-981-06-04
2.0 x 7 mm	30 cm	80-981-08-04

**Anwendungsbeispiele:**

- Viszeralchirurgie
- Leberchirurgie

**Application examples:**

- Visceral surgery
- Liver surgery

**Ejemplos de aplicación:**

- Cirugía visceral
- Cirugía hígado

**Exemples d'applications:**

- Chirurgie viscérale
- Chirurgie du foie

**Esempi di applicazione:**

- Chirurgia viscerale
- Chirurgia fegato



Beispielabbildung  
 Example illustration  
 Ilustración a modo de ejemplo  
 Illustration à titre d'exemple  
 Figura di esempio

Beispielabbildung  
 Example illustration  
 Ilustración a modo de ejemplo  
 Illustration à titre d'exemple  
 Figura di esempio

## maXium<sup>®</sup>, maXium<sup>®</sup> smart C and nonStick flush

EHT – eine wirksame nonStick-Methode in der Elektrochirurgie

EHT – an effective nonStick method in electro-surgery

EHT – un método nonStick eficaz en electrocirugía

EHT – une méthode nonStick efficace en électrochirurgie

EHT – un efficace metodo nonStick in elettrochirurgia



Neptun



Neptun  
Auto-Start



Die bipolare Stromart „Neptun“ des HF-Generators maXium<sup>®</sup> wurde speziell für die flüssigkeitsunterstützte HF-Koagulation entwickelt (**EHT = Elektrohydrothermosation**). Diese Methode hat sich speziell bei Anwendungen in der Viszeral- und Neurochirurgie bewährt. Die bipolare Koagulation erfolgt indirekt über die erhitzte isotonische Kochsalzlösung. Die Stromart ist an die Bedürfnisse der bipolaren Spülpinzetten nonStick flush angepasst.

**Natürlich sind die nonStick-flush-Pinzetten auch mit den am Markt gängigen HF-Generatoren einsetzbar.**

The "Neptun" current type of the maXium<sup>®</sup> HF generator was developed specifically for fluid-assisted HF coagulation (**EHT = electrohydrothermosation**). This method has been well proven, especially in abdominal and neurosurgery applications. Bipolar coagulation is carried out indirectly via the heated isotonic saline solution. The type of current is adapted to the requirements of the nonStick flush bipolar irrigation forceps.

**The nonStick flush forceps can naturally also be used with currently available HF generators.**

El tipo de corriente bipolar "Neptun" del generador de AF maXium<sup>®</sup> ha sido especialmente desarrollado para la coagulación de AF asistida por líquido (**EHT = electrohydrothermosation**). Este método se ha acreditado especialmente en aplicaciones de la cirugía visceral y la neurocirugía. La coagulación se realiza indirectamente a través del suero fisiológico isotónico caliente. Este tipo de corriente está adaptado a los requerimientos de la pinza bipolar con función de enjuague nonStick flush.

**Naturalmente, las pinzas nonStick flush también pueden utilizarse con los generadores de AF habituales del mercado.**









Le type de courant bipolaire «Neptun» du générateur HF maXium<sup>®</sup> a été spécialement conçu pour la coagulation HF assistée par liquide (**EHT = electrohydrothermosation**). Cette méthode a fait notamment ses preuves dans les applications en chirurgie viscérale et en neurochirurgie. La coagulation bipolaire s'effectue indirectement via la solution isotonique de chlorure de sodium chauffée. Ce type de courant est adapté aux exigences des pinces d'irrigation bipolaires nonStick flush.

**Il va de soi que les pinces nonStick flush peuvent également être employées avec les générateurs HF que l'on trouve couramment sur le marché.**

Il tipo di corrente bipolare "Neptun" del generatore AF maXium<sup>®</sup> è stato realizzato appositamente per la coagulazione AF liquido-assistita (EHT = electrohydrothermosation). Questo metodo ha dimostrato la propria efficacia soprattutto in applicazioni di chirurgia viscerale e neurologica. La coagulazione bipolare avviene indirettamente sulla soluzione fisiologica isotonica riscaldata. Questo tipo di corrente è adattato ai requisiti delle pinze bipolari con irrigazione nonStick flush.

**Naturalmente le pinze nonStick flush possono essere utilizzate anche con i generatori AF comunemente in commercio.**



<p><b>Geräte</b>  <b>Units</b>  <b>Equipos</b>  <b>Appareils</b>  <b>Apparecchi</b></p>	<p><b>Instrumente</b>  <b>Instruments</b>  <b>Instrumentos</b>  <b>Strumenti</b></p>	<p>Europäischer Flachstecker, rund                      European flat plug, round                      Enchufe plano para Europa, redondo                      Fiche plate européenne, ronde                      Spina piatta europea, rotonda</p> <p><b>max. 600 V<sub>p</sub></b>      <b>max. 850 V<sub>p</sub></b></p>  	
<p>KLS Martin                      Berchtold                      Aesculap</p>  		<p>80-287-33-04                      3 m</p> <p>80-287-53-04                      5 m</p>	<p>80-291-40-04                      4 m</p>
<p>maXium® e                      Erbe ICC                      Erbe ACC                      Erbe VIO</p>  		<p>80-286-30-04                      3 m</p> <p>80-286-50-04                      5 m</p>	<p>80-286-40-04                      4 m</p>
<p>maXium® i                      maXium® e                      ME MB 2 i                      ME MB 3 i                      Valleylab</p>  		<p>80-287-89-04                      3 m</p> <p>80-287-90-04                      5 m</p>	<p>80-293-40-04                      4 m</p>



mit geradem Stecker  
 with straight plug  
 con clavija recta  
 avec fiche droite  
 con spina diritta



mit abgewinkeltem Stecker  
 with angled plug  
 con clavija acodada  
 avec fiche coudée  
 con spina piegata

Weitere Informationen entnehmen Sie bitte der separaten Broschüre sowie unseren Anwendungsberichten.

For further information please refer to our separate product brochure and our application reports.

Encontrará informaciones adicionales en el folleto individual y nuestros informes de aplicación.

Vous trouverez des informations supplémentaires dans la brochure et dans nos rapports d'application.

Per ulteriori informazioni vedasi il prospetto separato ed i nostri rapporti d'applicazione.

**Übersicht der Wechselelektroden**  
**Overview of exchangeable electrodes**  
**Resumen de los electrodos intercambiables**  
**Présentation des électrodes interchangeables**  
**Presentazione degli elettrodi intercambiabili**

**Arbeitslänge 34 cm**  
**Working length 34 cm**  
**Longitud de trabajo 34 cm**  
**Longueur d'utilisation 34 cm**  
**Lunghezza dell'uso 34 cm**

**max. 500 V<sub>p</sub>**



83-585-03-04

marLap® Cut

Scheren-Wechselelektrode, gebogen, 340 mm,  
zum mechanischen Schneiden bei gleichzeitiger Koagulation

Scissor-type exchangeable electrode, curved, 340 mm,  
for mechanical cutting and simultaneous coagulation

Electrodo intercambiable tipo tijeras, 340 mm,  
para el corte mecánico y coagulación simultánea

Électrode ciseaux interchangeable, 340 mm,  
pour la coupe mécanique avec coagulation simultanée

Elettrodo intercambiabile tipo forbici, 340 mm,  
per l'incisione meccanica in condizioni di coagulazione simultanea



83-585-05-04

marLap® Clamp

Fasszangen-Wechselelektrode, gefenestert, 340 mm,  
zur Versiegelung von Gefäßen und Gewebebündeln

Grasping forceps exchangeable electrode, fenestrated, 340 mm,  
for sealing vessels and tissue bundles

Electrodo intercambiable tipo pinza de secuestros, con ventana, 340 mm,  
para el sellado vascular y de haces de tejido

Électrode pince interchangeable, fenêtrée, 340 mm,  
pour le clampage des vaisseaux et des faisceaux de tissus

Elettrodo intercambiabile tipo clamp, con finestra, 340 mm,  
per la coagulazione di vasi e di fasci di tessuto



83-585-06-04

marLap® Maryland

Fasszangen-Wechselelektrode, gebogen, 340 mm,  
zum Präparieren und Koagulieren

"Grasping forceps" exchangeable electrode,  
curved, 340 mm, for dissecting and coagulating

Electrodo intercambiable tipo pinza de secuestros, acodado,  
340 mm, para diseccionar y coagular

Électrode pince interchangeable, courbe, 340 mm,  
pour la dissection et la coagulation

Elettrodo intercambiabile tipo clamp, versione curva, 340 mm,  
piegato, per le operazioni di preparazione e per  
la coagulazione



83-585-07-04

marLap® Clamp

Fasszangen-Wechselelektrode, ungenestert, glatt, 340 mm,  
zur Koagulation von Gefäßen und Gewebebündeln

Grasping forceps exchangeable electrode, non-fenestrated, smooth, 340 mm,  
for coagulating vessels and tissue bundles

Electrodo intercambiable tipo pinza de secuestros, no fenestrado, 340 mm,  
para el coagulación vascular y de haces de tejido

Électrode pince interchangeable, non fenêtrée, 340 mm,  
pour le coagulation des vaisseaux et des faisceaux de tissus

Elettrodo intercambiabile tipo clamp, senza finestra,  
liscio, 340 mm, per la coagulazione di vasi e  
di fasci di tessuto







max. 500 V<sub>p</sub>



83-585-01-04  
 Handgriff  
 Handle  
 Mango  
 Manche  
 Manico

83-585-02-04  
 Schaft  
 Shaft  
 Vástago  
 Tige  
 Asta

83-585-00-04  
 marLap® 340 mm, Ø 5 mm  
 Handgriff mit Schaft  
 Handle with shaft  
 Mango con vástago  
 Manche avec tige  
 Manico con asta

Weitere Informationen entnehmen Sie bitte der separaten Broschüre.

For further information please refer to our separate product brochure.

Encontrará informaciones adicionales en el folleto individual.

Vous trouverez des informations supplémentaires dans la brochure.

Per ulteriori informazioni vedasi il prospetto separato.



4



Geräte Units Equipos Appareils Apparecchi	Instrumente Instruments Instrumentos Strumenti	Europäischer Flachstecker, rund European flat plug, round Enchufe plano para Europa, redondo Fiche plate européenne, ronde Spina piatta europea, rotonda	
		max. 600 V <sub>p</sub>	max. 850 V <sub>p</sub>
KLS Martin Berchtold Aesculap		80-287-33-04 3 m	80-291-40-04 4 m
		80-287-53-04 5 m	
maXium® e Erbe ICC Erbe ACC Erbe VIO		80-286-30-04 3 m	80-286-40-04 4 m
		80-286-50-04 5 m	
maXium® i maXium® e ME MB 2 i ME MB 3 i Valleylab		80-287-89-04 3 m	80-293-40-04 4 m
		80-287-90-04 5 m	
Codman Valleylab		80-287-72-04 5 m	

Bipolare Elektroden für die Arthroskopie  
 Bipolar electrodes for arthroscopy  
 Electrodo bipolar para la artroscopia  
 Electrodes bipolaires pour arthroscopie  
 Elettrodi bipolari per artroscopia



- ✓ Ergonomisch    Ergonomic    Ergonómicos    Ergonomiques    Ergonomici
- ✓ Kompakt       Compact       Compactos       Compactes       Compatti
- ✓ Sicher         Safe         Seguros         Sûres         Sicuri



80-651-00-04 **max. 1000 V<sub>p</sub>**

Bipolare Hakenelektrode, Länge 115 mm, 0,6 mm  
 Bipolar hook electrode, length 115 mm, 0,6 mm  
 Electrodo bipolar de gancho, longitud 115 mm, 0,6 mm  
 Electrode à crochet bipolaire, longueur 115 mm, 0,6 mm  
 Elettrodo bipolare ad uncino, lunghezza 115 mm, 0,6 mm



80-652-00-04 **max. 1000 V<sub>p</sub>**

Bipolare Vaporisationselektrode „Phazer“, biegsam, inkl. Biegehilfe (80-652-01-04)  
 “Phazer” bipolar vaporization electrode, flexible, incl. bending device (80-652-01-04)  
 Electrodo de vaporización bipolar “Phazer”, flexible, incluye dispositivo de torsión (80-652-01-04)  
 Electrode de vaporisation bipolaire «Phazer», flexible, avec dispositif de pliage (80-652-01-04)  
 Elettrodo di vaporizzazione bipolare „Phazer“, flessibile, compreso dispositivo di curvatura (80-652-01-04)



**maXium®**

4

Weitere Informationen entnehmen Sie bitte der separaten Broschüre.  
 For further information please refer to our separate product brochure.  
 Encontrará informaciones adicionales en el folleto individual.  
 Vous trouverez des informations supplémentaires dans la brochure.  
 Per ulteriori informazioni vedasi il prospetto separato.



Schnittstelle Generator  
 Interface generator  
 Interfaz generador  
 Interface générateur  
 Interfaccia generatore

Schnittstelle Elektrode  
 Interface electrode  
 Interfaz electrodo  
 Interface électrode  
 Interfaccia elettrodo

1/3



80-288-70-04 **max. 700 V<sub>p</sub>**  
 3 m

Anschlusskabel für bipolare Elektroden, maXium® **m**  
 Connecting cable for bipolar electrodes, maXium® **m**  
 Cable de conexión para electrodos bipolares, maXium® **m**  
 Câble de raccordement pour électrodes bipolaires, maXium® **m**  
 Cavo di collegamento per elettrodi bipolari, maXium® **m**

Schnittstelle Generator  
 Interface generator  
 Interfaz generador  
 Interface générateur  
 Interfaccia generatore

Schnittstelle Elektrode  
 Interface electrode  
 Interfaz electrodo  
 Interface électrode  
 Interfaccia elettrodo

1/3

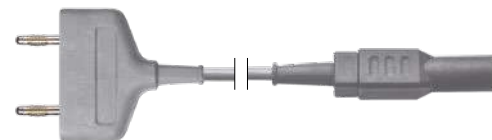

80-288-72-04 **max. 700 V<sub>p</sub>**  
 3 m

Anschlusskabel für bipolare Elektroden, maXium® **i/e**  
 Connecting cable for bipolar electrodes, maXium® **i/e**  
 Cable de conexión para electrodos bipolares, maXium® **i/e**  
 Câble de raccordement pour électrodes bipolaires, maXium® **i/e**  
 Cavo di collegamento per elettrodi bipolari, maXium® **i/e**

# 5

Instrumentarium zur bipolaren Gefäßversiegelung  
Instruments for bipolar vessel sealing  
Instrumentos para el sellado vascular bipolar  
Instruments pour la clampage vasculaire bipolaire  
Strumenti di sigillatura vascolare bipolare



Bipolare Klemmen für die Gefäßversiegelung  
 Bipolar forceps for vessel sealing  
 Pinzas bipolares para el sellado vascular  
 Pincès bipolaires pour le clampage vasculaire  
 Pinze bipolari per clampaggio vascolare

marClamp® IQ



✓ Präparieren	Dissect	Diseccionar	Disséquer	Sezionare
✓ Versiegeln	Seal	Sellar	Clamper	Sigillare
✓ <b>Plug &amp; Play</b>	<b>Plug &amp; Play</b>	<b>Plug &amp; Play</b>	<b>Plug &amp; Play</b>	<b>Plug &amp; Play</b>
✓ Wiederverwendbar	Reusable	Reutilizable	Réutilisable	Riutilizzabile



marClamp®, gebogene Version  
 marClamp®, curved version  
 marClamp®, versión curva  
 marClamp®, version courbe  
 marClamp®, versione curva

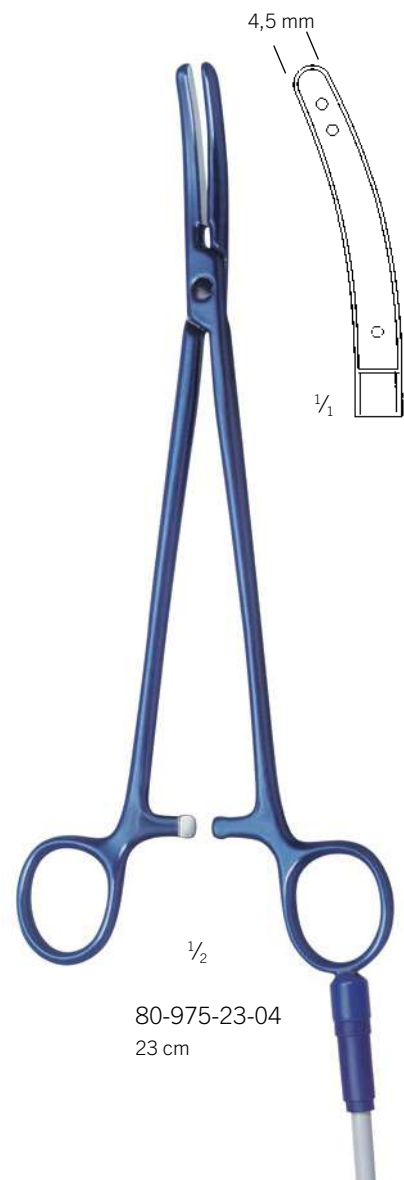
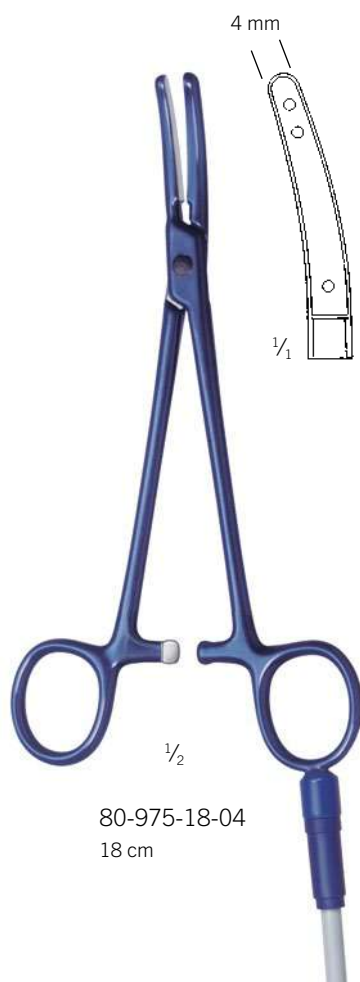

Instrumentarium zur bipolaren Gefäßversiegelung  
 Instruments for bipolar vessel sealing  
 Instrumentos para el sellado vascular bipolar  
 Instruments pour la clampage vasculaire bipolaire  
 Strumenti di sigillatura vascolare bipolare

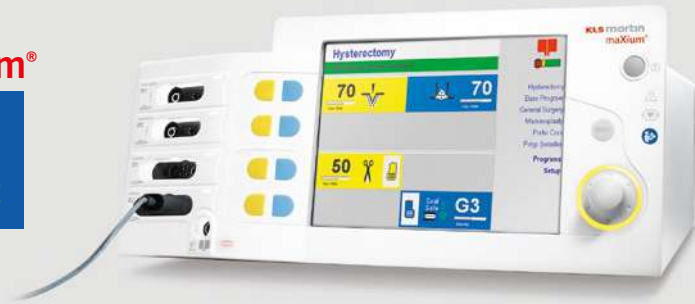

5

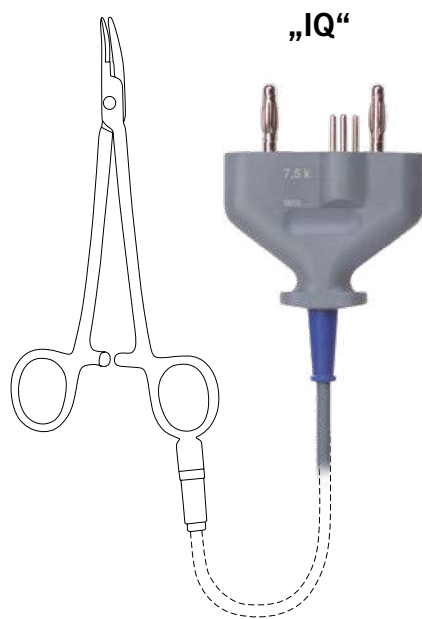
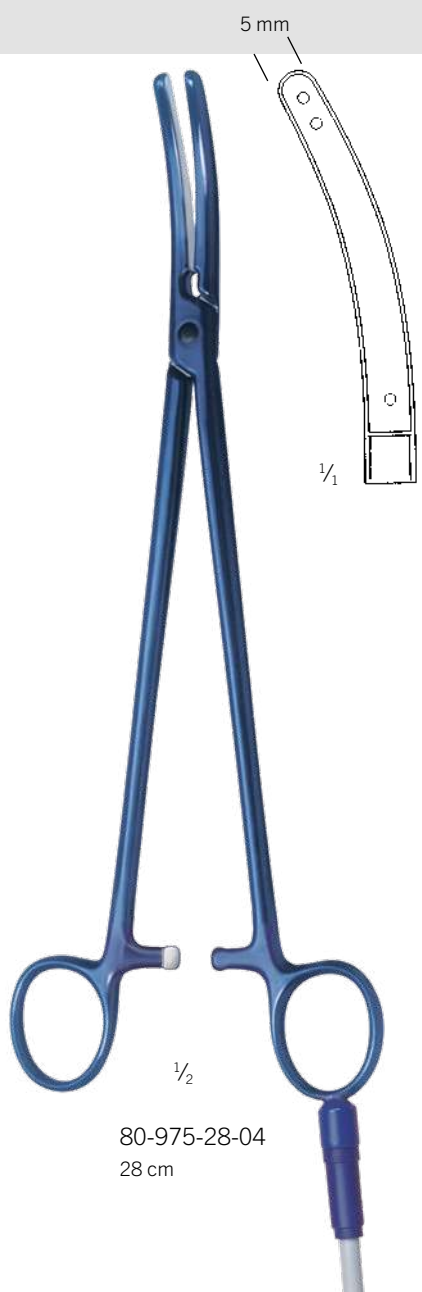

Weitere Informationen entnehmen Sie bitte der separaten Broschüre.  
 For further information please refer to our separate product brochure.  
 Encontrará informaciones adicionales en el folleto individual.  
 Vous trouverez des informations supplémentaires dans la brochure.  
 Per ulteriori informazioni vedasi il prospetto separato.

80-975-28-04  
 28 cm

Bipolare Klemmen für die Gefäßversiegelung  
 Bipolar forceps for vessel sealing  
 Pinzas bipolares para el sellado vascular  
 Pincès bipolaires pour le clamage vasculaire  
 Pinze bipolari per clampaggio vascolare

marClamp® IQ



✓ Präparieren	Dissect	Diseccionar	Disséquer	Sezionare
✓ Versiegeln	Seal	Sellar	Clamper	Sigillare
✓ <b>Plug &amp; Play</b>	<b>Plug &amp; Play</b>	<b>Plug &amp; Play</b>	<b>Plug &amp; Play</b>	<b>Plug &amp; Play</b>
✓ Wiederverwendbar	Reusable	Reutilizable	Réutilisable	Riutilizzabile



„Shark”  
 80-976-23-04  
 23 cm  
 marClamp®



Gemini  
 80-978-23-04  
 23 cm  
 marClamp®

Instrumentarium zur bipolaren Gefäßversiegelung  
 Instruments for bipolar vessel sealing  
 Instrumentos para el sellado vascular bipolar  
 Instruments pour la clampage vasculaire bipolaire  
 Strumenti di sigillatura vascolare bipolare



5

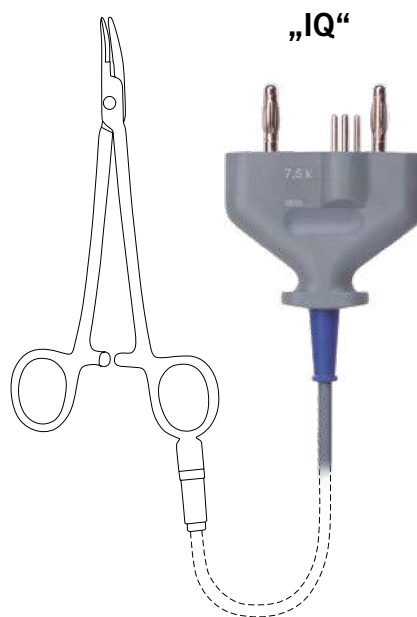

Kalem  
 80-977-23-04  
 24,5 cm  
 marClamp® Uro



Weitere Informationen entnehmen Sie bitte der separaten Broschüre.  
 For further information please refer to our separate product brochure.  
 Encontrará informaciones adicionales en el folleto individual.  
 Vous trouverez des informations supplémentaires dans la brochure.  
 Per ulteriori informazioni vedasi il prospetto separato.



Kombi-Instrument für die offenchirurgische Gefäßversiegelung  
 Combination instrument for open surgical vessel sealing  
 Instrumento combinado para el sellado vascular en cirugía abierta  
 Instrument combiné de scellement de vaisseaux sanguins pour la chirurgie ouverte  
 Strumento combinato per la sigillatura vascolare nella chirurgia a cielo aperto

**marClamp®** Cut IQ



✓ Präparieren	Dissect	Disecionar	Disséquer	Sezionare
✓ Versiegeln	Seal	Sellar	Clamper	Sigillare
✓ Trennen	Cut	Cortar	Couper	Separare
✓ <b>Plug &amp; Play</b>	<b>Plug &amp; Play</b>	<b>Plug &amp; Play</b>	<b>Plug &amp; Play</b>	<b>Plug &amp; Play</b>
✓ Kein Instrumentenwechsel	No need to exchange instruments	No es necesario cambiar de instrumento	Il n'est pas nécessaire de changer d'instruments	Senza necessità di cambiare strumento
✓ Wiederverwendbar	Reusable	Reutilizable	Réutilisable	Riutilizzabile

	marClamp®-Cut-IQ-System Instrument, komplett*, ohne Klingen	marClamp® Cut IQ System Instrument, complete*, without blades	Sistema marClamp® Cut IQ Instrumento, completo*, sin cuchillas
80-632-18-04	marClamp® Cut IQ, 18 cm	marClamp® Cut IQ, 18 cm	marClamp® Cut IQ, 18 cm

	Komponenten	Components	Componentes
80-632-00-04	Klinge für marClamp® Cut IQ, steril, VE=10	Blade for marClamp® Cut IQ, sterile, pack of 10	Cuchilla para marClamp® Cut IQ, estéril, UE=10
80-630-58-04	Reinigungswerkzeug	Cleaning tool	Herramienta de limpieza
80-632-01-04	Set Reinigungsbürsten, 3 Stück	Set of cleaning brushes, 3 pcs.	Juego de cepillos de limpieza, 3 unidades

\* incl. 80-630-58-04, 80-632-01-04  
 Klingen müssen separat bestellt werden

\* incl. 80-630-58-04, 80-632-01-04  
 Blades have to be ordered separately

\* incl. 80-630-58-04, 80-632-01-04  
 Las cuchillas se deben encargar por separado

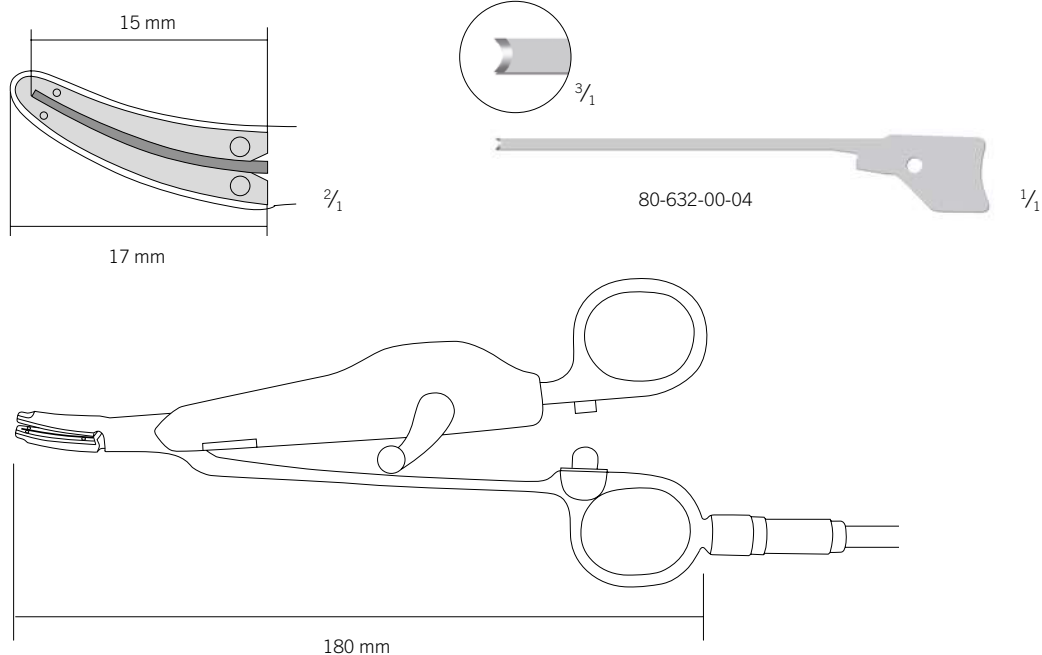

Instrumentarium zur bipolaren Gefäßversiegelung  
 Instruments for bipolar vessel sealing  
 Instrumentos para el sellado vascular bipolar  
 Instruments pour la clampage vasculaire bipolaire  
 Strumenti di sigillatura vascolare bipolare



Integrierter Schalter zur Handaktivierung  
 Integrated switch for manual activation  
 Interruptor integrado para la activación manual  
 Interrupteur intégré pour l'activation manuelle  
 Interruttore integrato per l'attivazione manuale



5

	<b>Système marClamp® Cut IQ</b> Instrument, complet*, sans lames	<b>Sistema marClamp® Cut IQ</b> Strumento, completo*, senza lame
80-632-18-04	marClamp® Cut IQ, 18 cm	marClamp® Cut IQ, 18 cm

	<b>Composants</b>	<b>Componenti</b>
80-632-00-04	Lame pour instrument marClamp® Cut IQ, stérile, UC=10	Lama per marClamp® Cut IQ, sterile, confezione=10 unità
80-630-58-04	Outil de nettoyage	Strumento di pulizia
80-632-01-04	Jeu de brosses de nettoyage, 3 unités	Set di spazzolini di pulizia, 3 pezzi

\* incl. 80-630-58-04, 80-632-01-04  
 Les lames doivent être commandées séparément

\* incl. 80-630-58-04, 80-632-01-04  
 Le lame devono essere ordinate a parte

„IQ“

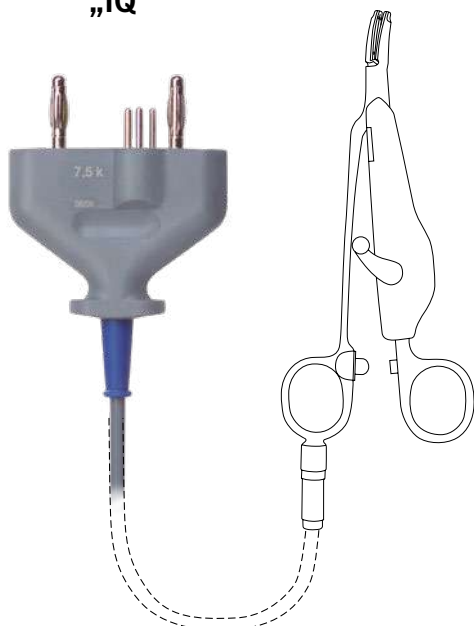

Weitere Informationen entnehmen Sie bitte der separaten Broschüre.

For further information please refer to our separate product brochure.

Encontrará informaciones adicionales en el folleto individual.

Vous trouverez des informations supplémentaires dans la brochure.

Per ulteriori informazioni vedasi il prospetto separato.

marSeal – bipolares Gefäßversiegelungssystem  
 marSeal – bipolar vessel sealing system  
 marSeal – sistema de sellado vascular bipolar  
 marSeal – système bipolaire de clamage de vaisseaux  
 marSeal – sistema bipolare di sigillatura dei vasi

**marSeal IQ**



<input checked="" type="checkbox"/> Präparieren	Dissect	Disecionar	Disséquer	Sezionare
<input checked="" type="checkbox"/> Versiegeln	Seal	Sellar	Clamper	Sigillare
<input checked="" type="checkbox"/> Trennen	Cut	Cortar	Couper	Separare
<input checked="" type="checkbox"/> <b>Plug &amp; Play</b>	<b>Plug &amp; Play</b>	<b>Plug &amp; Play</b>	<b>Plug &amp; Play</b>	<b>Plug &amp; Play</b>
<input checked="" type="checkbox"/> Kein Instrumentenwechsel	No need to exchange instruments	No es necesario cambiar de instrumento	Il n'est pas nécessaire de changer d'instruments	Senza necessità di cambiare strumento
<input checked="" type="checkbox"/> Wiederverwendbar	Reusable	Reutilizable	Réutilisable	Riutilizzabile

	marSeal-System Instrument, komplett*, ohne Klängen	marSeal System Instrument, complete*, without blades	Sistema marSeal Instrumento, completo*, sin cuchillas
80-630-41-04	„IQ“-Version	“IQ” version	Versión “IQ”

	Komponenten	Components	Componentes
80-630-45-04	Handgriff „IQ“	Handle “IQ”	Mango “IQ”
80-630-12-04	Rohrschaft**	Tubular shaft**	Vástago de tubo**
80-630-15-04	Klinge zum Einmalgebrauch, VE = 6 Stck.	Disposable blade, SU = 6/pack	Hoja desechable, UV = 6 piezas
80-630-16-04	Klinge zum Einmalgebrauch, steril, VE = 10 Stck	Disposable blade, SU = 10/pack	Hoja desechable, UV = 10 piezas
80-630-17-04	Reinigungswerkzeug	Cleaning tool	Herramienta de limpieza
80-630-18-04	Spüladapter	Flushing adapter	Adaptador de enjuague

\* inkl. 80-630-17-04, 80-630-18-04  
 \*\* inkl. 80-630-17-04  
 Klängen müssen separat bestellt werden

\* incl. 80-630-17-04, 80-630-18-04  
 \*\* incl. 80-630-17-04  
 Blades have to be ordered separately

\* incl. 80-630-17-04, 80-630-18-04  
 \*\* incl. 80-630-17-04  
 Las cuchillas se deben encargar por separado

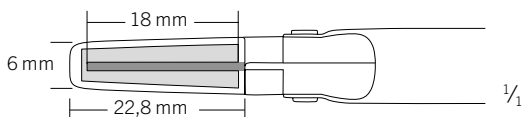

80-630-15-04 / 80-630-16-04



Instrumentarium zur bipolaren Gefäßversiegelung  
 Instruments for bipolar vessel sealing  
 Instrumentos para el sellado vascular bipolar  
 Instruments pour la clampage vasculaire bipolaire  
 Strumenti di sigillatura vascolare bipolare



Über Fingerschaltung aktivierbar  
 Can be activated via finger switch operation  
 Puede activarse a través de interruptor manual  
 Activable par commande manuelle  
 Attivazione tramite l'interruttore manuale



5

	<b>Système marSeal</b> Instrument, complet*, sans lames	<b>Sistema marSeal</b> Strumento, completo*, senza lame
80-630-41-04	Version «IQ»	Versione "IQ"

	<b>Composants</b>	<b>Componenti</b>
80-630-45-04	Manche «IQ»	Impugnatura "IQ"
80-630-12-04	Tige tubulaire**	Guaina tubo**
80-630-15-04	Lame à usage unique, UC = 6 unités	Lama monouso, UV = 6 pezzi
80-630-16-04	Lame à usage unique, UC = 10 unités	Lama monouso, UV = 10 pezzi
80-630-17-04	Outil de nettoyage	Strumento di pulizia
80-630-18-04	Adaptateur de rinçage	Adattatore di lavaggio

\* incl. 80-630-17-04, 80-630-18-04  
 \*\* incl. 80-630-17-04  
 Les lames doivent être commandées séparément

\* incl. 80-630-17-04, 80-630-18-04  
 \*\* incl. 80-630-17-04  
 Le lame devono essere ordinate a parte



4 m



Weitere Informationen entnehmen Sie bitte der separaten Broschüre.  
 For further information please refer to our separate product brochure.  
 Encontrará informaciones adicionales en el folleto individual.  
 Vous trouverez des informations supplémentaires dans la brochure.  
 Per ulteriori informazioni vedasi il prospetto separato.

marSeal slim – bipolares Gefäßversiegelungssystem  
 marSeal slim – bipolar vessel sealing system  
 marSeal slim – sistema de sellado vascular bipolar  
 marSeal slim – système bipolaire de clampage de vaisseaux  
 marSeal slim – sistema bipolare di sigillatura dei vasi

**marSeal** slim IQ



✓ Präparieren	Dissect	Disecionar	Disséquer	Sezionare
✓ Versiegeln	Seal	Sellar	Clamper	Sigillare
✓ Trennen	Cut	Cortar	Couper	Separare
✓ <b>Plug &amp; Play</b>	<b>Plug &amp; Play</b>	<b>Plug &amp; Play</b>	<b>Plug &amp; Play</b>	<b>Plug &amp; Play</b>
✓ Kein Instrumentenwechsel	No need to exchange instruments	No es necesario cambiar de instrumento	Il n'est pas nécessaire de changer d'instruments	Senza necessità di cambiare strumento
✓ Wiederverwendbar	Reusable	Reutilizable	Réutilisable	Riutilizzabile

	marSeal-slim-System Instrument, komplett*, ohne Klingen	marSeal slim System Instrument, complete*, without blades	Sistema marSeal slim Instrumento, completo*, sin cuchillas
80-630-42-04	„IQ“-Version, Schaftlänge 370 mm	“IQ” version, shaft length 370 mm	Versión “IQ”, longitud de vástago 370 mm
80-630-43-04	„IQ“-Version, Schaftlänge 200 mm	“IQ” version, shaft length 200 mm	Versión “IQ”, longitud de vástago 200 mm

	Komponenten	Components	Componentes
80-630-45-04	Handgriff „IQ“	Handle “IQ”	Mango “IQ”
80-630-34-04	Rohrschaft, Länge 370 mm**	Tubular shaft, 370 mm long**	Vástago de tubo, longitud 370 mm**
80-630-35-04	Rohrschaft, Länge 200 mm**	Tubular shaft, 200 mm long**	Vástago de tubo, longitud 200 mm**
80-630-15-04	Klinge zum Einmalgebrauch, VE = 6 Stck.	Disposable blade, SU = 6/pack	Hoja desechable, UV = 6 piezas
80-630-16-04	Klinge zum Einmalgebrauch, VE = 10 Stck.	Disposable blade, SU = 10/pack	Hoja desechable, UV = 10 piezas
80-630-17-04	Reinigungswerkzeug	Cleaning tool	Herramienta de limpieza
80-630-18-04	Spüladapter	Flushing adapter	Adaptador de enjuague

\* inkl. 80-630-17-04, 80-630-18-04  
 \*\* inkl. 80-630-17-04  
 Klingen müssen separat bestellt werden

\* incl. 80-630-17-04, 80-630-18-04  
 \*\* incl. 80-630-17-04  
 Blades have to be ordered separately

\* incl. 80-630-17-04, 80-630-18-04  
 \*\* incl. 80-630-17-04  
 Las cuchillas se deben encargar por separado

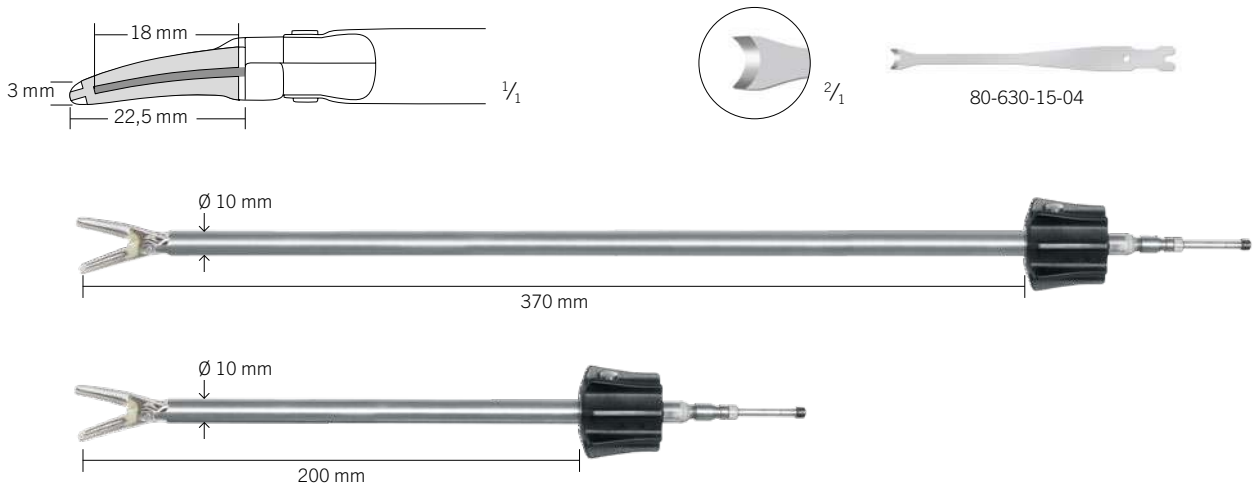

Instrumentarium zur bipolaren Gefäßversiegelung  
 Instruments for bipolar vessel sealing  
 Instrumentos para el sellado vascular bipolar  
 Instruments pour la clampage vasculaire bipolaire  
 Strumenti di sigillatura vascolare bipolare



Über Fingerschaltung aktivierbar  
 Can be activated via finger switch operation  
 Puede activarse a través de interruptor manual  
 Activable par commande manuelle  
 Attivazione tramite l'interruttore manuale



5

	<b>Système marSeal slim</b> Instrument, complet*, sans lames	<b>Sistema marSeal slim</b> Strumento, completo*, senza lame
80-630-42-04	Version «IQ», longueur de tige 370 mm	Versione «IQ», lunghezza guaina 370 mm
80-630-43-04	Version «IQ», longueur de tige 200 mm	Versione «IQ», lunghezza guaina 200 mm

	<b>Composants</b>	<b>Componenti</b>
80-630-45-04	Manche «IQ»	Impugnatura «IQ»
80-630-34-04	Tige tubulaire, longueur 370 mm**	Lunghezza guaina tubo 370 mm**
80-630-35-04	Tige tubulaire, longueur 200 mm**	Lunghezza guaina tubo 200 mm**
80-630-15-04	Lame à usage unique, UC = 6 unités	Lama monouso, UV = 6 pezzi
80-630-16-04	Lame à usage unique, UC = 10 unités	Lama monouso, UV = 10 pezzi
80-630-17-04	Outil de nettoyage	Strumento di pulizia
80-630-18-04	Adaptateur de rinçage	Adattatore di lavaggio

\* incl. 80-630-17-04, 80-630-18-04  
 \*\* incl. 80-630-17-04  
 Les lames doivent être commandées séparément

\* incl. 80-630-17-04, 80-630-18-04  
 \*\* incl. 80-630-17-04  
 Le lame devono essere ordinate a parte



Weitere Informationen entnehmen Sie bitte der separaten Broschüre.  
 For further information please refer to our separate product brochure.  
 Encontrará informaciones adicionales en el folleto individual.  
 Vous trouverez des informations supplémentaires dans la brochure.  
 Per ulteriori informazioni vedasi il prospetto separato.

marSeal5 – bipolares Gefäßversiegelungssystem  
 marSeal5 – bipolar vessel sealing system  
 marSeal5 – sistema de sellado vascular bipolar  
 marSeal5 – système bipolaire de clampage de vaisseaux  
 marSeal5 – sistema bipolare di sigillatura dei vasi

**marSeal5 IQ**



<input checked="" type="checkbox"/> Präparieren	Dissect	Disecionar	Disséquer	Sezionare
<input checked="" type="checkbox"/> Versiegeln	Seal	Sellar	Clamper	Sigillare
<input checked="" type="checkbox"/> Trennen	Cut	Cortar	Couper	Separare
<input checked="" type="checkbox"/> <b>Plug &amp; Play</b>	<b>Plug &amp; Play</b>	<b>Plug &amp; Play</b>	<b>Plug &amp; Play</b>	<b>Plug &amp; Play</b>
<input checked="" type="checkbox"/> Kein Instrumentenwechsel	No need to exchange instruments	No es necesario cambiar de instrumento	Il n'est pas nécessaire de changer d'instruments	Senza necessità di cambiare strumento
<input checked="" type="checkbox"/> Wiederverwendbar	Reusable	Reutilizable	Réutilisable	Riutilizzabile

	marSeal5-System Instrument, komplett*, ohne Klinsen	marSeal5 System Instrument, complete*, without blades	Sistema marSeal5 Instrumento, completo*, sin cuchillas
80-630-50-04	„IQ“-Version, Schaftlänge 370 mm	“IQ” version, shaft length 370 mm	Versión “IQ”, longitud de vástago 370 mm
80-630-90-04	„IQ“-Version short, Schaftlänge 200 mm	“IQ” version, short, shaft length 200 mm	Versión “IQ” short, longitud de vástago 200 mm

	Komponenten	Components	Componentes
80-630-52-04	Handgriff „IQ“	Handle “IQ”	Mango “IQ”
80-630-51-04	Rohrschaft, Länge 370 mm**	Tubular shaft, 370 mm long**	Vástago tubular, longitud 370 mm**
80-630-92-04	Rohrschaft, Länge 200 mm**	Tubular shaft, 200 mm long**	Vástago tubular, longitud 200 mm**
80-630-53-04	Klingenträger, Länge 370 mm, zum Einmalgebrauch, VE = 6 Stck.	Disposable blade rod, 370 mm long, SU = 6/pack	Soporte desechable, longitud 370 mm, UE = 6 unidades
80-630-91-04	Klingenträger, Länge 200 mm, zum Einmalgebrauch, VE = 6 Stck.	Disposable blade rod, 200 mm long, SU = 6/pack	Soporte desechable, longitud 200 mm, UE = 6 unidades
80-630-83-04	Klingenträger, Länge 370 mm, zum Einmalgebrauch, <b>steril</b> , VE = 10 Stck.	Disposable blade rod, 370 mm long, <b>sterile</b> , SU = 10/pack	Soporte desechable, longitud 370 mm, <b>estéril</b> , UE = 10 unidades
80-630-58-04	Reinigungswerkzeug	Cleaning tool	Herramienta de limpieza
80-630-59-04	Spüladapter	Flushing adapter	Adaptador de enjuague

\* inkl. 80-630-58-04, 80-630-59-04  
 \*\* inkl. 80-630-58-04  
 Klinsen müssen separat bestellt werden

\* incl. 80-630-58-04, 80-630-59-04  
 \*\* incl. 80-630-58-04  
 Blades have to be ordered separately

\* incl. 80-630-58-04, 80-630-59-04  
 \*\* incl. 80-630-58-04  
 Las cuchillas se deben encargar por separado

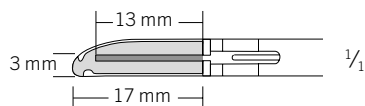

marSeal5 IQ

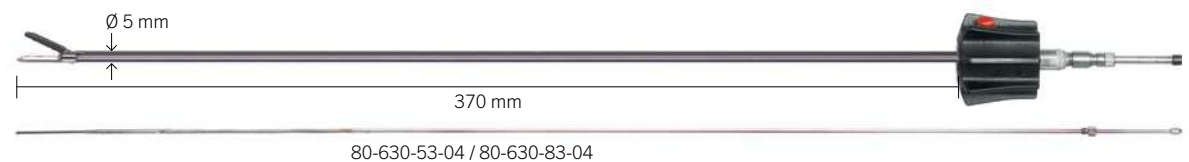

marSeal5 IQ short



Instrumentarium zur bipolaren Gefäßversiegelung  
 Instruments for bipolar vessel sealing  
 Instrumentos para el sellado vascular bipolar  
 Instruments pour la clampage vasculaire bipolaire  
 Strumenti di sigillatura vascolare bipolare



Über Fingerschaltung aktivierbar  
 Can be activated via finger switch operation  
 Puede activarse a través de interruptor manual  
 Activable par commande manuelle  
 Attivazione tramite l'interruttore manuale



5

	<b>Système marSeal5</b> Instrument, complet*, sans lames	<b>Sistema marSeal5</b> Strumento, completo*, senza lame
80-630-50-04	Version «IQ», longueur de tige 370 mm	Versione «IQ», lunghezza guaina 370 mm
80-630-90-04	Version «IQ» short, longueur de tige 200 mm	Versione «IQ» short, lunghezza guaina 200 mm

	<b>Composants</b>	<b>Componenti</b>
80-630-52-04	Poignée «IQ»	Impugnatura «IQ»
80-630-51-04	Tige tubulaire marSeal5, longueur 370 mm**	Lunghezza guaina tubo 370 mm**
80-630-92-04	Tige tubulaire marSeal5, longueur 200 mm**	Lunghezza guaina tubo 200 mm**
80-630-53-04	Porte-lame à usage unique, longueur 370 mm, UE = 6 pièces	Portalama monouso, lunghezza 370 mm, UV = 6 pezzi
80-630-91-04	Porte-lame à usage unique, longueur 200 mm, UE = 6 pièces	Portalama monouso, lunghezza 200 mm, UV = 6 pezzi
80-630-83-04	Porte-lame à usage unique, longueur 370 mm, <b>stérile</b> , UE = 10 pièces	Portalama monouso, lunghezza 370 mm, <b>sterilmente</b> , UV = 10 pezzi
80-630-58-04	Outil de nettoyage	Strumento di pulizia
80-630-59-04	Adaptateur de rinçage	Adattatore di lavaggio

\* incl. 80-630-58-04, 80-630-59-04  
 \*\* incl. 80-630-58-04  
 Les lames doivent être commandées séparément

\* incl. 80-630-58-04, 80-630-59-04  
 \*\* incl. 80-630-58-04  
 Le lame devono essere ordinate a parte



4 m



Weitere Informationen entnehmen Sie bitte der separaten Broschüre.

For further information please refer to our separate product brochure.

Encontrará informaciones adicionales en el folleto individual.

Vous trouverez des informations supplémentaires dans la brochure.

Per ulteriori informazioni vedasi il prospetto separato.



marSeal5 plus – bipolares Gefäßversiegelungssystem  
 marSeal5 plus – bipolar vessel sealing system  
 marSeal5 plus – sistema de sellado vascular bipolar  
 marSeal5 plus – système bipolaire de clampage de vaisseaux  
 marSeal5 plus – sistema bipolare di sigillatura dei vasi

**marSeal5 plus**



## Vessel Sealing in a new Dimension!



✓ Präparieren	Dissect	Disecionar	Disséquer	Sezionare
✓ Versiegeln	Seal	Sellar	Clamper	Sigillare
✓ Trennen	Cut	Cortar	Couper	Separare
✓ <b>Plug &amp; Play</b>	<b>Plug &amp; Play</b>	<b>Plug &amp; Play</b>	<b>Plug &amp; Play</b>	<b>Plug &amp; Play</b>
✓ Kein Instrumentenwechsel	No need to exchange instruments	No es necesario cambiar de instrumento	Il n'est pas nécessaire de changer d'instruments	Senza necessità di cambiare strumento
✓ Wiederverwendbar	Reusable	Reutilizable	Réutilisable	Riutilizzabile

	marSeal5-plus-System Instrument, komplett*, ohne Klingen	marSeal5 plus System Instrument, complete*, without blades	Sistema marSeal5 plus Instrumento, completo*, sin cuchillas
80-633-00-04	marSeal5 plus IQ Schaftlänge 370 mm	marSeal5 plus IQ shaft length 370 mm	marSeal5 plus IQ longitud del vástago 370 mm

	Einzelkomponenten	Individual components	Componentes individuales
80-633-04-04	Handgriff	Handle	Mango
80-633-05-04	Rohrschaft, Ø 5 mm, Schaftlänge 370 mm, bestehend aus Außen- und Innenrohr**	Tubular shaft, Ø 5 mm, shaft length 370 mm, consisting of outer and inner tube**	Vástago tubular, Ø 5 mm, longitud del vástago 370 mm, compuesto por tubo externo e interno**

	Verbrauchsmaterial	Consumables	Consumibles
80-633-09-04	Klingenträger, 370 mm, steril, VE=10 Stück	Blade holder, 370 mm, sterile, PU=10 pieces	Portacuchillas, 370 mm, estéril, UE=10 unidades
80-633-11-04	Klingenträger, 370 mm, unsteril, VE=10 Stück	Blade holder, 370 mm, non-sterile, PU=10 pieces	Portacuchillas, 370 mm, no estéril, UE=10 unidades

	Reinigungs- und Aufbereitungs-Tools	Cleaning and reprocessing tools	Herramientas de limpieza y acondicionamiento
80-633-12-04	Reinigungswerkzeug	Cleaning tool	Herramienta de limpieza
80-633-13-04	Spüladapter für Außen- und Innenrohr	Rinsing adapter for outer and inner tube	Adaptador de lavado por tubo externo e interno

\* inkl. 80-633-12-04, 80-633-13-04  
 \*\* inkl. 80-633-12-04  
 Klingen müssen separat bestellt werden

\* incl. 80-633-12-04, 80-633-13-04  
 \*\* incl. 80-633-12-04  
 Blades have to be ordered separately

\* incl. 80-633-12-04, 80-633-13-04  
 \*\* incl. 80-633-12-04  
 Las cuchillas se deben encargar por separado

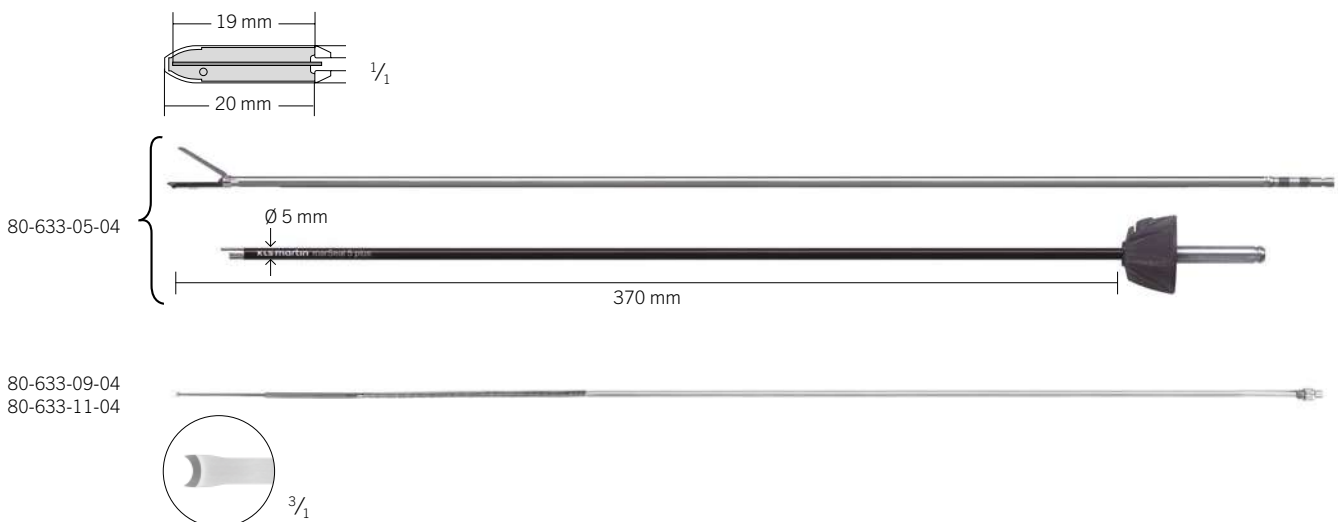



Über Fingerschaltung aktivierbar  
 Can be activated via finger switch operation  
 Puede activarse a través de interruptor manual  
 Activable par commande manuelle  
 Attivazione tramite l'interruttore manuale



5

	<b>Système marSeal5 plus</b>	<b>Sistema marSeal5 plus</b>
	<b>Instrument, complet*, sans lames</b>	<b>Strumento, completo*, senza lame</b>
80-633-00-04	marSeal5 plus IQ longueur 370 mm	marSeal5 plus IQ lunghezza 370 mm
	<b>Composants individuels</b>	<b>Componenti singoli</b>
80-633-04-04	Poignée	Impugnatura
80-633-05-04	Tige tubulaire, Ø 5 mm, longueur 370 mm, composée d'un tube externe et interne**	Stelo tubulare, Ø 5 mm, lunghezza 370 mm, composto da tubo esterno ed interno**
	<b>Consommables</b>	<b>Materiale di consumo</b>
80-633-09-04	Porte-lame, 370 mm, <b>stérile</b> , UV=10 pièces	Portalama, 370 mm, <b>sterile</b> , UV=10 pezzi
80-633-11-04	Porte-lame, 370 mm, non-stérile, UV=10 pièces	Portalama, 370 mm, non sterile, UV=10 pezzi
	<b>Outils de nettoyage et de préparation</b>	<b>Strumenti di pulizia e condizionamento</b>
80-633-12-04	Outil de nettoyage	Utensile di pulizia
80-633-13-04	Adaptateur de rinçage pour tige tubulaire externe et interne	Adattatore di lavaggio per tubo esterno ed interno

\* incl. 80-633-12-04, 80-633-13-04  
 \*\* incl. 80-633-12-04  
 Les lames doivent être commandées séparément

\* incl. 80-633-12-04, 80-633-13-04  
 \*\* incl. 80-633-12-04  
 Le lame devono essere ordinate a parte

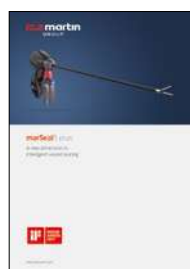
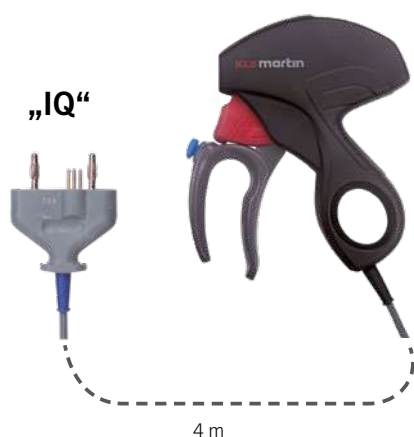

Weitere Informationen entnehmen Sie bitte der separaten Broschüre.  
 For further information please refer to our separate product brochure.  
 Encontrará informaciones adicionales en el folleto individual.  
 Vous trouverez des informations supplémentaires dans la brochure.  
 Per ulteriori informazioni vedasi il prospetto separato.

marSeal5 plus Maryland – bipolares Gefäßversiegelungssystem  
 marSeal5 plus Maryland – bipolar vessel sealing system  
 marSeal5 plus Maryland – sistema de sellado vascular bipolar  
 marSeal5 plus Maryland – système bipolaire de clampage de vaisseaux  
 marSeal5 plus Maryland – sistema bipolare di sigillatura dei vasi

# marSeal5 plus Maryland



Outstanding dissection and sealing performance guarantees ultimate efficiency for your patients!



✓ Präparieren	Dissect	Disecionar	Disséquer	Sezionare
✓ Versiegeln	Seal	Sellar	Clamper	Sigillare
✓ Trennen	Cut	Cortar	Couper	Separare
✓ <b>Plug &amp; Play</b>	<b>Plug &amp; Play</b>	<b>Plug &amp; Play</b>	<b>Plug &amp; Play</b>	<b>Plug &amp; Play</b>
✓ Kein Instrumentenwechsel	No need to exchange instruments	No es necesario cambiar de instrumento	Il n'est pas nécessaire de changer d'instruments	Senza necessità di cambiare strumento
✓ Wiederverwendbar	Reusable	Reutilizable	Réutilisable	Riutilizzabile

	marSeal5-plus-Maryland-System Instrument, komplett*, ohne Klängen	marSeal5 plus Maryland System Instrument, complete*, without blades	Sistema marSeal5 plus Maryland Instrumento, completo*, sin cuchillas
80-633-01-04	marSeal5 plus Maryland IQ Schaftlänge 450 mm	marSeal5 plus Maryland IQ shaft length 450 mm	marSeal5 plus Maryland IQ longitud del vástago 450 mm

	Einzelkomponenten	Individual components	Componentes individuales
80-633-04-04	Handgriff	Handle	Mango
80-633-06-04	Rohrschaft, Ø 5 mm, Schaftlänge 450 mm, bestehend aus Außen- und Innenrohr**	Tubular shaft, Ø 5 mm, shaft length 450 mm, consisting of outer and inner tube**	Vástago tubular, Ø 5 mm, longitud del vástago 450 mm, compuesto por tubo externo e interno**

	Verbrauchsmaterial	Consumables	Consumibles
80-633-15-04	Klingenträger, 450 mm, steril, VE=10 Stück	Blade holder, 450 mm, sterile, PU=10 pieces	Portacuchillas, 450 mm, estéril, UE=10 unidades
80-633-16-04	Klingenträger, 450 mm, unsteril, VE=10 Stück	Blade holder, 450 mm, non-sterile, PU=10 pieces	Portacuchillas, 450 mm, no estéril, UE=10 unidades

	Reinigungs- und Aufbereitungs-Tools	Cleaning and reprocessing tools	Herramientas de limpieza y acondicionamiento
80-633-12-04	Reinigungswerkzeug	Cleaning tool	Herramienta de limpieza
80-633-13-04	Spüladapter für Außen- und Innenrohr	Rinsing adapter for outer and inner tube	Adaptador de lavado por tubo externo e interno

\* inkl. 80-633-12-04, 80-633-13-04  
 \*\* inkl. 80-633-12-04  
 Klängen müssen separat bestellt werden

\* incl. 80-633-12-04, 80-633-13-04  
 \*\* incl. 80-633-12-04  
 Blades have to be ordered separately

\* incl. 80-633-12-04, 80-633-13-04  
 \*\* incl. 80-633-12-04  
 Las cuchillas se deben encargar por separado

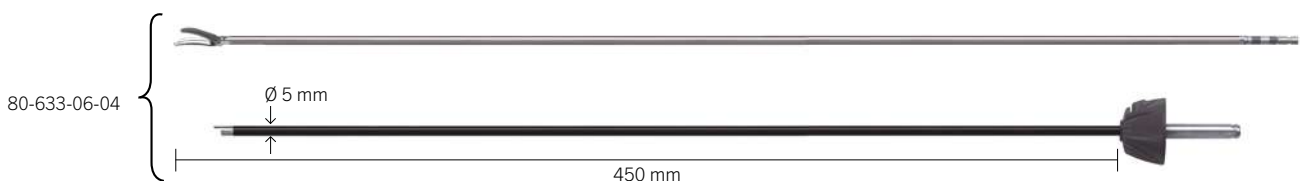
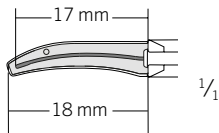

80-633-15-04  
 80-633-16-04

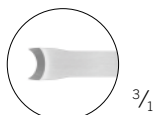



45 cm  
 bariatriche Länge  
 bariatric length  
 longitud bariátrica  
 longueur bariátrique  
 lunghezza bariátrica



5

	<b>Système marSeal5 plus Maryland</b> <b>Instrument, complet*, sans lames</b>	<b>Sistema marSeal5 plus Maryland</b> <b>Strumento, completo*, senza lame</b>
80-633-01-04	marSeal5 plus Maryland IQ longueur de tige 50 mm	marSeal5 plus Maryland IQ lunghezza guaina 450 mm
	<b>Composants individuels</b>	<b>Componenti singoli</b>
80-633-04-04	Poignée	Impugnatura
80-633-06-04	Tige tubulaire, Ø 5 mm, longueur de tige 450 mm, composée d'un tube externe et interne**	Stelo tubulare, Ø 5 mm, lunghezza guaina 450 mm, composto da tubo esterno ed interno**
	<b>Consommables</b>	<b>Materiale di consumo</b>
80-633-15-04	Porte-lame, 450 mm, <b>stérile</b> , UV=10 pièces	Portalama, 450 mm, <b>sterile</b> , UV=10 pezzi
80-633-16-04	Porte-lame, 450 mm, non-stérile, UV=10 pièces	Portalama, 450 mm, non sterile, UV=10 pezzi
	<b>Outils de nettoyage et de préparation</b>	<b>Strumenti di pulizia e condizionamento</b>
80-633-12-04	Outil de nettoyage	Utensile di pulizia
80-633-13-04	Adaptateur de rinçage pour tige tubulaire externe et interne	Adattatore di lavaggio per tubo esterno ed interno

\* incl. 80-633-12-04, 80-633-13-04  
 \*\* incl. 80-633-12-04  
 Les lames doivent être commandées séparément

\* incl. 80-633-12-04, 80-633-13-04  
 \*\* incl. 80-633-12-04  
 Le lame devono essere ordinate a parte



Weitere Informationen entnehmen Sie bitte der separaten Broschüre.  
 For further information please refer to our separate product brochure.  
 Encontrará informaciones adicionales en el folleto individual.  
 Vous trouverez des informations supplémentaires dans la brochure.  
 Per ulteriori informazioni vedasi il prospetto separato.

marSeal5 plus Maryland – bipolares Gefäßversiegelungssystem  
 marSeal5 plus Maryland – bipolar vessel sealing system  
 marSeal5 plus Maryland – sistema de sellado vascular bipolar  
 marSeal5 plus Maryland – système bipolaire de clamage de vaisseaux  
 marSeal5 plus Maryland – sistema bipolare di sigillatura dei vasi

# marSeal5 plus Maryland



Outstanding dissection and sealing performance guarantees ultimate efficiency for your patients!



✓ Präparieren	Dissect	Disecionar	Disséquer	Sezionare
✓ Versiegeln	Seal	Sellar	Clamper	Sigillare
✓ Trennen	Cut	Cortar	Couper	Separare
✓ <b>Plug &amp; Play</b>	<b>Plug &amp; Play</b>	<b>Plug &amp; Play</b>	<b>Plug &amp; Play</b>	<b>Plug &amp; Play</b>
✓ Kein Instrumentenwechsel	No need to exchange instruments	No es necesario cambiar de instrumento	Il n'est pas nécessaire de changer d'instruments	Senza necessità di cambiare strumento
✓ Wiederverwendbar	Reusable	Reutilizable	Réutilisable	Riutilizzabile

	marSeal5-plus-Maryland-System Instrument, komplett*, ohne Klängen	marSeal5 plus Maryland System Instrument, complete*, without blades	Sistema marSeal5 plus Maryland Instrumento, completo*, sin cuchillas
80-633-02-04	marSeal5 plus Maryland IQ Schaftlänge 370 mm	marSeal5 plus Maryland IQ shaft length 370 mm	marSeal5 plus Maryland IQ longitud del vástago 370 mm

	Einzelkomponenten	Individual components	Componentes individuales
80-633-04-04	Handgriff	Handle	Mango
80-633-07-04	Rohrschaft, Ø 5 mm, Schaftlänge 370 mm, bestehend aus Außen- und Innenrohr**	Tubular shaft, Ø 5 mm, shaft length 370 mm, consisting of outer and inner tube**	Vástago tubular, Ø 5 mm, longitud del vástago 370 mm, compuesto por tubo externo e interno**

\*

	Verbrauchsmaterial	Consumables	Consumibles
80-633-09-04	Klingenträger, 370 mm, steril, VE=10 Stück	Blade holder, 370 mm, sterile, PU=10 pieces	Portacuchillas, 370 mm, estéril, UE=10 unidades
80-633-11-04	Klingenträger, 370 mm, unsteril, VE=10 Stück	Blade holder, 370 mm, non-sterile, PU=10 pieces	Portacuchillas, 370 mm, no estéril, UE=10 unidades

	Reinigungs- und Aufbereitungs-Tools	Cleaning and reprocessing tools	Herramientas de limpieza y acondicionamiento
80-633-12-04	Reinigungswerkzeug	Cleaning tool	Herramienta de limpieza
80-633-13-04	Spüladapter für Außen- und Innenrohr	Rinsing adapter for outer and inner tube	Adaptador de lavado por tubo externo e interno

\* inkl. 80-633-12-04, 80-633-13-04  
 \*\* inkl. 80-633-12-04  
 Klängen müssen separat bestellt werden

\* incl. 80-633-12-04, 80-633-13-04  
 \*\* incl. 80-633-12-04  
 Blades have to be ordered separately

\* incl. 80-633-12-04, 80-633-13-04  
 \*\* incl. 80-633-12-04  
 Las cuchillas se deben encargar por separado

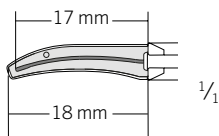

80-633-09-04  
 80-633-11-04

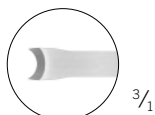



37 cm  
 für laparoskopische Standard-Eingriffe  
 for standard laparoscopic operations  
 para intervenciones laparoscópicas estándar  
 pour les interventions laparoscopiques standard  
 per interventi laparoscopici standard



5

	<b>Système marSeal5 plus Maryland Instrument, complet*, sans lames</b>	<b>Sistema marSeal5 plus Maryland Strumento, completo*, senza lame</b>
80-633-02-04	marSeal5 plus Maryland IQ longueur de tige 370 mm	marSeal5 plus Maryland IQ lunghezza guaina 370 mm
	<b>Composants individuels</b>	<b>Componenti singoli</b>
80-633-04-04	Poignée	Impugnatura
80-633-07-04	Tige tubulaire, Ø 5 mm, longueur de tige 370 mm, composée d'un tube externe et interne**	Stelo tubulare, Ø 5 mm, lunghezza guaina 370 mm, composto da tubo esterno ed interno**
	<b>Consommables</b>	<b>Materiale di consumo</b>
80-633-09-04	Porte-lame, 370 mm, <b>stérile</b> , UV=10 pièces	Portalama, 370 mm, <b>sterile</b> , UV=10 pezzi
80-633-11-04	Porte-lame, 370 mm, non-stérile, UV=10 pièces	Portalama, 370 mm, non sterile, UV=10 pezzi
	<b>Outils de nettoyage et de préparation</b>	<b>Strumenti di pulizia e condizionamento</b>
80-633-12-04	Outil de nettoyage	Untensile di pulizia
80-633-13-04	Adaptateur de rinçage pour tige tubulaire externe et interne	Adattatore di lavaggio per tubo esterno ed interno

\* incl. 80-633-12-04, 80-633-13-04  
 \*\* incl. 80-633-12-04  
 Les lames doivent être commandées séparément

\* incl. 80-633-12-04, 80-633-13-04  
 \*\* incl. 80-633-12-04  
 Le lame devono essere ordinate a parte

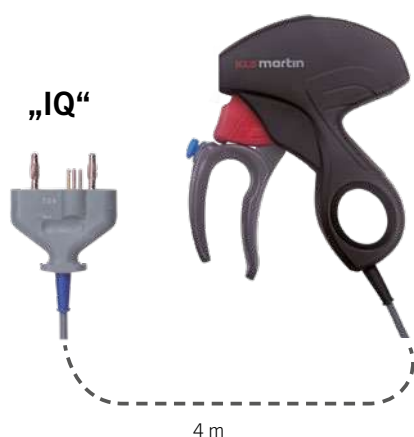

Weitere Informationen entnehmen Sie bitte der separaten Broschüre.  
 For further information please refer to our separate product brochure.  
 Encontrará informaciones adicionales en el folleto individual.  
 Vous trouverez des informations supplémentaires dans la brochure.  
 Per ulteriori informazioni vedasi il prospetto separato.

marSeal5 plus Maryland – bipolares Gefäßversiegelungssystem  
 marSeal5 plus Maryland – bipolar vessel sealing system  
 marSeal5 plus Maryland – sistema de sellado vascular bipolar  
 marSeal5 plus Maryland – système bipolaire de clamage de vaisseaux  
 marSeal5 plus Maryland – sistema bipolare di sigillatura dei vasi

# marSeal5 plus Maryland



Outstanding dissection and sealing performance guarantees ultimate efficiency for your patients!



✓ Präparieren	Dissect	Disecionar	Disséquer	Sezionare
✓ Versiegeln	Seal	Sellar	Clamper	Sigillare
✓ Trennen	Cut	Cortar	Couper	Separare
✓ <b>Plug &amp; Play</b>	<b>Plug &amp; Play</b>	<b>Plug &amp; Play</b>	<b>Plug &amp; Play</b>	<b>Plug &amp; Play</b>
✓ Kein Instrumentenwechsel	No need to exchange instruments	No es necesario cambiar de instrumento	Il n'est pas nécessaire de changer d'instruments	Senza necessità di cambiare strumento
✓ Wiederverwendbar	Reusable	Reutilizable	Réutilisable	Riutilizzabile

	marSeal5-plus-Maryland-System Instrument, komplett*, ohne Klängen	marSeal5 plus Maryland System Instrument, complete*, without blades	Sistema marSeal5 plus Maryland Instrumento, completo*, sin cuchillas
80-633-03-04	marSeal5 plus Maryland IQ Schaftlänge 230 mm	marSeal5 plus Maryland IQ shaft length 230 mm	marSeal5 plus Maryland IQ longitud del vástago 230 mm

	Einzelkomponenten	Individual components	Componentes individuales
80-633-04-04	Handgriff	Handle	Mango
80-633-08-04	Rohrschaft, Ø 5 mm, Schaftlänge 230 mm, bestehend aus Außen- und Innenrohr**	Tubular shaft, Ø 5 mm, shaft length 230 mm, consisting of outer and inner tube**	Vástago tubular, Ø 5 mm, longitud del vástago 230 mm, compuesto por tubo externo e interno**

	Verbrauchsmaterial	Consumables	Consumibles
80-633-10-04	Klingenträger, 230 mm, steril, VE=10 Stück	Blade holder, 230 mm, sterile, PU=10 pieces	Portacuchillas, 230 mm, estéril, UE=10 unidades
80-633-14-04	Klingenträger, 230 mm, unsteril, VE=10 Stück	Blade holder, 230 mm, non-sterile, PU=10 pieces	Portacuchillas, 230 mm, no estéril, UE=10 unidades

	Reinigungs- und Aufbereitungs-Tools	Cleaning and reprocessing tools	Herramientas de limpieza y acondicionamiento
80-633-12-04	Reinigungswerkzeug	Cleaning tool	Herramienta de limpieza
80-633-13-04	Spüladapter für Außen- und Innenrohr	Rinsing adapter for outer and inner tube	Adaptador de lavado por tubo externo e interno

\* inkl. 80-633-12-04, 80-633-13-04  
 \*\* inkl. 80-633-12-04  
 Klängen müssen separat bestellt werden

\* incl. 80-633-12-04, 80-633-13-04  
 \*\* incl. 80-633-12-04  
 Blades have to be ordered separately

\* incl. 80-633-12-04, 80-633-13-04  
 \*\* incl. 80-633-12-04  
 Las cuchillas se deben encargar por separado

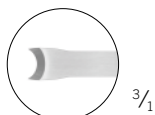
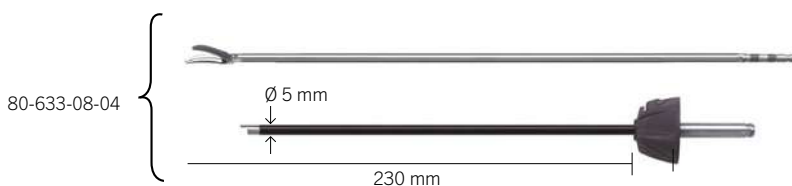
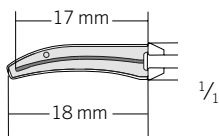

Instrumentarium zur bipolaren Gefäßversiegelung  
 Instruments for bipolar vessel sealing  
 Instrumentos para el sellado vascular bipolar  
 Instruments pour la clampage vasculaire bipolaire  
 Strumenti di sigillatura vascolare bipolare



23 cm  
 für offene Eingriffe  
 for open surgery  
 para intervenciones abiertas  
 pour les interventions ouvertes  
 per interventi a cielo aperto



5

	<b>Système marSeal5 plus Maryland Instrument, complet*, sans lames</b>	<b>Sistema marSeal5 plus Maryland Strumento, completo*, senza lame</b>
80-633-03-04	marSeal5 plus Maryland IQ longueur de tige 230 mm	marSeal5 plus Maryland IQ lunghezza guaina 230 mm
	<b>Composants individuels</b>	<b>Componenti singoli</b>
80-633-04-04	Poignée	Impugnatura
80-633-08-04	Tige tubulaire, Ø 5 mm, longueur de tige 230 mm, composée d'un tube externe et interne**	Stelo tubulaire, Ø 5 mm, lunghezza guaina 230 mm, composto da tubo esterno ed interno**
	<b>Consommables</b>	<b>Materiale di consumo</b>
80-633-10-04	Porte-lame, 230 mm, <b>stérile</b> , UV=10 pièces	Portalama, 230 mm, <b>sterile</b> , UV=10 pezzi
80-633-14-04	Porte-lame, 230 mm, non-stérile, UV=10 pièces	Portalama, 230 mm, non sterile, UV=10 pezzi
	<b>Outils de nettoyage et de préparation</b>	<b>Strumenti di pulizia e condizionamento</b>
80-633-12-04	Outil de nettoyage	Untensile di pulizia
80-633-13-04	Adaptateur de rinçage pour tige tubulaire externe et interne	Adattatore di lavaggio per tubo esterno ed interno

\* incl. 80-633-12-04, 80-633-13-04  
 \*\* incl. 80-633-12-04  
 Les lames doivent être commandées séparément

\* incl. 80-633-12-04, 80-633-13-04  
 \*\* incl. 80-633-12-04  
 Le lame devono essere ordinate a parte

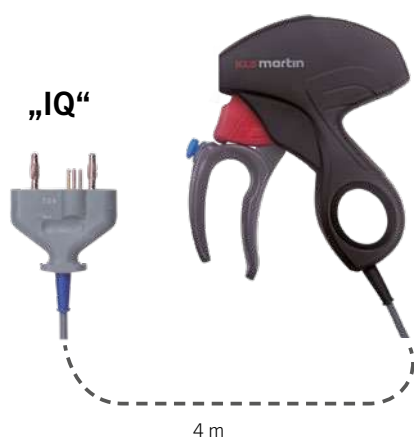

Weitere Informationen entnehmen Sie bitte der separaten Broschüre.  
 For further information please refer to our separate product brochure.  
 Encontrará informaciones adicionales en el folleto individual.  
 Vous trouverez des informations supplémentaires dans la brochure.  
 Per ulteriori informazioni vedasi il prospetto separato.



Lagerung zur Reinigung und Sterilisation der Versiegelungsinstrumente  
Storage for cleaning and sterilization of sealing instruments  
Almacenamiento para la limpieza y esterilización de los instrumentos de sellado  
Conservation en vue du nettoyage et de la stérilisation des instruments de scellement  
Posizionamento per la pulizia e la sterilizzazione degli strumenti di sigillatura

Für die Reinigung und Sterilisation kann zusätzlich das entsprechende Tray verwendet werden. Dieses Tray kann optional bestellt werden.

The corresponding tray can also be used for cleaning and sterilization. This tray can be ordered as an optional extra.

Para la limpieza y esterilización se puede utilizar adicionalmente la bandeja correspondiente. Esta bandeja se puede encargar opcionalmente.

Il est possible en supplément d'utiliser le plateau correspondant pour le nettoyage et la stérilisation. Ce plateau peut être commandé de manière facultative.

Per la pulizia e la sterilizzazione è possibile utilizzare anche il corrispondente vassoio. Il vassoio è ordinabile a richiesta.



55-803-71-04

530 x 250 x 60 mm

Lagerungstray marSeal5 plus, mit Deckel

Storing tray marSeal5 plus, with lid

Tray para depositar marSeal5 plus, con tapa

Plateau pour déposer instruments marSeal5 plus, avec couvercle

Bacinella per mettere strumenti marSeal5 plus, con coperchio



55-803-73-04

530 x 250 x 60 mm

Lagerungstray marSeal5 IQ, mit Deckel

Storing tray marSeal5 IQ, with lid

Tray para depositar marSeal5 IQ, con tapa

Plateau pour déposer instruments marSeal5 IQ, avec couvercle

Bacinella per mettere strumenti marSeal5 IQ, con coperchio

Die Instrumente sind nicht im Lieferumfang enthalten und müssen separat bestellt werden.

The instruments are not included in the scope of supply and therefore must be ordered separately.

Los instrumentos no forman parte de las prestaciones del suministro, debiéndolos encargar por separado.

Les instruments ne sont pas comprises dans la livraison et doivent être commandées séparément.

I strumenti non sono compresi nella fornitura e devono essere ordinati separatamente.



55-803-74-04

530 x 250 x 60 mm

Lagerungstray marSeal/marSeal slim IQ, mit Deckel

Storing tray marSeal/marSeal slim IQ, with lid

Tray para depositar marSeal/marSeal slim IQ, con tapa

Plateau pour déposer marSeal/marSeal slim IQ, avec couvercle

Bacinella per mettere marSeal/marSeal slim IQ, con coperchio



55-803-75-04

280 x 170 x 40 mm

Lagerungstray marClamp® Cut IQ, mit Deckel

Storing tray marClamp® Cut IQ, with lid

Tray para depositar marClamp® Cut IQ, con tapa

Plateau pour déposer instruments marClamp® Cut IQ, avec couvercle

Bacinella per mettere strumenti marClamp® Cut IQ, con coperchio

Die Instrumente sind nicht im Lieferumfang enthalten und müssen separat bestellt werden.  
The instruments are not included in the scope of supply and therefore must be ordered separately.  
Los instrumentos no forman parte de las prestaciones del suministro, debiéndolos encargar por separado.  
Les instruments ne sont pas comprises dans la livraison et doivent être commandés séparément.  
I strumenti non sono compresi nella fornitura e devono essere ordinati separatamente.

Anschlusskabel und Adapter  
Connection cables and adapters  
Cables de conexión y adaptadores  
Câbles de raccordement et adaptateurs  
Cavi di connessione e adattatori

# 6



max. 4000 V<sub>p</sub>



80-289-40-04

4 m

KLS-Martin-Geräte

→ Instrumente mit 3-mm-Stecker (Olympus)

KLS Martin units

→ instruments with 3-mm plug (Olympus)

Equipos de KLS Martin

→ instrumentos con clavija de 3 mm (Olympus)

Appareils KLS Martin

→ instruments avec fiche de 3 mm (Olympus)

Apparecchi di KLS Martin

→ strumenti con spina da 3 mm (Olympus)



83-120-50-04

5 m

KLS-Martin-Geräte

→ Instrumente mit 4-mm-Stecker

KLS Martin units

→ instruments with 4-mm plug

Equipos de KLS Martin

→ instrumentos con clavija de 4 mm

Appareils KLS Martin

→ instruments avec fiche de 4 mm

Apparecchi di KLS Martin

→ strumenti con spina da 4 mm



80-285-40-04

4 m

KLS-Martin-Geräte

→ für Isolit-Pinzetten

KLS Martin units

→ for Isolit forceps

Aparatos KLS Martin

→ para pinzas Isolit

Appareils KLS Martin

→ pour des pinces Isolit

Apparecchi KLS Martin

→ per pinze Isolit

80-285-50-04

5 m



80-289-42-04

4 m

maXium®e/-smart C e und Erbe-, ICC-, ACC- und VIO-Geräte

→ instrumente mit 3-mm-Anschluss (Olympus)

maXium®e/-smart C e and Erbe, ICC, ACC and VIO units

→ instruments with 3-mm socket (Olympus)

maXium®e/-smart C e y Erbe, ICC, ACC y VIO

→ instrumentos con conexión de Ø 3 mm (Olympus)

maXium®e/-smart C e et Erbe, ICC, ACC et VIO

→ instruments avec prise de Ø 3 mm (Olympus)

maXium®e/-smart C e e Erbe, ICC, ACC e VIO

→ strumenti con presa da Ø 3 mm (Olympus)



83-122-60-04

6 m

maXium®e/-smart C e und Erbe-, ICC-, ACC- und VIO-Geräte

→ instrumente mit 4-mm-Anschluss

maXium®e/-smart C e and Erbe, ICC, ACC and VIO units

→ instruments with 4-mm socket

maXium®e/-smart C e y Erbe, ICC, ACC y VIO

→ instrumentos con conexión de Ø 4 mm

maXium®e/-smart C e et Erbe, ICC, ACC et VIO

→ instruments avec prise de Ø 4 mm

maXium®e/-smart C e e Erbe, ICC, ACC e VIO

→ strumenti con presa da Ø 4 mm



83-122-50-04

5 m

Erbotom-Geräte

→ instrumente mit 4-mm-Anschluss

Erbotom electrosurgery units

→ instruments with 4-mm socket

Aparatos Erbotom

→ instrumentos con conexión de Ø 4 mm

Appareils Erbotom

→ instruments avec prise de Ø 4 mm

Apparecchi Erbotom

→ strumenti con presa da Ø 4 mm



max. 4000 V<sub>p</sub>

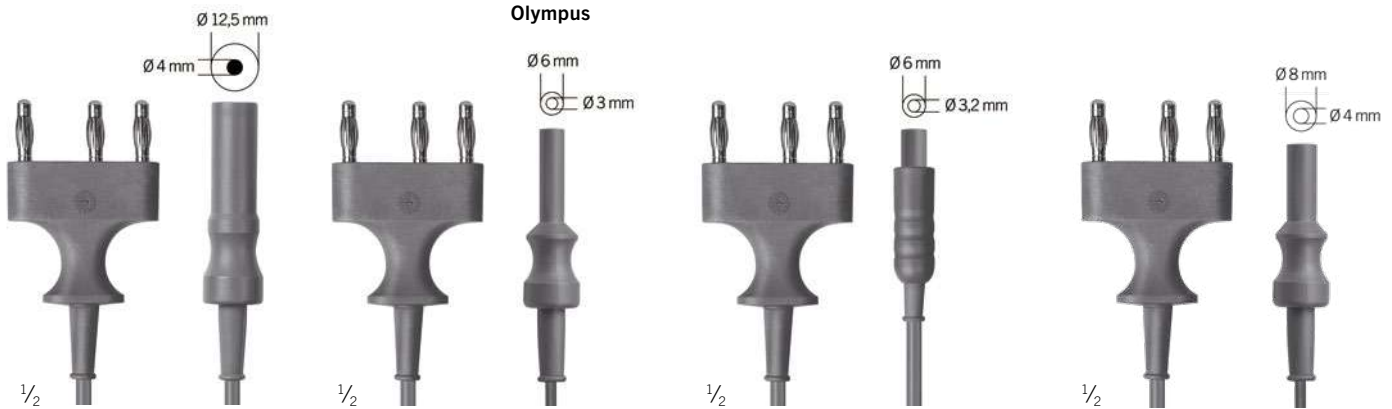

80-285-55-04

4 m  
 mit 3-Pin-Stecker  
 → für Isolit-Pinzetten  
 with 3-pin plug  
 → for Isolit forceps  
 con clavija de 3 patillas  
 → para pinzas Isolit  
 avec fiche à 3-broches  
 → pour des pinces Isolit  
 con spina a 3-spire  
 → per pinze Isolit

80-289-41-04

4 m  
 mit 3-Pin-Stecker → Instrumente  
 mit 3-mm-Stecker (Olympus)  
 with 3-pin plug → instruments  
 with 3-mm plug (Olympus)  
 con clavija de 3 patillas → instrumentos  
 con clavija de Ø 3 mm (Olympus)  
 avec fiche à 3-broches → instruments  
 avec fiche de Ø 3 mm (Olympus)  
 con spina a 3-spire → strumenti  
 con spina da Ø 3 mm (Olympus)

80-290-40-04

4 m  
 KLS-Martin-Geräte  
 → Instrumente mit 3,2-mm-Stecker  
 KLS Martin units  
 → instruments with 3.2-mm plug  
 Aparatos KLS Martin  
 → instrumentos con clavija de Ø 3,2 mm  
 Appareils KLS Martin  
 → instruments avec fiche de Ø 3,2 mm  
 Apparecchi KLS Martin  
 → strumenti con spina da Ø 3,2 mm

83-120-51-04

5 m  
 3-Pin-Stecker  
 → Instrumente mit 4-mm-Stecker  
 3-pin plug  
 → instruments with 4-mm plug  
 Clavija de 3 patillas  
 → instrumentos con clavija de Ø 4 mm  
 Fiche à 3-broches  
 → instruments avec fiche de Ø 4 mm  
 Spina a 3-spire  
 → strumenti con spina da Ø 4 mm

6



83-124-50-04

5 m  
 maXium® i-smart Ci, ME MB 3 i, ME MB 2 i und Valleylab-Geräte  
 → MIC-Instrumente mit 4-mm-Anschluss  
 maXium® i-smart Ci, ME MB 3 i, ME MB 2 i and Valleylab units  
 → MIS instruments with 4-mm socket  
 maXium® i-smart Ci, ME MB 3 i, ME MB 2 i y aparatos Valleylab  
 → instrumentos para la cirugía mínima invasiva con conexión de Ø 4 mm  
 maXium® i-smart Ci, ME MB 3 i, ME MB 2 i et appareils Valleylab  
 → instruments pour la chirurgie non-invasive avec prise de Ø 4 mm  
 maXium® i-smart Ci, ME MB 3 i, ME MB 2 i e apparecchi Valleylab  
 → strumenti per la chirurgia mininvasiva con presa da Ø 4 mm



83-124-52-04

4 m  
 maXium® i-smart Ci, ME MB 3 i, ME MB 2 i und  
 Valleylab-Geräte → für Isolit-Pinzetten  
 maXium® i-smart Ci, ME MB 3 i, ME MB 2 i and  
 Valleylab units → for Isolit forceps  
 maXium® i-smart Ci, ME MB 3 i, ME MB 2 i y  
 aparatos Valleylab → para pinzas Isolit  
 maXium® i-smart Ci, ME MB 3 i, ME MB 2 i et  
 appareils Valleylab → pour des pinces Isolit  
 maXium® i-smart Ci, ME MB 3 i, ME MB 2 i e  
 apparecchi Valleylab → per pinze Isolit

NON-CE



80-280-30-04

3 m  
 Anschlusskabel, einpolig,  
 für Griff 80-213-01-04  
 Connection cable, monopolar,  
 for handle 80-213-01-04  
 Cable de conexión, monopolar,  
 para mango 80-213-01-04  
 Câble de raccordement, monopolaire,  
 pour manche 80-213-01-04  
 Cavo di connessione, monopolare,  
 per manico 80-213-01-04

max. 4000 V<sub>p</sub>



80-286-94-04  
 4 m  
 3-Pin-Stecker  
 → Olympus-Resektoskope  
 3-pin plug  
 → Olympus resectoscopes  
 Clavija de 3 patillas  
 → resectoscopios Olympus  
 Fiche à 3-broches  
 → résectoscopes Olympus  
 Spina a 3-spire  
 → resettoscopi Olympus



80-286-95-04  
 4 m  
 3-Pin-Stecker  
 → Richard-Wolf-Resektoskope  
 3-pin plug  
 → Richard Wolf resectoscopes  
 Clavija de 3 patillas  
 → resectoscopios Richard Wolf  
 Fiche à 3-broches  
 → résectoscopes Richard Wolf  
 Spina a 3-spire  
 → resettoscopi Richard Wolf



80-286-96-04  
 4 m  
 3-Pin-Stecker  
 → Karl-Storz-Resektoskope  
 3-pin plug  
 → Karl Storz resectoscopes  
 Clavija de 3 patillas  
 → resectoscopios Karl Storz  
 Fiche à 3-broches  
 → résectoscopes Karl Storz  
 Spina a 3-spire  
 → resettoscopi Karl Storz



80-287-33-04 80-287-53-04 **max. 600 V<sub>p</sub>**  
 3 m 5 m

KLS-Martin-, Berchtold- und Aesculap-Geräte  
 → bipolare Instrumente  
 KLS Martin, Berchtold and Aesculap units  
 → bipolar instruments  
 Aparatos KLS Martin, Berchtold y Aesculap  
 → instrumentos bipolares  
 Appareils KLS Martin, Berchtold y Aesculap  
 → instruments bipolaires  
 Apparecchi KLS Martin, Berchtold e Aesculap  
 → strumenti bipolari



80-287-60-04 **max. 600 V<sub>p</sub>**  
 4 m

KLS-Martin-, Berchtold- und Aesculap-Geräte  
 → bipolare Instrumente  
 KLS Martin, Berchtold and Aesculap units  
 → bipolar instruments  
 Aparatos KLS Martin, Berchtold y Aesculap  
 → instrumentos bipolares  
 Appareils KLS Martin, Berchtold y Aesculap  
 → instruments bipolaires  
 Apparecchi KLS Martin, Berchtold e Aesculap  
 → strumenti bipolari



80-287-42-04 **max. 600 V<sub>p</sub>**  
 3 m

KLS-Martin-Geräte  
 → Storz bipolare Instrumente  
 KLS Martin units  
 → Storz bipolar instruments  
 Aparatos KLS Martin  
 → instrumentos bipolares Storz  
 Appareils KLS Martin  
 → instruments bipolaires Storz  
 Apparecchi KLS Martin  
 → strumenti bipolari Storz

6



80-285-51-04 **max. 500 V<sub>p</sub>**  
 4 m

KLS-Martin-Geräte  
 → Storz-Endoskope  
 KLS Martin units  
 → Storz endoscopes  
 Aparatos KLS Martin/  
 → endoscopios Storz  
 Appareils KLS Martin/  
 → endoscopes Storz  
 Apparecchi KLS Martin/  
 → endoscopi Storz



80-288-53-04 **max. 600 V<sub>p</sub>**  
 5 m

KLS-Martin-Geräte  
 → Valleylab bipolare Pinzetten  
 KLS Martin units  
 → Valleylab bipolar forceps  
 Aparatos KLS Martin  
 → pinzas bipolares Valleylab  
 Appareils KLS Martin  
 → pinces bipolaires Valleylab  
 Apparecchi KLS Martin  
 → pinze bipolari Valleylab



80-288-55-04 **max. 600 V<sub>p</sub>**  
 5 m

KLS-Martin-Geräte  
 → bipolare Scheren von Ethicon (PowerStar)  
 KLS Martin units  
 → bipolar scissors made by Ethicon (PowerStar)  
 Aparatos KLS Martin  
 → tijeras bipolares de Ethicon (PowerStar)  
 Appareils KLS Martin  
 → ciseaux bipolaires de Ethicon (PowerStar)  
 Apparecchi KLS Martin,  
 → forbici bipolari di marca Ethicon (PowerStar)

max. 600 V<sub>p</sub>



80-286-30-04 80-286-50-04  
 3 m 5 m

maXium® e/-smart Ce / Erbe-Geräte ICC und ACC/VIO  
 → bipolare Instrumente  
 maXium® e/-smart Ce / ICC and ACC/VIO Erbe units  
 → bipolar instruments  
 maXium® e/-smart Ce / aparatos Erbe ICC e ACC/VIO  
 → instrumentos bipolares  
 maXium® e/-smart Ce / appareils Erbe ICC et ACC/VIO  
 → instruments bipolaires  
 maXium® e/-smart Ce / apparecchi Erbe ICC e ACC/VIO  
 → strumenti bipolari



80-286-60-04  
 4 m

maXium® e/-smart Ce / Erbe-Geräte ICC und ACC/VIO  
 → bipolare Instrumente  
 maXium® e/-smart Ce / ICC and ACC/VIO Erbe units  
 → bipolar instruments  
 maXium® e/-smart Ce / aparatos Erbe ICC e ACC/VIO  
 → instrumentos bipolares  
 maXium® e/-smart Ce / appareils Erbe ICC et ACC/VIO  
 → instruments bipolaires  
 maXium® e/-smart Ce / apparecchi Erbe ICC e ACC/VIO  
 → strumenti bipolari

NON-CE



80-287-70-04  
 5 m

Codman- und Valleylab-Geräte  
 → bipolare Instrumente  
 Codman and Valleylab units  
 → bipolar instruments  
 Aparatos Codman y Valleylab  
 → instrumentos bipolares  
 Appareils Codman et Valleylab  
 → instruments bipolaires  
 Apparecchi Codman e Valleylab  
 → strumenti bipolari



80-287-72-04  
 5 m

Codman- und Valleylab-Geräte  
 → bipolare Instrumente  
 Codman and Valleylab units  
 → bipolar instruments  
 Aparatos Codman y Valleylab  
 → instrumentos bipolares  
 Appareils Codman et Valleylab  
 → instruments bipolaires  
 Apparecchi Codman e Valleylab  
 → strumenti bipolari

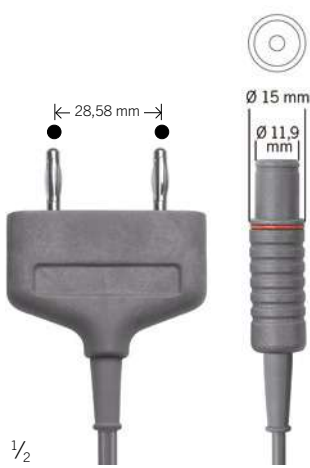

80-287-44-04  
 3 m

Geräte mit 2-Pin-International  
 → Storz bipolare Instrumente  
 Units with 2-pin international  
 → Storz bipolar instruments  
 Equipos con 2 alfileres, internacional  
 → instrumentos bipolares Storz  
 Appareils à 2 broches, international  
 → instruments bipolaires Storz  
 Apparecchi a 2 pin, internazionale  
 → strumenti bipolari Storz

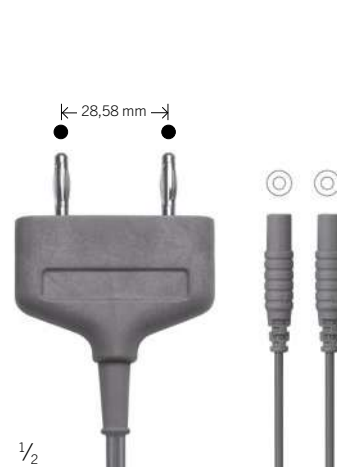

80-288-57-04  
 5 m

Geräte mit 2-Pin-International  
 → bipolare Scheren von Ethicon (PowerStar)  
 Units with 2-pin international  
 → bipolar scissors made by Ethicon (PowerStar)  
 Equipos con 2 alfileres, internacional  
 → tijeras bipolares de Ethicon (PowerStar)  
 Appareils à 2 broches, international  
 → ciseaux bipolaires de Ethicon (PowerStar)  
 Apparecchi a 2 pin, internazionale  
 → forbici bipolari di marca Ethicon (PowerStar)





max. 600 V<sub>p</sub>



80-287-80-04

4 m

KLS-Martin-, Berchtold- und Aesculap-Geräte  
 → Aesculap bipolare Instrumente

KLS Martin, Berchtold and Aesculap units  
 → Aesculap bipolar instruments

Aparatos KLS Martin, Berchtold y Aesculap  
 → instrumentos bipolares Aesculap

Appareils KLS Martin, Berchtold y Aesculap  
 → instruments bipolaires Aesculap

Apparecchi KLS Martin, Berchtold e Aesculap  
 → strumenti bipolari Aesculap

80-286-80-04

4 m

maXium® e/-smart Ce / Erbe-Geräte ICC und ACC/VIO  
 → Aesculap bipolare Instrumente

maXium® e/-smart Ce / ICC and ACC/VIO Erbe units  
 → Aesculap bipolar instruments

maXium® e/-smart Ce / aparatos Erbe ICC e ACC/VIO  
 → instrumentos bipolares Aesculap

maXium® e/-smart Ce / appareils Erbe ICC et ACC/VIO  
 → instruments bipolaires Aesculap

maXium® e/-smart Ce / apparecchi Erbe ICC e ACC/VIO  
 → strumenti bipolari Aesculap

80-288-80-04

4 m

Geräte mit 2-Pin-International  
 → Aesculap bipolare Instrumente

Units with 2-pin international  
 → Aesculap bipolar instruments

Equipos con 2 alfileres, internacional  
 → instrumentos bipolares Aesculap

Appareils à 2 broches, international  
 → instruments bipolaires Aesculap

Apparecchi a 2 pin, internazionale  
 → strumenti bipolari Aesculap

6



80-287-89-04

3 m

maXium® i/-smart Ci / ME MB 3 i, ME MB 2 i /Valleylab-Geräte  
 → bipolare Instrumente

maXium® i/-smart Ci / ME MB 3 i, ME MB 2 i /Valleylab units  
 → bipolar instruments

maXium® i/-smart Ci / ME MB 3 i, ME MB 2 i /aparatos Valleylab  
 → instrumentos bipolares

maXium® i/-smart Ci / ME MB 3 i, ME MB 2 i /appareils Valleylab  
 → instruments bipolaires

maXium® i/-smart Ci / ME MB 3 i, ME MB 2 i /apparecchi Valleylab  
 → strumenti bipolari

80-287-90-04

5 m

80-288-60-04

4 m

maXium® i/-smart Ci / ME MB 3 i, ME MB 2 i /Valleylab-Geräte  
 → bipolare Instrumente

maXium® i/-smart Ci / ME MB 3 i, ME MB 2 i /Valleylab units  
 → bipolar instruments

maXium® i/-smart Ci / ME MB 3 i, ME MB 2 i /aparatos Valleylab  
 → instrumentos bipolares

maXium® i/-smart Ci / ME MB 3 i, ME MB 2 i /appareils Valleylab  
 → instruments bipolaires

maXium® i/-smart Ci / ME MB 3 i, ME MB 2 i /apparecchi Valleylab  
 → strumenti bipolari

Anschlusskabel für bipolare Resektoskope  
 Connection cables for bipolar resectoscopes  
 Cables de conexión para resectoscopios bipolares  
 Câbles de raccordement pour résectoscopes bipolaires  
 Cavi di connessione per resettoscopi bipolari

maXium®

Nur verwendbar mit maXium® (ab HW06), sowie Option „Bipolare Resektion“ Art-Nr. 80-093-00-04  
 Can be used only with maXium® units (HW06 or higher) and “Bipolar Resection” option, item no. 80-093-00-04  
 Sólo puede utilizarse con equipos maXium® (a partir del hardware 06 o superior) y la opción “Resección bipolar”, n.º ref. 80-093-00-04  
 Utilisable uniquement avec maXium® (à partir de la version matérielle 06) et avec l'option « Résection bipolaire » réf. 80-093-00-04  
 Utilizzabile solo con l'apparecchio maXium® (versione HW06 o superiore) e con l'opzione “Resezione bipolare”, codice art. 80-093-00-04



max. 600 V<sub>p</sub>

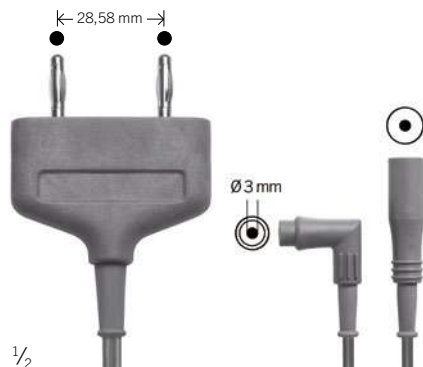

80-287-94-04

- 4 m
- maXium® m/i/e
- bipolares Resektoskop Olympus
- maXium® m/i/e
- bipolar Olympus resectoscope
- maXium® m/i/e
- resectoscopio bipolar Olympus
- maXium® m/i/e
- résectoscope bipolaire Olympus
- maXium® m/i/e
- resettoscopio bipolare Olympus



80-287-96-04

- 4 m
- maXium® m/i/e
- bipolares Resektoskop Karl Storz
- maXium® m/i/e
- bipolar Karl Storz resectoscope
- maXium® m/i/e
- resectoscopio bipolar Karl Storz
- maXium® m/i/e
- résectoscope bipolaire Karl Storz
- maXium® m/i/e
- resettoscopio bipolare Karl Storz

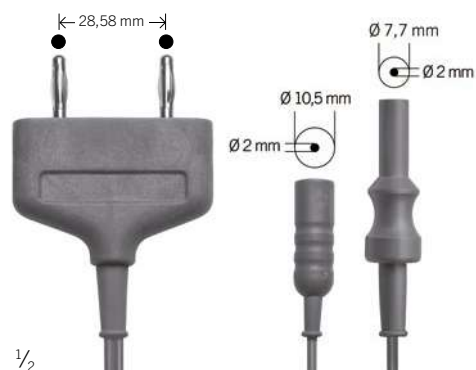

80-287-95-04

- 4 m
- maXium® m/i/e
- bipolares Resektoskop Richard Wolf
- maXium® m/i/e
- bipolar Richard Wolf resectoscope
- maXium® m/i/e
- resectoscopio bipolar Richard Wolf
- maXium® m/i/e
- résectoscope bipolaire Richard Wolf
- maXium® m/i/e
- resettoscopio bipolare Richard Wolf



80-251-00-04 **max700 V<sub>p</sub>**

Monopolarer Adapter für KLS-Martin-Geräte und Bovie-Zubehör

Monopolar adapter for KLS Martin units and Bovie accessories

Adaptador monopolar para aparatos KLS Martin y accesorios Bovie

Adaptateur monopolaire pour appareils KLS Martin et accessoires Bovie

Adattatore monopolare per apparecchi KLS Martin ed accessori Bovie

**NON-CE**



80-795-04-04 **max. 4000 V<sub>p</sub>**

Monopolarer Adapter mit Bovie-Stecker  
Für Anschlussstecker 2-4 mm (1-polig)

Monopolar adapter with Bovie connector  
For 2-4 mm cable connectors (1-pole)

Adaptador monopolar con clavija Bovie  
Para clavijas de conexión de 2-4 mm (1 polo)

Adaptateur monopolaire avec connecteur Bovie  
Pour connecteur 2-4 mm (1 pôle)

Adattatore monopolare con connettore Bovie  
Per connettore 2-4 mm (1 polo)



80-795-03-04 **max. 4000 V<sub>p</sub>**

Monopolares Adapterkabel für Erbe-Geräte (ICC, ACC, VIO) und KLS-Martin-Zubehör

Monopolar adapter cable for Erbe units (ICC, ACC, VIO) and KLS Martin accessories

Cable adaptador monopolar para equipos Erbe (ICC, ACC, VIO) y accesorios de KLS Martin

Câble d'adaptateur monopolaire pour appareils Erbe (ICC, ACC, VIO) et accessoires KLS Martin

Cavo adattatore monopolare per apparecchi Erbe (ICC, ACC, VIO) e accessori KLS Martin

max. 700 V<sub>p</sub>



80-795-02-04

Bipolarer Adapter für KLS-Martin-Geräte und Erbe-Zubehör  
Bipolar adapter for KLS Martin units and Erbe accessories  
Adaptador bipolar para aparatos KLS Martin y accesorios Erbe  
Adaptateur bipolaire pour appareils KLS Martin et accessoires Erbe  
Adattatore bipolare per apparecchi KLS Martin ed accessori Erbe



80-793-02-04

25 cm/10"  
Bipolares Adapterkabel für KLS-Martin-Geräte  
→ Codman-/Valleylab-Instrumente  
Bipolar adapter cable for KLS Martin units  
→ Codman/Valleylab instruments  
Cable adaptador bipolar para aparatos KLS Martin  
→ instrumentos Codman/Valleylab  
Câble adaptateur bipolaire pour appareils KLS Martin  
→ instruments Codman/Valleylab  
Cavo adattatore bipolare per apparecchi KLS Martin  
→ strumenti Codman/Valleylab



max. 700 V<sub>p</sub>



1/2

80-794-02-04

Bipolarer Adapter für KLS-Martin-Geräte („i“-Version) und Valleylab-Zubehör

Bipolar adapter for KLS Martin units (“i“-version) and Valleylab accessories

Adaptador bipolar para aparatos KLS Martin (versión “i“) y accesorios Valleylab

Adaptateur bipolaire pour appareils KLS Martin (version «i») et accessoires Valleylab

Adattatore bipolare per apparecchi KLS Martin (versione “i“) ed accessori Valleylab



1/2

80-796-03-04

Adapter für Neutralelektrode mit I-Stecker 6,3 mm-NE-Buchse

Adapter for neutral electrode with I-plug, for 6.3-mm NE socket

Adaptador para placa neutra con clavija I, para hembra de PN de 6,3 mm

Adaptateur pour électrode neutre avec connecteur I, pour fiche EN 6,3 mm

Adattatore per elettrodo neutro con spina I, per presa EN da 6,3 mm

Ab Hardware 06 und Software V 3.394  
From hardware 06 and software V3.394  
A partir del hardware 06 y del software V3.394  
À partir de la version matérielle 06 et de la version logicielle V3.394  
A partire dalla versione hardware 06 e dalla versione software V3.394

max. 2500 V<sub>p</sub>

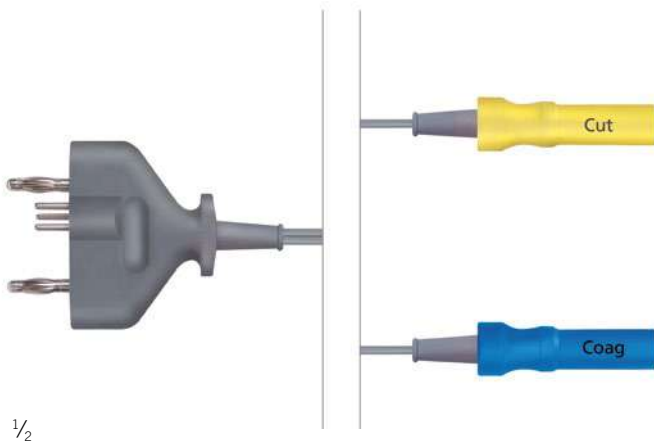

80-790-00-04

Bipolarer Port-Expander für maXium®, Version KLS Martin (ab Hardware 06 und Software V3.394), zum Anschluss von zwei Instrumentenkabeln mit KLS-Martin-Stecker  
Bipolar port expander for maXium®, KLS Martin version (hardware 06 and software V3.394, or higher), for connecting two bipolar instrument cables with KLS Martin plug  
Expansor de puerto bipolar para maXium®, versión “KLS Martin” (a partir del hardware 06 y del software V3.394, o superior), para la conexión de dos cables bipolares de instrumento con clavija KLS Martin  
Expandeur de port bipolaire pour maXium® version «KLS Martin» (à partir de la version matérielle 06 et de la version logicielle V3.394), pour le raccordement de deux câbles d’instruments bipolaires avec fiches de KLS Martin  
Espansore di porta bipolare per maXium® versione “KLS Martin” (a partire dalla versione hardware 06 e dalla versione software V3.394), per il collegamento di due cavi per strumenti bipolari spine KLS Martin

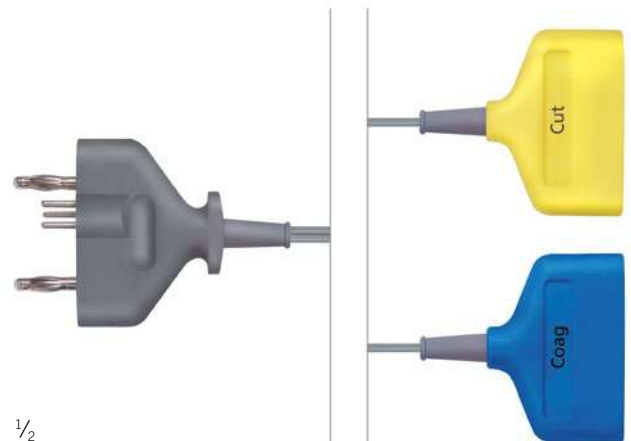

80-790-01-04

Bipolarer Port-Expander für maXium®, Version „international“ (ab Hardware 06 und Software V3.394), zum Anschluss von zwei bipolaren Instrumentenkabeln mit i-Steckern  
Bipolar port expander for maXium®, international version (hardware 06 and software V3.394, or higher), for connecting two bipolar instrument cables with i plugs  
Expansor de puerto bipolar para maXium®, versión “internacional” (a partir del hardware 06 y del software V3.394, o superior), para la conexión de dos cables de instrumento bipolares con clavijas de i  
Expandeur de port bipolaire pour maXium®, version «international» (à partir de la version matérielle 06 et de la version logicielle V3.394), pour le raccordement de deux câbles d’instruments bipolaires avec fiches de i  
Espansore di porta bipolare per maXium®, versione “internazionale” (a partire dalla versione hardware 06 e dalla versione software V3.394), per il collegamento di due cavi per strumenti bipolari con spine da i

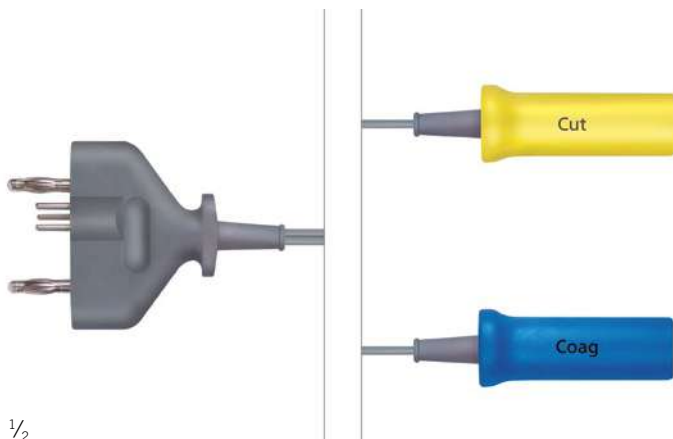

1/2

#### 80-790-02-04





















Bipolarer Port-Expander für maXium®, Version Erbe (ab Hardware 06 und Software V3.394), zum Anschluss von zwei bipolaren Instrumentenkabeln mit Erbe-Stecker  
 Bipolar port expander for maXium®, Erbe version (hardware 06 and software V3.394, or higher), for connecting two bipolar instrument cables with Erbe plugs  
 Expansor de puerto bipolar para maXium®, versión "Erbe" (a partir del hardware 06 y del software V3.394, o superior), para la conexión de dos cables de instrumento bipolares con clavijas Erbe  
 Expanseur de port bipolaire pour maXium®, version «Erbe» (à partir de la version matérielle 06 et de la version logicielle V3.394), pour le raccordement de deux câbles d'instruments bipolaires avec fiches de Erbe  
 Espansore di porta bipolare per maXium®, versione "Erbe" (a partire dalla versione hardware 06 e dalla versione software V3.394), per il collegamento di due cavi per strumenti bipolari con spine Erbe



6

#### 80-800-00-04















Kabelmarkierung autoklavierbar, Set bestehend aus drei Farben (gelb, grün, rot)  
 Cable markers, autoclavable, set including three colors (yellow, green, red)  
 Marca de cable, autoclavable, juego compuesto de tres colores diferentes (amarillo, verde, rojo)  
 Marquage pour câbles, autoclavable, set comprenant trois couleurs (jaune, vert, rouge)  
 Contrassegno per cavo, autoclavabile, set costituito da tre colori diversi (giallo, verde, rosso)

<p><b>Geräte</b>  <b>Units</b>  <b>Equipos</b>  <b>Appareils</b>  <b>Apparecchi</b></p>		<p>Olympus</p>			<p>einpolig                      monopole                      unipolar                      monopolaire                      monopolare</p>
<p>KLS Martin                      Berchtold                      Aesculap</p>  		  <p>1/3</p>	 	 	 
<p>maXium® e                      Erbe ICC                      Erbe ACC                      Erbe VIO</p>  		<p>80-289-40-04                      4                      max. 4000 V<sub>p</sub></p>	<p>83-120-50-04                      5 m                      max. 4000 V<sub>p</sub></p>		
<p>Erbotom</p>  			<p>83-122-50-04                      5 m                      max. 4000 V<sub>p</sub></p>		
<p>3-Pin                      maXium®                      ME MB 3 i                      ME MB 2 i</p> 		<p>80-289-41-04                      4 m                      max. 4000 V<sub>p</sub></p>	<p>83-120-51-04                      5 m                      max. 4000 V<sub>p</sub></p>	<p>80-290-40-04                      4 m                      max. 4000 V<sub>p</sub></p>	
<p>maXium®                      ME MB 3 i                      ME MB 2 i                      Valleylab</p>  			<p>83-124-50-04                      5 m                      max. 4000 V<sub>p</sub></p>		
<p>einpolig                      monopole                      unipolar                      monopolaire                      monopolare  <b>NON-CE</b></p>  					<p>80-280-30-04                      3 m                      max. 4000 V<sub>p</sub></p>
<p>KLS Martin                      Isolit-Pinzetten                      Isolit forceps                      Pinzas Isolit                      Pinces Isolit                      Pinze Isolit</p>  					





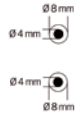





<p>KLS Martin</p> <p>Isolit-Pinzetten                      Isolit forceps                      Pinzas Isolit                      Pincas Isolit                      Pinze Isolit</p> 	<p>Olympus</p> <p>Monopolares Resektoskop                      Monopolar resectoscope                      Resectoscopio monolar                      Résectoscope monopolaire                      Resettoscopio monopolare</p> 	<p>Richard Wolf</p> <p>Monopolares Resektoskop                      Monopolar resectoscope                      Resectoscopio monolar                      Résectoscope monopolaire                      Resettoscopio monopolare</p> 	<p>Karl Storz</p> <p>Monopolares Resektoskop                      Monopolar resectoscope                      Resectoscopio monolar                      Résectoscope monopolaire                      Resettoscopio monopolare</p> 
<p>80-285-55-04                      4 m  <i>max. 4000 V<sub>p</sub></i></p>	<p>80-286-94-04                      4 m  <i>max. 4000 V<sub>p</sub></i></p>	<p>80-286-95-04                      4 m  <i>max. 4000 V<sub>p</sub></i></p>	<p>80-286-96-04                      4 m  <i>max. 4000 V<sub>p</sub></i></p>
<p>83-124-52-04                      4 m  <i>max. 4000 V<sub>p</sub></i></p>			
<p>80-285-40-04                      4 m  <i>max. 4000</i></p> <p>80-285-50-04                      5 m  <i>max. 4000</i></p>			

<p>Geräte Units Equipos Appareils Apparecchi</p>	<p>Instrumente Instruments Instrumentos Instruments Strumenti</p>	<p>Europäischer Flachstecker European flat plug Enchufe plano para Europa Fiche plate européenne Spina piatta europea</p>	<p>Europäischer Flachstecker European flat plug Enchufe plano para Europa Fiche plate européenne Spina piatta europea</p>	<p>Karl Storz</p>
<p>KLS Martin Berchtold Aesculap</p>  	<p>1/3</p> 			
<p>maXium® e Erbe ICC Erbe ACC Erbe VIO</p>  	<p>80-287-33-04 3 m <b>max. 600 V<sub>p</sub></b></p> <p>80-287-53-04 5 m <b>max. 600 V<sub>p</sub></b></p>	<p>80-291-40-04 4 m <b>max. 850 V<sub>p</sub></b></p>	<p>80-287-60-04 4 m <b>max. 600 V<sub>p</sub></b></p>	<p>80-287-42-04 3 m <b>max. 600 V<sub>p</sub></b></p>
<p>maXium® i maXium® e ME MB 2 i ME MB 3 i Valleylab</p>  	<p>80-286-30-04 3 m <b>max. 600 V<sub>p</sub></b></p> <p>80-286-50-04 5 m <b>max. 600 V<sub>p</sub></b></p>	<p>80-286-40-04 4 m <b>max. 850 V<sub>p</sub></b></p>	<p>80-286-60-04 4 m <b>max. 600 V<sub>p</sub></b></p>	<p>80-288-60-04 4 m <b>max. 600 V<sub>p</sub></b></p> <p>80-287-44-04 3 m <b>max. 600 V<sub>p</sub></b></p>
<p>Codman Valleylab</p>  	<p>80-287-72-04 5 m <b>max. 600 V<sub>p</sub></b></p>			
<p>Codman Valleylab <b>NON-CE</b></p>  	<p>80-287-70-04 5 m <b>max. 600 V<sub>p</sub></b></p>			



Karl Storz Endoskope Endoscopes Endoscopios Endoscopes Endoscopi	Aesculap Flachstecker/tab connector Tab connector Conector plano/tab connector Connecteur plat/tab connector Connettole piatto/tab connecto	Valleylab Pinzetten Forceps Pinzas Pincas Pinze	Ethicon (PowerStar) Scheren Scissors Tijeras Ciseaux Forbici	Olympus Bipolares Resektoskop Bipolar resectoscope Resectoscopio bipolar Résectoscope bipolaire Resettoscopio bipolare	Karl Storz Bipolares Resektoskop Bipolar resectoscope Resectoscopio bipolar Résectoscope bipolaire Resettoscopio bipolare	Richard Wolf Bipolares Resektoskop Bipolar resectoscope Resectoscopio bipolar Résectoscope bipolaire Resettoscopio bipolare
 80-285-51-04 4 m max. 600 V <sub>p</sub>	 80-287-80-04 4 m max. 600 V <sub>p</sub>	 80-288-53-04 4 m max. 600 V <sub>p</sub>	 80-288-55-04 5 m max. 600 V <sub>p</sub>	 80-287-94-04 4 m max. 600 V <sub>p</sub>	 80-287-96-04 4 m max. 600 V <sub>p</sub>	 80-287-95-04 4 m max. 600 V <sub>p</sub>
	80-286-80-04 4 m max. 600 V <sub>p</sub>					
	80-288-80-04 4 m max. 600 V <sub>p</sub>		80-288-57-04 5 m max. 600 V <sub>p</sub>			

# 7

Argon-Beamer-System  
Argon Beamer System  
Sistema Argon Beamer  
Système Argon Beamer  
Sistema Argon Beamer



MABS-Handgriff für starre Applikatoren  
MABS handle for rigid applicators  
Mango MABS para aplicadores rígidos  
Manche MABS pour applicateurs rigides  
Manipolo MABS per applicatori rigidi

**MABS – Das KLS-Martin-Argon-Beamer-System**  
**MABS – The KLS Martin Argon Beamer System**  
**MABS – El sistema KLS Martin Argon Beamer**  
**MABS – Le système KLS Martin Argon Beamer**  
**MABS – Il sistema KLS Martin Argon Beamer**



80-181-02-04 **max. 4000 V<sub>p</sub>**

MABS-Handgriff für starre Applikatoren  
Zwei Tasten für Koagulation und Schneiden  
Anschlusskabel 4,5 m für HF-Strom und Argon-Gas  
MABS handle for rigid applicators  
Two pushbuttons for coagulating and cutting  
Connection cable 4.5 m length, for HF current and argon gas  
Mango MABS para aplicadores rígidos  
Dos teclas para la coagulación y el corte  
Cable de conexión de 4,5 m para la corriente AF y el gas argón  
Manche MABS pour applicateurs rigides  
Deux touches pour coagulation et coupe  
Câble de raccordement 4,5 m pour courant HF et gaz d'argon  
Manipolo MABS per applicatori rigidi  
Due pulsanti per taglio e coagulazione  
Cavo di collegamento di 4,5 m per corrente AF e gas argon



80-181-90-04

MABS-Sterilfilter, VE = 50 Stück  
MABS sterile filter, SU = 50/pack  
Filtro estéril MABS, UV = 50 piezas  
Filtre stérile MABS, UC = 50 unités  
Filtro sterile MABS, UV = 50 pezzi



Ø 4 mm  **max. 4000 V<sub>p</sub>**

Die MABS-Elektroden haben folgende gemeinsame Eigenschaften:

- Isolierter, starrer Schaft mit einem Durchmesser von 5 mm
- Distale Keramikdüse
- Hochtemperaturfeste Zündspitze

All MABS electrodes share the following features:

- Insulated, rigid shaft with a diameter of 5 mm
- Distal ceramic nozzle
- High-temperature-resistant ignition tip

Los electrodos del MABS cuentan con las siguientes características funcionales:

- Varilla aislada y rígida con un diámetro de 5 mm
- Inyector de cerámica distal
- Punta de ignición resistente a las altas temperaturas

Les électrodes MABS présentent les performances communes suivantes:

- Tige rigide, isolée, d'un diamètre de 5 mm
- Buse distale en céramique
- Pointe de contact résistant aux températures élevées

Gli elettrodi MABS possiedono le seguenti caratteristiche comuni:

- Asta isolato e rigido con un diametro di 5 mm
- Ugello distale di ceramica
- Punta resistente alle elevate temperature



1/2

#### 80-181-05-04

Fixierkappe und O-Ring, passend für alle starren Elektroden  
 Fixing cap and O-ring, suitable for all rigid electrodes  
 Capuchón de fijación y junta tórica, adecuado para todos los electrodos rígidos  
 Capuchon de fixation et joint torique, pour toutes les électrodes rigides  
 Cappuccio di fissaggio e O-ring, per tutti gli elettrodi rigidi

7



1/2

#### 80-181-10-04

MABS-Beam-Elektrode für die offene Chirurgie  
 Hochtemperaturfeste Zündspitze  
 MABS beam electrode for open surgery  
 High-temperature-resistant ignition tip  
 Electrodo MABS Beam para la cirugía abierta  
 Punta de ignición resistente a las altas temperaturas  
 Electrode MABS Beam pour la chirurgie ouverte  
 Pointe de contact résistant aux températures élevées  
 Elettrodo MABS Beam per la chirurgia aperta  
 Punta resistente alle elevate temperature



1/2

#### 80-181-11-04

MABS-Beam-Elektrode für die offene Chirurgie  
 Hochtemperaturfeste Zündspitze  
 MABS beam electrode for open surgery  
 High-temperature-resistant ignition tip  
 Electrodo MABS Beam para la cirugía abierta  
 Punta de ignición resistente a las altas temperaturas  
 Electrode MABS Beam pour la chirurgie ouverte  
 Pointe de contact résistant aux températures élevées  
 Elettrodo MABS Beam per la chirurgia aperta  
 Punta resistente alle elevate temperature

Ø 4 mm  **max. 4000 V<sub>p</sub>**



**80-181-12-04**

MABS-Beam-Elektrode für die Laparoskopie und Pelviskopie, hochtemperaturfeste Zündspitze, inkl. Fixierkappe

MABS beam electrode for laparoscopy and pelviscopy, high-temperature-resistant ignition tip, incl. fixing cap

Electrodo MABS beam para la laparoscopia y pelviscopia, punta de ignición resistente a las altas temperaturas, incl. capuchón de fijación

Electrode MABS beam pour la laparoscopie et la pelviscopia, pointe de contact résistante aux températures élevées, capuchon de fixation compris

Elettrodo MABS beam per laparoscopia e pelviscopia, punta resistente alle elevate temperature, compreso cappuccio di fissaggio

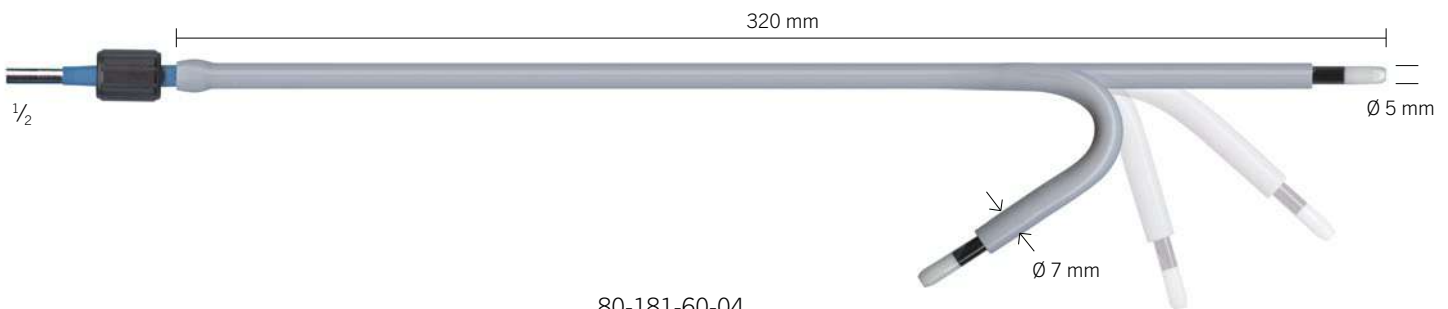

**80-181-60-04**

MABS-Beam-Elektrode, 320 mm, biegsam

MABS beam electrode, 320 mm, flexible

Electrodo MABS beam, 320 mm, flexible

Electrode MABS beam, 320 mm, flexible

Elettrodo MABS beam, 320 mm, flessibile

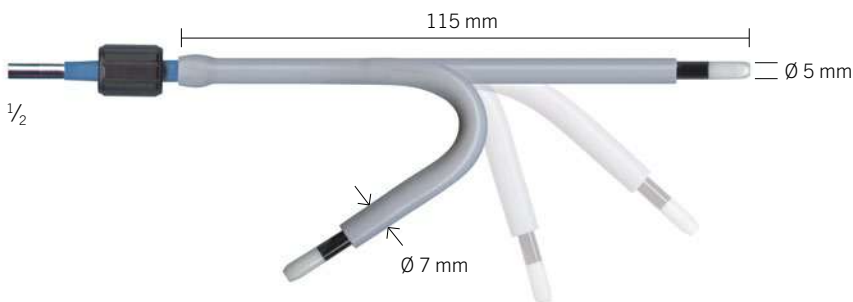

**80-181-62-04**

MABS-Beam-Elektrode, 115 mm, biegsam

MABS beam electrode, 115 mm, flexible

Electrodo MABS beam, 115 mm, flexible

Electrode MABS beam, 115 mm, flexible

Elettrodo MABS beam, 115 mm, flessibile



Ø 4 mm  **max. 4000 V<sub>p</sub>**



80-181-13-04

MABS-Lanzetten-Elektrode für die offene Chirurgie  
 MABS lancet electrode for open surgery  
 Electrodo de lanceta MABS para la cirugía abierta  
 Electrode couteaux MABS pour la chirurgie ouverte  
 Elettrodo a lancetta MABS per la chirurgia aperta



80-181-14-04

MABS-Lanzetten-Elektrode für die offene Chirurgie  
 MABS lancet electrode for open surgery  
 Electrodo de lanceta MABS para la cirugía abierta  
 Electrode couteaux MABS pour la chirurgie ouverte  
 Elettrodo a lancetta MABS per la chirurgia aperta



80-181-15-04

MABS-Nadel-Elektrode für die offene Chirurgie  
 MABS needle electrode for open surgery  
 Electrodo de aguja MABS para la cirugía abierta  
 Electrode aiguille MABS pour la chirurgie ouverte  
 Elettrodo ad ago MABS per la chirurgia aperta



80-181-16-04

MABS-Nadel-Elektrode für die offene Chirurgie  
 MABS needle electrode for open surgery  
 Electrodo de aguja MABS para la cirugía abierta  
 Electrode aiguille MABS pour la chirurgie ouverte  
 Elettrodo ad ago MABS per la chirurgia aperta



80-181-07-04

MABS-Nadel-Elektrode für die offene Chirurgie, verschiebbar  
 MABS needle electrode for open surgery, adjustable  
 Electrodo de aguja MABS para la cirugía abierta, regulable  
 Electrode aiguille MABS pour la chirurgie ouverte, réglable  
 Elettrodo ad ago MABS per la chirurgia aperta, regolabile

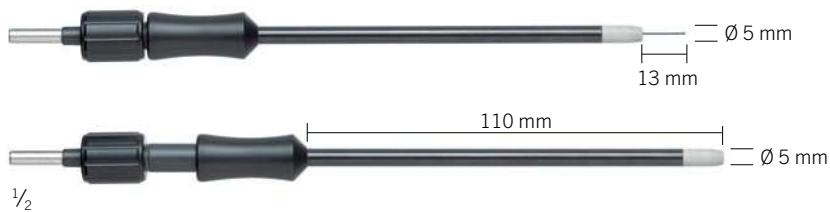

80-181-08-04

MABS-Nadel-Elektrode für die offene Chirurgie, verschiebbar  
 MABS needle electrode for open surgery, adjustable  
 Electrodo de aguja MABS para la cirugía abierta, regulable  
 Electrode aiguille MABS pour la chirurgie ouverte, réglable  
 Elettrodo ad ago MABS per la chirurgia aperta, regolabile



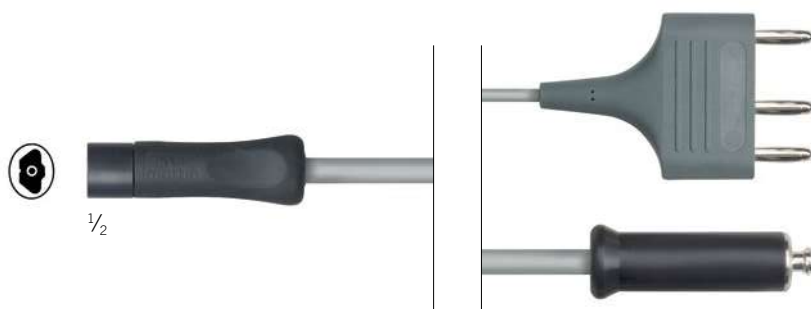

80-181-30-04 **max. 4300 V<sub>p</sub>**

MABS-Anschlussleitung für flexible Sonden (disposable und wiederverwendbar)  
 Anschlusskabel 2,5 m, für HF-Strom und Argongas  
 HF- und Gas-Aktivierung über Fußschalter

MABS connection cable for flexible probes (disposable and reusable)  
 Connection cable, 2.5 m, for HF current and argon gas  
 HF-current and gas-flow activation via foot switch

Línea de conexión MABS para sondas flexibles (desechables y reutilizables)  
 Cable de conexión de 2,5 m, para corriente AF y gas argón  
 Activación AF y del gas por medio del interruptor de pedal

Conduite raccord MABS pour sondes flexibles (à usage unique et réutilisables)  
 Câble de raccordement, 2,5 m, pour courant HF et gaz d'argon  
 Activation HF et gaz par l'intermédiaire d'un interrupteur à pied

Cavo di collegamento MABS per sonde flessibili (monouso e riutilizzabili)  
 Cavo di collegamento, 2,5 m, per corrente AF e gas argon  
 Attivazione AF e gas mediante interruttore a pedale



80-181-90-04

MABS-Sterilfilter, VE = 50 Stück  
 MABS sterile filter, SU = 50/pack  
 Filtro estéril MABS, UV = 50 piezas  
 Filtre stérile MABS, UC = 50 unités  
 Filtro sterile MABS, UV = 50 pezzi



80-181-31-04

MABS-Spüladapter für wiederverwendbare Argon-Sonden, VE = 5 Stück  
 MABS rinsing adapter for reusable argon probes, SU = 5/pack  
 Adaptador de enjuague MABS para sondas argon reutilizables, UV = 5 piezas  
 Adaptateur de rinçage MABS pour sondes argon réutilisables, UC = 5 unités  
 Adattatore di lavaggio MABS per sonde riutilizzabili, UV = 5 pezzi



**MABS flexible Sonden haben folgende gemeinsame Eigenschaften:**

- Distale Keramikdüse
- Skaliertes Sondenende
- Um 50 % reduzierter Gasverbrauch (im Vergleich zu bisherigen Sonden)

**All MABS flexible probes have the following features in common:**

- Distal ceramic nozzle
- Scaled probe tip
- Reduced gas consumption (50% lower than previous probes)

**Las sondas flexibles MABS tienen las siguientes características técnicas comunes:**

- Inyector de cerámica distal
- Terminación de la sonda escalada
- Consumo de gas reducido en un 50 % (en comparación con las sondas anteriores)

**Les sondes MABS flexibles présentent les caractéristiques communes suivantes:**

- Buse distale en céramique
- Extrémité de la sonde graduée
- Consommation de gaz réduite de 50 % (par rapport aux anciennes sondes)

**Le sonde flessibili MABS hanno le seguenti caratteristiche comuni:**







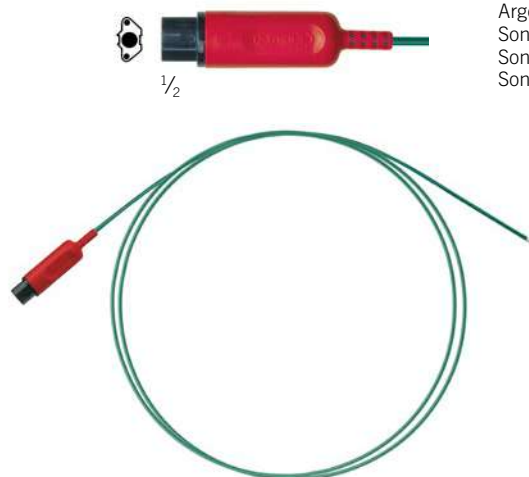

- Ugello distale di ceramica
- Estremità della sonda graduata
- Consumo di gas ridotto del 50 % (nei confronti delle sonde avute sinora)



Argon-Sonde (wiederverwendbar)  
 Argon probe (reusable)  
 Sonda Argon (reutilizable)  
 Sonde Argon (réutilisable)  
 Sonda Argon (riutilizzabile)



Argon-Sonde (Einweg), nicht autoklavierbar  
 Argon probe (disposable), not autoclavable  
 Sonda Argon (desechable), no esterilizable en autoclave  
 Sonde Argon (à usage unique), non autoclavable  
 Sonda Argon (monouso), non autoclavabile

<b>80-181-23-04 max. 4000 V<sub>p</sub></b>					
MABS-GIT-Sonde	Ø 2,3 mm, Länge 2,3 m	wiederverwendbar	(VE 1 Stk.)		
MABS GIT Probe	Ø 2.3 mm, Length 2.3 m	reusable	(1/pack)		
Sonda MABS GIT	Ø 2,3 mm, Largo 2,3 m	reutilizable	(1/unidad)		
Sonde MABS GIT	Ø 2,3 mm, Longueur 2,3 m	réutilisable	(1/unité)		
Sonda MABS GIT	Ø 2,3 mm, Lunghezza 2,3 m	riutilizzabile	(1/unità)		
<b>80-181-24-04 max. 4000 V<sub>p</sub></b>					
MABS-GIT-Sonde	Ø 3,2 mm, Länge 2,3 m	wiederverwendbar	(VE 1 Stk.)		
MABS GIT Probe	Ø 3.2 mm, Length 2.3 m	reusable	(1/pack)		
Sonda MABS GIT	Ø 3,2 mm, Largo 2,3 m	reutilizable	(1/unidad)		
Sonde MABS GIT	Ø 3,2 mm, Longueur 2,3 m	réutilisable	(1/unité)		
Sonda MABS GIT	Ø 3,2 mm, Lunghezza 2,3 m	riutilizzabile	(1/unità)		
<b>80-181-25-04 max. 4000 V<sub>p</sub></b>					
MABS-TBS-Sonde	Ø 1,8 mm, Länge 1,6 m	Einweg	(VE 10 Stk.)		
MABS TBS Probe	Ø 1.8 mm, Length 1.6 m	disposable	(10/pack)		
Sonda MABS TBS	Ø 1,8 mm, Largo 1,6 m	desechable	(10/unidad)		
Sonde MABS TBS	Ø 1,8 mm, Longueur 1,6 m	à usage unique	(10/unité)		
Sonda MABS TBS	Ø 1,8 mm, Lunghezza 1,6 m	monouso	(10/unità)		
<b>80-181-26-04 max. 4000 V</b>					 Double balloon enteroscopy
MABS-GIT-Sonde	Ø 1,8 mm, Länge 3,2 m	Einweg	(VE 10 Stk.)		
MABS GIT Probe	Ø 1.8 mm, Length 3.2 m	disposable	(10/pack)		
Sonda MABS GIT	Ø 1,8 mm, Largo 3,2 m	desechable	(10/unidad)		
Sonde MABS GIT	Ø 1,8 mm, Longueur 3,2 m	usage unique	(10/unité)		
Sonda MABS GIT	Ø 1,8 mm, Lunghezza 3,2 m	monouso	(10/unità)		
<b>80-181-27-04 max. 4300 V<sub>p</sub></b>					
MABS-GIT-Sonde	Ø 2,3 mm, Länge 2,3 m	Einweg	(VE 10 Stk.)		
MABS GIT Probe	Ø 2.3 mm, Length 2.3 m	disposable	(10/pack)		
Sonda MABS GIT	Ø 2,3 mm, Largo 2,3 m	desechable	(10/unidad)		
Sonde MABS GIT	Ø 2,3 mm, Longueur 2,3 m	usage unique	(10/unité)		
Sonda MABS GIT	Ø 2,3 mm, Lunghezza 2,3 m	monouso	(10/unità)		
<b>80-181-28-04 max. 4300 V<sub>p</sub></b>					
MABS-GIT-Sonde	Ø 3,2 mm, Länge 2,3 m	Einweg	(VE 10 Stk.)		
MABS GIT Probe	Ø 3.2 mm, Length 2.3 m	disposable	(10/pack)		
Sonda MABS GIT	Ø 3,2 mm, Largo 2,3 m	desechable	(10/unidad)		
Sonde MABS GIT	Ø 3,2 mm, Longueur 2,3 m	usage unique	(10/unité)		
Sonda MABS GIT	Ø 3,2 mm, Lunghezza 2,3 m	monouso	(10/unità)		
<b>80-181-29-04 max. 4300 V<sub>p</sub></b>					 Double balloon enteroscopy
MABS-GIT-Sonde	Ø 2,3 mm, Länge 3,4 m	Einweg	(VE 10 Stk.)		
MABS GIT Probe	Ø 2.3 mm, Length 3.4 m	disposable	(10/pack)		
Sonda MABS GIT	Ø 2,3 mm, Largo 3,4 m	desechable	(10/unidad)		
Sonde MABS GIT	Ø 2,3 mm, Longueur 3,4 m	usage unique	(10/unité)		
Sonda MABS GIT	Ø 2,3 mm, Lunghezza 3,4 m	monouso	(10/unità)		
<b>80-181-32-04 max. 4300 V<sub>p</sub></b>					 Side Fire
MABS-GIT-Sonde	Ø 2,3 mm, Länge 2,3 m	Einweg	(VE 10 Stk.)		
MABS GIT Probe	Ø 2.3 mm, Length 2.3 m	disposable	(10/pack)		
Sonda MABS GIT	Ø 2,3 mm, Largo 2,3 m	desechable	(10/unidad)		
Sonde MABS GIT	Ø 2,3 mm, Longueur 2,3 m	usage unique	(10/unité)		
Sonda MABS GIT	Ø 2,3 mm, Lunghezza 2,3 m	monouso	(10/unità)		

Weitere Informationen entnehmen Sie bitte der separaten Broschüre.

For further information please refer to our separate product brochure.

Encontrará informaciones adicionales en el folleto individual.

Vous trouverez des informations supplémentaires dans la brochure.

Per ulteriori informazioni vedasi il prospetto separato.



MABS-Snare-Sonden „aus ZWEI mach EINS“  
MABS Snare probes – “TWO in ONE”  
Sondas MABS Snare – “DOS en UNA”  
Sondes MABS Snare – «DEUX en UNE»  
Sonde MABS Snare – “DUE in UNA”

Argon-Beamer-System  
Argon Beamer System  
Sistema Argon Beamer  
Système Argon Beamer  
Sistema Argon Beamer



**80-181-41-04 max. 4300 V<sub>p</sub>**

MABS-GIT-Snare-Sonde	Ø 2,5 mm, Länge 2,3 m	15 mm, multifil.,	Einweg	(VE 5 Stk.)
MABS GIT Snare Probe	Ø 2.5 mm, Length 2.3 m	15 mm, multifil.,	disposable	(5/pack)
Sonda GIT TBS Snare	Ø 2,5 mm, Largo 2,3 m	15 mm, multifil.,	desechable	(5/unidad)
Sonde GIT TBS Snare	Ø 2,5 mm, Longueur 2,3 m	15 mm, multifil.,	à usage unique	(5/unité)
Sonda GIT TBS Snare	Ø 2,5 mm, Lunghezza 2,3 m	15 mm, multifil.,	monouso	(5/unità)



Snare multifil

**80-181-42-04 max. 4300 V<sub>p</sub>**

MABS-GIT-Snare-Sonde	Ø 2,5 mm, Länge 2,3 m	30 mm, multifil.,	Einweg	(VE 5 Stk.)
MABS GIT Snare Probe	Ø 2.5 mm, Length 2.3 m	30 mm, multifil.,	disposable	(5/pack)
Sonda GIT TBS Snare	Ø 2,5 mm, Largo 2,3 m	30 mm, multifil.,	desechable	(5/unidad)
Sonde GIT TBS Snare	Ø 2,5 mm, Longueur 2,3 m	30 mm, multifil.,	à usage unique	(5/unité)
Sonda GIT TBS Snare	Ø 2,5 mm, Lunghezza 2,3 m	30 mm, multifil.,	monouso	(5/unità)



beam

**80-181-43-04 max. 4300 V<sub>p</sub>**

MABS-GIT-Snare-Sonde	Ø 2,5 mm, Länge 2,3 m	15 mm, monofil.,	Einweg	(VE 5 Stk.)
MABS GIT Snare Probe	Ø 2.5 mm, Length 2.3 m	15 mm, monofil.,	disposable	(5/pack)
Sonda GIT TBS Snare	Ø 2,5 mm, Largo 2,3 m	15 mm, monofil.,	desechable	(5/unidad)
Sonde GIT TBS Snare	Ø 2,5 mm, Longueur 2,3 m	15 mm, monofil.,	à usage unique	(5/unité)
Sonda GIT TBS Snare	Ø 2,5 mm, Lunghezza 2,3 m	15 mm, monofil.,	monouso	(5/unità)



Snare monofil

**80-181-44-04 max. 4300 V<sub>p</sub>**

MABS-GIT-Snare-Sonde	Ø 2,5 mm, Länge 2,3 m	30 mm, monofil.,	Einweg	(VE 5 Stk.)
MABS GIT Snare Probe	Ø 2.5 mm, Length 2.3 m	30 mm, monofil.,	disposable	(5/pack)
Sonda GIT TBS Snare	Ø 2,5 mm, Largo 2,3 m	30 mm, monofil.,	desechable	(5/unidad)
Sonde GIT TBS Snare	Ø 2,5 mm, Longueur 2,3 m	30 mm, monofil.,	à usage unique	(5/unité)
Sonda GIT TBS Snare	Ø 2,5 mm, Lunghezza 2,3 m	30 mm, monofil.,	monouso	(5/unità)



beam

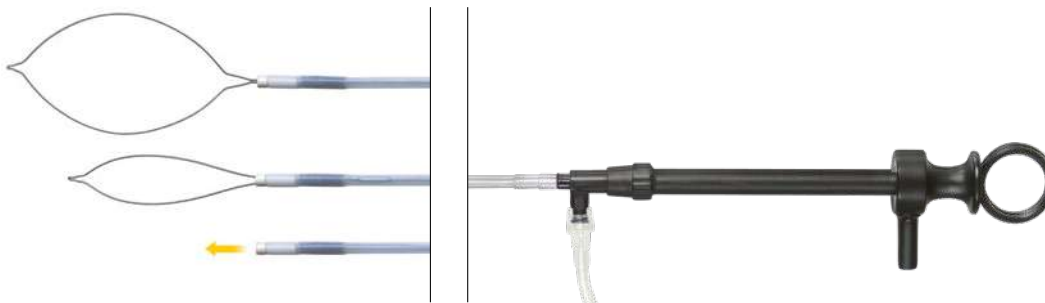

Die MABS-Snare-Sonden sind Kombinationssonden, die für die Abtragung von Polypen und eine anschließende Koagulation mittels Argonbeam verwendet werden können.

MABS Snare probes are combination probes allowing you to remove polyps with subsequent argon coagulation of the site.

Las sondas MABS Snare son sondas combinadas, que pueden utilizarse para la remoción de pólipos y una coagulación posterior mediante plasma de gas argón.

Les sondes MABS Snare sont des sondes combinées qui peuvent être utilisées pour l'ablation de polypes suivie d'une coagulation moyennant un faisceau d'argon.

Le sonde MABS Snare sono sonde combinate che consentono la rimozione di polipi con successiva coagulazione ad argon del sito.

Weitere Informationen entnehmen Sie bitte der separaten Broschüre.

For further information please refer to our separate product brochure.

Encontrará informaciones adicionales en el folleto individual.

Vous trouverez des informations supplémentaires dans la brochure.

Per ulteriori informazioni vedasi il prospetto separato.



**80-289-40-04 max. 4000 V<sub>p</sub>**

4 m  
Monopolares Anschlusskabel für KLS-Martin-HF-Geräte  
Monopolar connecting cable for KLS Martin HF units  
Cable de conexión monopolar para equipos de AF de KLS Martin  
Câble de raccordement monopolaire pour appareils HF KLS Martin  
Cavo di collegamento monopolare per apparecchi AF di KLS Martin



**80-289-41-04 max. 4000 V<sub>p</sub>**

4 m  
Monopolares Anschlusskabel für HF-Geräte mit 3-Pin-Stecker  
Monopolar connecting cable for HF units with 3-pin plugs  
Cable de conexión monopolar para equipos de AF con clavija de 3 patillas  
Câble de raccordement monopolaire pour appareils HF avec fiche à 3 broches  
Cavo di collegamento monopolare per apparecchi AF con spina a 3-spire

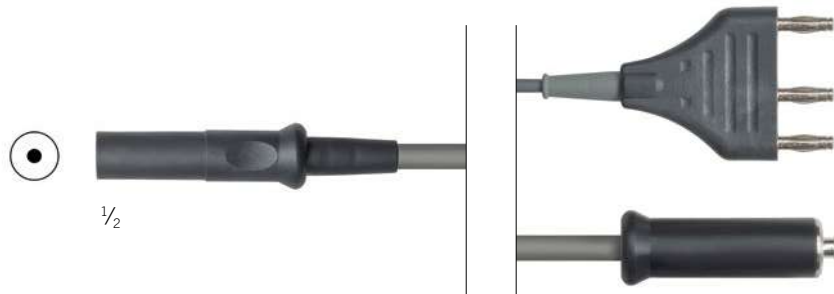

80-181-17-04 **max. 4300 V<sub>p</sub>**

MABS-Anschlussleitung für Erbe-Sonden, mit Rundstecker  
 MABS connection cable for Erbe probes, with circular connector  
 Cable de conexión MABS para sondas Erbe, con clavija redonda  
 Câble de connexion MABS pour sondes Erbe, avec connecteur rond  
 Cavo di collegamento MABS per sonda Erbe, con spina tonda



80-181-90-04

MABS-Sterilfilter, VE = 50 Stück  
 MABS sterile filter, SU = 50/pack  
 Filtro estéril MABS, UV = 50 piezas  
 Filtre stérile MABS, UC = 50 unités  
 Filtro sterile MABS, UV = 50 pezzi



**maXium®**

**maXium®** Beamer

**maXium®** smart Vac

**maXium®** smart Cart

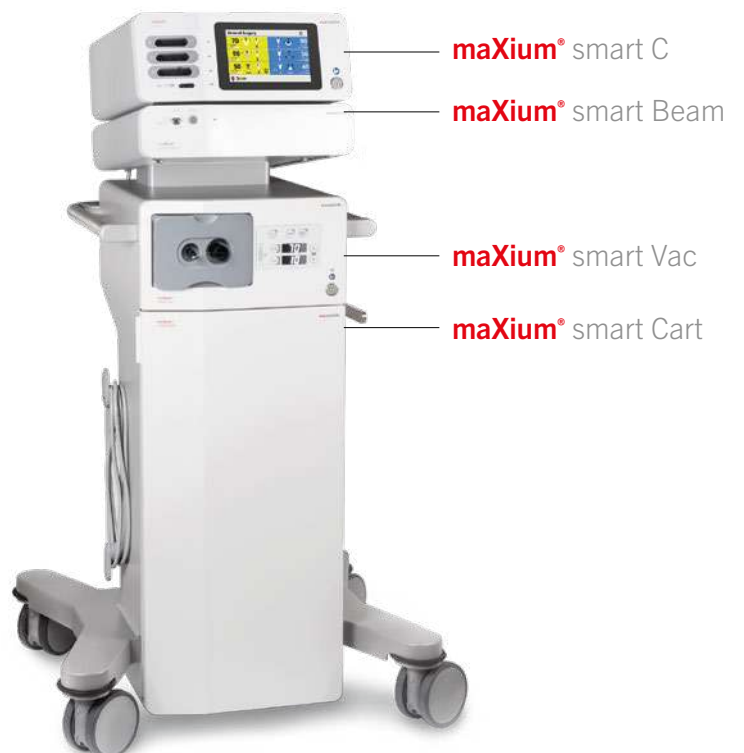

**maXium®** smart C

**maXium®** smart Beam

**maXium®** smart Vac

**maXium®** smart Cart



	<b>Norm Standard Norma Norma Norma</b>	<b>Länder Countries Países Pays Paesi</b>
80-181-52-04	DIN 477, Nr. 6	D, A, CH, P, E, GR
80-181-53-04	DIN 477, Nr. 10	NL, DK, S, NOR, B
80-181-54-04	UNI 4412	I
80-181-55-04	BS 341, Nr. 3	UK, AUS, MY, IN, TR, former Commonwealth
80-181-56-04	CGA, Nr. 580	USA, MX, TH, South America
80-181-57-04		China
80-181-58-04	ISO 5145, Nr. 4	F

MABS-Druckminderer mit Schlauch und Schnellkupplung 2,5 bis 4,5 bar, Schlauchlänge 1,2 m  
MABS pressure reducer with flexible tube and quick-action coupling 2.5 to 4.5 bar, tube length: 1.2 m  
Manorreductor MABS con tubo y acoplamiento rápido 2,5 a 4,5 bar, longitud del tubo: 1,2 m  
Décompresseur MABS avec tuyau et raccord pompier 2,5 à 4,5 bar, longueur de tuyau 1,2 m  
Riduttore di pressione MABS con tubo flessibile e attacco rapido da 2,5 a 4,5 bar, lunghezza tubo 1,2 m

**MABS-Anschluss an zentrale Argon-Versorgung**  
**MABS connection to central argon supply**  
**Conexión MABS al suministro central de argón**  
**Raccord MABS à l'alimentation centrale en gaz argon**  
**Attacco MABS all'alimentazione centrale di argon**

92-800-74-04

MABS-Verbindungsschlauch, mit Vierkant  
MABS connection tubing, with square  
Tubo de conexión MABS, conector cuadrado  
Tubulure de connexion MABS, avec carré  
Tubo di connessione MABS, con raccordo quadrato

94-179-58-04

Gasflasche mit Füllung Argongas 4.8, 5 ltr.  
Gas bottle with "4.8 quality" argon gas filling, 5 ltr.  
Bombona de gas con relleno de gas argón 4.8, 5 ltr.  
Bouteille de gaz avec remplissage de gaz d'argon 4.8, 5 ltr.  
Bombola di gas con riempimento di gas argon 4.8, 5 ltr.



94-179-59-04

Argon-Gasflasche, ohne Füllung, 5 ltr., Anschluß DIN 477, Nr. 6  
Argon gas cylinder, empty, 5 ltr., connection DIN 477, No. 6  
Bombona de gas argón, vacía, 5 ltr., conexión DIN 477, n.º 6  
Bouteille de gaz d'argon, vide, 5 ltr., raccord DIN 477, n° 6  
Bombola di gas argon, vuota, 5 ltr., attacco DIN 477, n. 6

oder über den örtlichen Lieferanten erhältlich  
or available through your local supplier  
o pueden obtenerse a través del proveedor local  
ou disponibles auprès des fournisseurs locaux  
o disponibili presso il fornitore locale

Bitte besondere Versandvorschriften beachten!  
Please note special shipping regulations!  
¡Rogamos tengan en cuenta las disposiciones especiales de envío!  
Expédition soumise à des dispositions réglementaires particulières!  
Si prega di osservare le particolari prescrizioni per la spedizione!

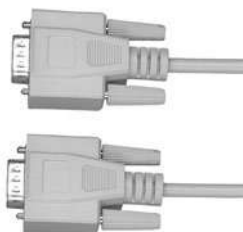

**ME 411  
ME CD1**

80-181-50-04

1 m  
MABS-Schnittstellenkabel  
MABS interface cable  
Cable de interfaz MABS  
Câble interface MABS  
Cavo interfaccia MABS



80-181-51-04

MABS-Verbindungskabel  
MABS connecting cable  
Cable de conexión MABS  
Câble de connexion MABS  
Cavo di collegamento MABS

**ME MB 3/ME MB 2/ME MB 1**

Fremdgeräte mit dieser  
Steckerverbindung

Third-party devices with this type  
of connector

Aparatos de otros fabricantes con  
esta conexión de enchufe

Appareils externes avec cette  
connexion des prises

Apparecchi di altri produttori con  
questa connessione della spina

Übersicht der MABS-Grundausrüstung  
 Overview of MABS basic equipment  
 Vista general del equipo básico del MABS  
 Vue d'ensemble de l'équipement de base MABS  
 Schema della dotazione di base MABS

	Technisches Zubehör	Technical accessories	Accesorios técnicos
	<b>Kombination</b>	<b>Combination</b>	<b>Combinación</b>
80-048-00-04	maXium® smart Cart	maXium® smart Cart	maXium® smart Cart
80-048-04-04	Geräteaufnahme maXium® auf maXium® smart Cart	Support maXium® to maXium® smart Cart	Alojamiento aparato maXium® en maXium® smart Cart
80-048-05-04	Gasflaschenhalter für maXium® smart Cart	Support for argon gas cylinder	Sop. para cilindro de gas para maXium® smart Cart
80-044-00-04	maXium® Beamer	maXium® Beamer	maXium® Beamer
	zu wählen	to be selected	a seleccionar
80-042-00-04	maXium® <b>m</b>	maXium® <b>m</b>	maXium® <b>m</b>
80-042-02-04	maXium® <b>i</b>	maXium® <b>i</b>	maXium® <b>i</b>
80-042-04-04	maXium® <b>e</b>	maXium® <b>e</b>	maXium® <b>e</b>

	Kombination	Combination	Combinación
80-048-00-04	maXium® smart Cart	maXium® smart Cart	maXium smart Cart
80-048-03-04	Geräteaufnahme smartLine auf maXium® smart Cart	Support smartLine to maXium® smart Cart	Alojamiento aparato smartLine en maXium® smart Cart
80-048-05-04	Gasflaschenhalter für maXium® smart Cart	Support for argon gas cylinder	Sop. para cilindro de gas para maXium® smart Cart
80-043-10-04	maXium® smart Beam	maXium® smart Beam	maXium® smart Beam
	zu wählen	to be selected	a seleccionar
80-043-00-04	maXium® smart C <b>m</b>	maXium® smart C <b>m</b>	maXium® smart C <b>m</b>
80-043-01-04	maXium® smart C <b>i</b>	maXium® smart C <b>i</b>	maXium® smart C <b>i</b>
80-043-02-04	maXium® smart C <b>e</b>	maXium® smart C <b>e</b>	maXium® smart C <b>e</b>

	Druckmindererauswahl (nach Länderstandard)	Selection of pressure reducers (acc. to national standards)	Selección de manorreductores (según los estándares de países)
80-181-52-04	MABS-Druckminderer, DIN 477 Nr. 6, für D, A, CH, P, E, GR	MABS pressure reducer, DIN 477 No. 6, for D, A, CH, P, E, GR	Manorreductor MABS, DIN 477 N°. 6, para D, A, CH, P, E, GR
80-181-53-04	MABS-Druckminderer, DIN 477 Nr. 10, für NL, DK, S, NOR, B	MABS pressure reducer, DIN 477 No. 10, for NL, DK, S, NOR, B	Manorreductor MABS, DIN 477 N°. 10, para NL, DK, S, NOR, B
80-181-54-04	MABS-Druckminderer, UNI 4412, für I	MABS pressure reducer, UNI 4412, for I	Manorreductor MABS, UNI 4412, para I
80-181-55-04	MABS-Druckminderer, BS 341 Nr. 3, für GB, AUS, Malaysia, Indien, ehem. Commonwealth, Türkei	MABS pressure reducer, BS 341 No. 3, for GB, AUS, Malaysia, India, former Commonwealth, Turkey	Manorreductor MABS, BS 341 N°. 3, para GB, AUS, Malasia, India, ex-Comunidad Británica de Naciones, Turquía
80-181-56-04	MABS-Druckminderer. CGA Nr. 580. für USA, Südamerika, Mexiko, Thailand	MABS pressure reducer. CGA No. 580. for USA, South America, Mexico, Thailand	Manorreductor MABS. CGA Nr. 580. para EE.UU., Sudamérica, México, Tailandia
80-181-57-04	MABS-Druckminderer, China	MABS pressure reducer, China	Manorreductor MABS, China
80-181-58-04	ISO 5145 Nr. 4, F	ISO 5145 No. 4, F	ISO 5145 N° 4, F

	Klinisches Zubehör (starr) für die offene Chirurgie (Ø 5 mm)	Clinical accessories (rigid) for open surgery (Ø 5 mm)	Accesorios clínicos (rígidos) para la cirugía abierta (Ø 5 mm)
80-181-02-04	MABS-Handgriff, für starre Elektroden	MABS handle, for rigid electrodes	Interruptor de mango MABS, para electrodos rígidos
80-181-10-04	MABS-Beam-Elektrode, Arbeitslänge 25 mm	MABS beam electrode, working length 25 mm	Electrodo MABS Beam, longitud de trabajo: 25 mm
80-181-11-04	MABS-Beam-Elektrode, Arbeitslänge 100 mm	MABS beam electrode, working length 100 mm	Electrodo MABS Beam, longitud de trabajo: 100 mm
80-181-13-04	MABS-Lanzetten-Elektrode, Arbeitslänge 25 mm	MABS lancet electrode, working length 25 mm	Electrodo MABS de lanceta, longitud de trabajo: 25 mm
80-181-14-04	MABS-Lanzetten-Elektrode, Arbeitslänge 115 mm	MABS lancet electrode, working length 115 mm	Electrodo MABS de lanceta, longitud de trabajo: 115 mm
80-181-15-04	MABS-Nadel-Elektrode, Arbeitslänge 40 mm	MABS needle electrode, working length 40 mm	Electrodo MABS de aguja, longitud de trabajo: 40 mm
80-181-16-04	MABS-Nadel-Elektrode, Arbeitslänge 115 mm	MABS needle electrode, working length 115 mm	Electrodo MABS de aguja, longitud de trabajo: 115 mm

	Klinisches Zubehör (starr) für die laparoskopische Chirurgie (Ø 5 mm)	Clinical accessories (rigid) for laparoscopic surgery	Accesorios clínicos (rígidos) para la cirugía laparoscópica
80-181-02-04	MABS-Handgriff, für starre Elektroden	MABS handle, for rigid electrodes	Interruptor de mango MABS, para electrodos rígidos
80-181-12-04	MABS-Beam-Elektrode, Arbeitslänge 320 mm	MABS beam electrode, working length 320 mm	Electrodo MABS Beam, longitud de trabajo: 320 mm

	Klinisches Zubehör (flexibel) für die endoskopische Chirurgie	Clinical accessories (flexible) for endoscopic surgery	Accesorios clínicos (flexibles) para la cirugía endoscópica
80-181-30-04	MABS-Anschlussleitung	MABS connection cable	Cable de conexión MABS
80-181-25-04	MABS-TBS-Sonde, flexibel, Einweg (Ø 1,8 mm/Länge 1,6 m)	MABS TBS probe, flexible, disposable, Ø 1.8 mm, working length 1.6 m	Sonda MABS TBS, flexible, desechable, Ø 1,8 mm/ longitud de trabajo: 1,6 m
80-181-23-04	MABS-GIT-Sonde, flexibel, wiederverwendbar (Ø 2,3 mm/Länge 2,3 m)	MABS GIT probe, flexible, reusable, Ø 2.3 mm, working length 2.3 m	Sonda MABS GIT, flexible, reutilizable, Ø 2,3 mm/ longitud de trabajo: 2,3 m
80-181-24-04	MABS-GIT-Sonde, flexibel, wiederverwendbar (Ø 3,2 mm/Länge 2,3 m)	MABS GIT probe, flexible, reusable, Ø 3.2 mm, working length 2.3 m	Sonda MABS GIT, flexible, reutilizable, Ø 3,2 mm/ longitud de trabajo: 2,3 m
	alternativ: Einwegsonden, flexibel, siehe Seite 138	alternatively: Disposable probes, flexible, see page 138	alternativa: Sondas desechables, flexibles, véase página 138

	Optional	Optional	Accesorios opcionales
80-181-51-04	MABS-Fußschaltersignalkabel	MABS foot switch signal cable	Cable de señalización para el interruptor de pedal MABS
80-830-00-04	Doppelpedal-Fußschalter (monopolar), schwere Ausführung	Double-pedal foot switch (monopolar), heavy-duty design	Interruptor de pie de doble pedal (monopolar), modelo pesado
80-811-30-04	Doppelpedal-Fußschalter (monopolar), leichte Ausführung	Double-pedal foot switch (monopolar), light-duty design	Interruptor de pie de doble pedal (monopolar), modelo ligero
80-294-40-04	Anschlusskabel für Einmal-Neutralelektroden*	Connection cable for disposable neutral electrodes*	Cable de conexión para electrodos neutros de uso único*
80-294-44-04			
80-181-90-04	Sterilfilter, VE = 50 Stck.	Sterile filter, SU = 50/pack	Filtro estéril, UV = 50 piezas

\* vom HF-Gerät abhängig

\* depending on HF device

\* en función del aparato de AF

#### Hinweise:

1. Für die Gewährleistung eines kontinuierlichen OP-Ablaus sind die klinikinternen Aufbereitungszyklen zu berücksichtigen. Das Zubehör ist vor diesem Hintergrund entsprechend zu quantifizieren.

2. Argongas 4.8 in handelsüblicher Flaschenform (5 l oder 10 l) ist bei den örtlichen Lieferanten erhältlich.

#### Notes:

1. Smooth OR processes require the seamless integration of the hospital's instrument processing cycles and, consequently, the availability of a sufficient quantity of accessories.

2. "4.8 quality" argon gas may be obtained from local suppliers (to be delivered in commonly used 5-l or 10-l cylinders).

#### Indicaciones:

1. Para garantizar el desarrollo continuado de las secuencias en el quirófano, deberán tenerse en cuenta los ciclos de procesamiento internos de la clínica. Las cantidades de accesorios deberán planificarse en consecuencia.

2. El gas argón 4.8 se obtiene de los proveedores locales en las bombonas de gas usuales (de 5 ó 10 litros).





	<b>Accessoires cliniques (rigides) pour la chirurgie laparoscopique</b>	<b>Accessori clinici (rigidi) per la chirurgia laparoscopica</b>
80-181-02-04	Poignée MABS, pour électrodes rigides	Impugnatura MABS, per elettrodi rigidi
80-181-12-04	Électrode du diffuseur MABS, longueur de travail 320 mm	Elettrodo MABS Beam, lunghezza di lavoro 320 mm

	<b>Accessoires cliniques (flexibles) pour la chirurgie endoscopique</b>	<b>Accessori clinici (flessibili) per la chirurgia endoscopica</b>
80-181-30-04	Conduite de raccord MABS	Cavo di collegamento MABS
80-181-25-04	Sonde MABS TBS, flexible, à usage unique , Ø 1,8 mm/longueur de travail 1,6 m	Sonda MABS TBS, flessibile, monouso Ø 1,8 mm/lunghezza di lavoro 1,6 m
80-181-23-04	Sonde MABS GIT, flexible, réutilisable Ø 2,3 mm/longueur de travail 2,3 m	Sonda MABS GIT, flessibile, riutilizzabile Ø 2,3 mm/lunghezza di lavoro 2,3 m
80-181-24-04	Sonde MABS GIT, flexible, réutilisable Ø 3,2 mm/longueur de travail 2,3 m	Sonda MABS GIT, flessibile, riutilizzabile Ø 3,2 mm/lunghezza di lavoro 2,3 m
	ou bien: Sondes à usage unique, flexibles, voir page 138	come alternativa: Sonde monouso, flessibili, vedi pagina 138

	<b>En option</b>	<b>Opzioni</b>
80-181-51-04	Câble signal pour interrupteur à ped MABS	Cavo di segnale per l'interruttore a pedale MABS
80-821-02-04	Interrupteur à pédale double (monopolaire), modèle lourd	Interruttore a pedale doppio (monopolare), esecuzione pesante
80-811-30-04	Interrupteur à pédale double (monopolaire), modèle léger	Interruttore a pedale doppio(monopolare), esecuzione leggera
80-294-40-04	Câble raccord pour des électrodes neutres à usage unique*	Cavo di collegamento per elettrodi neutri monouso*
80-181-90-04	Filtre stérile, UC = 50 pièces	Filtro sterile, UV = 50 pezzi

\*dépend du dispositif HF

\*a seconda dell'unità AF

#### Indications:

1. Il convient de tenir compte des cycles de traitement cliniques internes pour assurer la continuité des processus en salle d'opération. Par conséquent, il faudra veiller à toujours disposer d'accessoires en nombre suffisant.

2. Le gaz d'argon 4.8 est disponible dans des bouteilles à gaz usuelles dans le commerce (5 l ou 10 l) auprès des fournisseurs locaux.

#### Avvertenze

1. Per garantire un intervento operatorio continuato, devono essere considerati i cicli di preparazione interni. Gli accessori devono essere quantificati in base a queste esigenze.

2. Il gas argon 4.8 in bombole comuni (da 5 o 10 litri) può essere acquistato presso i fornitori locali.

Rauchgasabsaugung und Zubehör  
Smoke evacuator and accessories  
Evacuación de gases de combustión y accesorios  
Évacuateur de fumée et accessoires  
Aspiratore di fumo e accessori

# 8





- |               |           |            |             |            |
|---------------|-----------|------------|-------------|------------|
| ✓ Effektiv    | Effective | Efectivo   | Performant  | Effettivo  |
| ✓ Ergonomisch | Ergonomic | Ergonómico | Ergonomique | Ergonomico |
| ✓ Sicher      | Safe      | Seguro     | Sûr         | Sicuro     |

	marVac® Produktbeschreibung	marVac® Product Description	marVac® Descripción de producto
80-060-00-04	Rauchgasabsaugung marVac® 220–240 V inkl. Hauptfilter (Art.-Nr. 80-060-01-04) und Verbindungssatz für HF-Grossgeräte	marVac® smoke evacuator, 220–240 V, incl. main filter (item no. 80-060-01-04) and connection kit for major electrosurgery units	Evacuación de gases de combustión marVac®, 220 – 240 V, incl. filtro principal (n.º ref. 80-060-01-04) y juego de conexión para gran aparatos
80-060-00-10	Rauchgasabsaugung marVac® 100 V   110 V   120 V   127 V, inkl. Hauptfilter (Art.-Nr. 80-060-01-04) und Verbindungssatz für HF-Grossgeräte	marVac® smoke evacuator, 100 V   110 V   120 V   127 V, incl. main filter (item no. 80-060-01-04) and connection kit for major electrosurgery units	Evacuación de gases de combustión marVac®, 100 V   110 V   120 V   127 V, incl. filtro principal (n.º ref. 80-060-01-04) y juego de conexión para gran aparatos
80-061-00-04	Rauchgasabsaugung marVac® mit <b>LAP-Modus</b> , 220-240 V inkl. Hauptfilter (Art.-Nr. 80-060-01-04) und Verbindungssatz für HF-Grossgeräte	marVac® smoke evacuator with <b>LAP mode</b> , 220–240 V, incl. main filter (item no. 80-060-01-04) and connection kit for major electrosurgery units	Evacuación de gases de combustión marVac® con <b>modo LAP</b> , 220 – 240 V, incl. filtro principal (n.º ref. 80-060-01-04) y juego de conexión para gran aparatos
80-061-00-10	Rauchgasabsaugung marVac® mit <b>LAP-Modus</b> , 100 V   110 V   120 V   127 V, inkl. Hauptfilter (Art.-Nr. 80-060-01-04) und Verbindungssatz für HF-Grossgeräte	marVac® smoke evacuator with <b>LAP mode</b> , 100 V   110 V   120 V   127 V, incl. main filter (item no. 80-060-01-04) and connection kit for major electrosurgery units	Evacuación de gases de combustión marVac® con <b>modo LAP</b> , 100 V   110 V   120 V   127 V, incl. filtro principal (n.º ref. 80-060-01-04) y juego de conexión para gran aparatos



8

	<b>marVac®</b> <b>Description du produit</b>	<b>marVac®</b> <b>Descrizione del prodotto</b>
80-060-00-04	Evacuateur de fumée marVac®, 220 – 240 V, y compris filtre principal (réf. 80-060-01-04) et set de connexion pour grands appareils	Aspiratore di fumo marVac®, 220 – 240 V, incl. filtro principale (codice art. 80-060-01-04) e set di collegamento per apparecchi grandi
80-060-00-10	Evacuateur de fumée marVac®, 100 V   110 V   120 V   127 V y compris filtre principal (réf. 80-060-01-04) et set de connexion pour grands appareils	Aspiratore di fumo marVac®, 100 V   110 V   120 V   127 V incl. filtro principale (codice art. 80-060-01-04) e set di collegamento per apparecchi grandi
80-061-00-04	Evacuateur de fumée marVac® avec <b>mode LAP</b> , 220 – 240 V, y compris filtre principal (réf. 80-060-01-04) et set de connexion pour grands appareils	Aspiratore di fumo marVac®, 220 – 240 V, con <b>modalità LAP</b> , incl. filtro principale (codice art. 80-060-01-04) e set di collegamento per apparecchi grandi
80-061-00-10	Evacuateur de fumée marVac® avec <b>mode LAP</b> , 100 V   110 V   120 V   127 V, y compris filtre principal (réf. 80-060-01-04) et set de connexion pour grands appareils	Aspiratore di fumo marVac®, 100 V   110 V   120 V   127 V, con <b>modalità LAP</b> , incl. filtro principale (codice art. 80-060-01-04) e set di collegamento per apparecchi grandi

Weitere Informationen entnehmen Sie bitte der separaten Broschüre.

For further information please refer to our separate product brochure.

Encontrará informaciones adicionales en el folleto individual.

Vous trouverez des informations supplémentaires dans la brochure.

Per ulteriori informazioni vedasi il prospetto separato.





- |               |           |            |             |            |
|---------------|-----------|------------|-------------|------------|
| ✓ Effektiv    | Effective | Efectivo   | Performant  | Effettivo  |
| ✓ Ergonomisch | Ergonomic | Ergonómico | Ergonomique | Ergonomico |
| ✓ Sicher      | Safe      | Seguro     | Sûr         | Sicuro     |

	Für den Einbau in das maXium® smart Cart	Für den Einbau in das maXium® smart Cart	Für den Einbau in das maXium® smart Cart
	<b>maXium® smart Vac</b> Produktbeschreibung	<b>maXium® smart Vac</b> Product description	<b>maXium® smart Vac</b> Descripción de producto
80-062-00-04	Rauchgasabsaugung maXium® smart Vac mit <b>LAP-Modus</b> , 220–240 V inkl. Hauptfilter (Art.-Nr. 80-060-01-04)	Smoke evacuation system maXium® smart Vac with <b>LAP-Mode</b> , 220–240 V incl. main filter unit (item 80-060-01-04)	Evacuación de gases de combustión maXium® smart Vac con <b>modo LAP</b> , 220–240 V incl. filtro principal (no. ref. 80-060-01-04)
80-062-00-10	Rauchgasabsaugung maXium® smart Vac mit <b>LAP-Modus</b> , 100 V   110 V   120 V   127 V, inkl. Hauptfilter (Art.-Nr. 80-060-01-04)	Smoke evacuation system maXium® smart Vac with <b>LAP-Mode</b> , 100 V   110 V   120 V   127 V, incl. main filter unit (item 80-060-01-04)	Evacuación de gases de combustión maXium® smart Vac con <b>modo LAP</b> , 100 V   110 V   120 V   127 V, incl. filtro principal (no. ref. 80-060-01-04)
80-062-01-04	Rauchgasabsaugung maXium® smart Vac, 220–240 V inkl. Hauptfilter (Art.-Nr. 80-060-01-04)	Smoke evacuation system maXium® smart Vac, 220–240 V incl. main filter unit (item 80-060-01-04)	Evacuación de gases de combustión maXium® smart Vac, 220–240 V, incl. filtro principal (no. ref. 80-060-01-04)
80-062-01-10	Rauchgasabsaugung maXium® smart Vac, 100–127 V inkl. Hauptfilter (Art.-Nr. 80-060-01-04) 100 V   110 V   120 V   127 V	Smoke evacuation system maXium® smart Vac, 100–127 V incl. main filter unit (item 80-060-01-04) 100 V   110 V   120 V   127 V	Evacuación de gases de combustión maXium® smart Vac, 100–127 V, incl. filtro principal (no. ref. 80-060-01-04) 100 V   110 V   120 V   127 V
80-048-06-04	Befestigungssatz für maXium® smart Vac®	Mounting kit for maXium® smart Vac®	Kit de fijación para maXium® smart Vac®
	<b>Optionale Komponenten:</b> zu bestellen bei Verwendung der maXium® smart Vac als Stand-Alone-Variante:	<b>Optional components:</b> for ordering when using the maXium® smart Vac as stand-alone version:	<b>Componentes opcionales:</b> se deben encargar si se utiliza maXium® smart Vac como variante independiente:
80-062-05-04	maXium® smart Vac, Gehäusedeckel, Stand-Alone	maXium® smart Vac, housing cover, stand-alone	maXium® smart Vac, tapa, equipo individual
	<b>zu bestellen bei Platzierung der maXium® smart Vac direkt unter dem maXium® smart C (z. B. auf Deckenversorgungsheinheit)</b>	<b>for ordering with placement of the maXium® smart Vac immediately below the maXium® smart C (e.g. on ceiling supply unit)</b>	<b>se debe encargar si se coloca maXium® smart Vac directamente debajo de maXium® smart C (p. ej., en unidad de alimentación de techo)</b>
80-062-06-04	maXium® smart Vac, Gehäusedeckel zur Verbindung mit maXium® smart C	maXium® smart Vac, housing cover for maXium® smart C	maXium® smart Vac, tapa para maXium® smart C



	<b>Für den Einbau in das maXium® smart Cart</b>	<b>Für den Einbau in das maXium® smart Cart</b>
	<b>maXium® smart Vac</b>	<b>maXium® smart Vac</b>
	<b>Description du produit</b>	<b>Descrizione del prodotto</b>
80-062-00-04	Évacuateur de fumée maXium® smart Vac avec <b>mode LAP</b> , 220–240 V y compris filtre principal (réf. 80-060-01-04)	Aspiratore di fumo maXium® smart Vac con <b>modalità LAP</b> , 220–240 V, incl. filtro principale (codice art. 80-060-01-04)
80-062-00-10	Évacuateur de fumée maXium® smart Vac avec <b>mode LAP</b> , 100 V   110 V   120 V   127 V, y compris filtre principal (réf. 80-060-01-04)	Aspiratore di fumo maXium® smart Vac con <b>modalità LAP</b> , 100 V   110 V   120 V   127 V, incl. filtro principale (codice art. 80-060-01-04)
80-062-01-04	Évacuateur de fumée maXium® smart Vac, 220–240 V y compris filtre principal (réf. 80-060-01-04)	Aspiratore di fumo maXium® smart Vac, 220–240 V, incl. filtro principale (codice art. 80-060-01-04)
80-062-01-10	Évacuateur de fumée maXium® smart Vac, 100-127 V y compris filtre principal (réf. 80-060-01-04) 100 V   110 V   120 V   127 V	Aspiratore di fumo maXium® smart Vac, 100-127 V, incl. filtro principale (codice art. 80-060-01-04) 100 V   110 V   120 V   127 V
80-048-06-04	Set de fixation pour maXium® smart Vac®	Set di fissaggio per maXium® smart Vac®
	<b>Composants facultatifs:</b> <b>à commander en cas d'utilisation du maXium® smart Vac à titre de variante autonome :</b>	<b>Componenti opzionali:</b> <b>da ordinare in caso d'impiego del maXium® smart Vac come variante stand-alone:</b>
80-062-05-04	maXium® smart Vac, couvercle, solution autonome	maXium® smart Vac, coperchio, stand-alone
	<b>à commander en cas de positionnement du maXium® smart Vac directement sous le maXium® smart C (par ex. sur une unité d'alimentation au plafond)</b>	<b>da ordinare per il posizionamento del maXium® smart Vac direttamente sotto il maXium® smart C (ad es. su alimentatore a soffitto)</b>
80-062-06-04	maXium® smart Vac, couvercle pour maXium® smart C	maXium® smart Vac, coperchio per maXium® smart C

Weitere Informationen entnehmen Sie bitte der separaten Broschüre.  
For further information please refer to our separate product brochure.  
Encontrará informaciones adicionales en el folleto individual.  
Vous trouverez des informations supplémentaires dans la brochure.  
Per ulteriori informazioni vedasi il prospetto separato.



Zubehör		Accessories	Accesorios
	<b>Individuelle Zubehöerteile</b>	<b>Optional accessories</b>	<b>Accesorios opcionales</b>
80-060-01-04	Hauptfilter für Rauchgasabsaugung marVac® / maXium® smart Vac (ULPA-Standard)	Main filter formarVac® / maXium® smart Vac smoke evacuator (ULPA standard)	Filtro principal para la evacuación de gases de combustión marVac® / maXium® smart Vac (estándar ULPA)
80-811-50-04	Einpedalfußschalter zur manuellen Aktivierung Adapter zum Anschluss an eine zentrale OP-Absaugung (Ø 22 mm)	Single-pedal foot switch for foot activation Adapter for connection to central evacuation system (Ø 22 mm)	Interruptor de pie de pedal simple para la activación con el pie Adaptador para la conexión al sistema de evacuación central del quirófano (Ø 22 mm)

Verbindungsoptionen zur automatischen Aktivierung (HF-Generator oder Laser)		Connection options for automatic activation (via HF generator or laser)	Opciones de conexión para la activación automática (a través del generador de AF o de un equipo láser)
80-091-01-04	MCB-Verbindungskabel (maXium® und maXium® smart Vac)	MCB connecting cable (maXium® and maXium® smart Vac)	Cable de conexión MCB (maXium® y maXium® smart Vac)
80-060-05-04	Adapter zur Netzstromerkennung (ISA-Verbindung), inkl. Verbindungskabel	Adapter for mains current detection (ISA connection), incl. connecting cable	Adaptador para la detección de la corriente de red (conexión ISA), incl. capuchón de fijación
76-100-60-04	Verlängerungskabel maXium® smart Vac, MCO-Laser	Extension cable for maXium® smart Vac, MCO laser	Cable de prolongación para maXium® smart Vac, láser MCO
80-091-02-04	Verbindungskabel ME MB 2/3 mit marVac®/maXium® smart Vac	Connection cable ME MB 2/3 with marVac®/maXium® smart Vac	Cable de conexión ME MB 2/3 con marVac®/maXium® smart Vac
79-800-02-04	Verbindung mit Limax® 60/ diomax® 980/1550	Interlink cable to Limax® 60/ diomax® 980/1550	Cable de interconexión con Limax® 60/ diomax® 980/1550

Weiteres Zubehör für die Rauchgasabsaugung		Additional accessories for smoke evacuator	Accesorios adicionales para el evacuador de gases
79-225-02-04	Trichter, abgeflacht, Verbindung Ø 22 mm, 50 Mal autoklavierbar bei max. 134 °C	Funnel, flattened, connector Ø 22 mm, 50 times autoclavable at max. 134°C (273.2°F)	Embudo, aplanado, conexión Ø 22 mm, autoclavable 50 veces a máx. 134 °C
79-225-03-04	Absaugrohr für Absaugschlauch Ø 22 mm, 50 mal autoklavierbar bei max. 134 °C	Suction tube for suction hose, Ø 22 mm, 50 times autoclavable at max. 134°C (273.2°F)	Tubo de aspiración para la manguera de aspiración de Ø 22 mm, autoclavable 50 veces a máx. 134 °C
79-225-06-04	Schlauchverbinder Ø 22 mm auf Ø 10 mm, 50 Mal autoklavierbar bei max. 134 °C	Hose coupling, Ø 22 mm (f) and Ø 10 mm, 50 times autoclavable at max. 134°C (273.2°F)	Pieza de unión para mangueras, Ø 22 mm a Ø 10 mm, autoclavable 50 veces a máx. 134 °C
79-225-07-04	Schlauchverbinder Ø 22 mm auf Ø 22 mm (m), 50 mal autoklavierbar bei max. 134 °C	Hose coupling, Ø 22 mm (f) and Ø 22 mm, (50 times autoclavable at max. 134°C (273.2°F)	Pieza de unión para mangueras, Ø 22 mm a Ø 22 mm, autoclavable 50 veces a máx. 134 °C
79-225-08-04	Absaugschlauch Ø 22 mm, Länge = 3 m, 50 Mal autoklavierbar bei max. 134 °C	Suction hose, Ø 22 mm, length = 3 m, 50 times autoclavable at max. 134°C (273.2°F)	Manguera de aspiración, Ø 22 mm, longitud = 3 m, autoclavable 50 veces a máx. 134 °C
79-225-09-04	Absaugschlauch Ø 10 mm, Länge = 2 m, 50 Mal autoklavierbar bei max. 134 °C	Suction hose, Ø 10 mm, length = 2 m, 50 times autoclavable at max. 134°C (273.2°F)	Manguera de aspiración, Ø 10 mm, longitud = 2 m, autoclavable 50 veces a máx. 134 °C
79-225-10-04	Steriler Absaugschlauch Ø 22 mm, zur Einmalverwendung (Verpackungseinheit = 25 Stück)	Suction hose, sterile, Ø 22 mm, single-use (pack of 25 items)	Manguera de aspiración, estéril, Ø 22 mm, de un solo uso (unidad de embalaje = 25 unidades)
79-225-11-04	Vorfilter (HEPA-Standard), Ø 22 mm, steril, zum Einmalgebrauch (Verpackungseinheit = 20 Stück)	Prefilter (HEPA standard), Ø 22 mm, sterile, single-use (pack of 20 items)	Filtro previo (estándar HEPA), Ø 22 mm, estéril, de un solo uso (unidad de embalaje = 20 unidades)
80-060-04-04	Absaugschlauch, steril, Ø 10 mm mit Luer-Lock-Anschluss, Länge = 2,5 m, (z.B. zum Anschluss an Trokar) (Verpackungseinheit = 20 Stück)	Air hose, sterile, Ø 10 mm with Luer-Lock connection, 2.5 m long, (e.g. for connection of trocar) (packaging unit = 20 pieces)	Manguera de aspiración, esteril, Ø 10 mm con conector Luer-Lock longitud = 2,5 m (por ej., para la conexión al trocar) (unidad de embalaje = 20 piezas)



Accessoires		Accessori	
	<b>Accessoires en option</b>		<b>Accessori individuali</b>
80-060-01-04	Filtre principal pour évacuateur de fumée marVac®/maXium® smartVa (norme ULPA)		Filtro principale per l'aspiratore di fumo marVac®/maXium® smart Vac (standard ULPA)
80-811-50-04	Interrupteur à une pédale pour activation à l'aide d'une pédale Adaptateur de raccordement à un système central d'évacuation (Ø 22 mm)		Interruttore monopedale per l'attivazione a pedale  Collegamento all'aspirazione centralizzata della sala operatoria (Ø 22 mm)
	<b>Options de connexion pour activation automatique (via générateur HF ou laser)</b>		<b>Opzioni di collegamento per l'attivazione automatica (tramite generatore AF o apparecchio laser)</b>
80-091-01-04	Câble de connexion MCB (maXium® et maXium® smart Vac)		Cavo di collegamento MCB (maXium® e maXium® smart Vac)
80-060-05-04	Adaptateur de détection de courant secteur (connexion ISA), câble de connexion compris		Adattatore di rilevamento della corrente di rete (collegamento ISA), compreso cavo di collegamento
76-100-60-04	Rallonge maXium® smart Vac, laser MCO		Cavo di prolunga per maXium® smart Vac, laser MCO
80-091-02-04	Câble de connexion ME MB 2/3 avec marVac®/maXium® smart Vac		Cavo di collegamento ME MB 2/3 con marVac®/maXium® smart Vac
79-800-02-04	Câble de interconnexion vers Limax® 60/ diomax® 980/1550		Cavo d'interconnessione da Limax® 60/ diomax® 980/1550
	<b>Autres accessoires pour évacuateur de fumée</b>		<b>Ulteriori accessori per l'aspirazione di fumo</b>
79-225-02-04	Entonnoir, aplati, raccord Ø 22 mm, 50 x autoclavable à max. 134 °C		Imbutto, spianato, collegamento di Ø 22 mm, autoclavabile per 50 volte ad una temperatura di max. 134 °C
79-225-03-04	Tube d'aspiration pour tuyau d'aspiration Ø 22 mm, 50 x autoclavable à max. 134 °C		Tubo di aspirazione per tubo flessibile di aspirazione di Ø 22 mm, autoclavabile per 50 volte ad una temperatura di max. 134 °C
79-225-06-04	Raccord de tuyau Ø 22 mm sur Ø 10 mm, 50 x autoclavable à max. 134 °C		Raccordo per tubo flessibile di Ø 22 mm su Ø 10 mm, autoclavabile per 50 volte ad una temperatura di max. 134 °C
79-225-07-04	Raccord de tuyau Ø 22 mm sur Ø 22 mm, 50 x autoclavable à max. 134 °C		Raccordo per tubo flessibile di Ø 22 mm su Ø 22 mm, autoclavabile per 50 volte ad una temperatura di max. 134 °C
79-225-08-04	Tuyau d'aspiration Ø 22 mm, longueur = 3 m, 50 x autoclavable à max. 134 °C		Tubo flessibile di aspirazione di Ø 22 mm, lunghezza = 3 m, autoclavabile per 50 volte ad una temperatura di max. 134 °C
79-225-09-04	Tuyau d'aspiration Ø 10 mm, longueur = 2 m, 50 x autoclavable à max. 134 °C		Tubo flessibile di aspirazione di Ø 10 mm, lunghezza = 2 m, autoclavabile per 50 volte ad una temperatura di max. 134 °C
79-225-10-04	Tuyau d'aspiration, stérile, Ø 22 mm, à usage unique (UE = 25 pièces)		Tubo flessibile di aspirazione, sterile, Ø 22 mm, monouso (unità di imballaggio = 25 unità)
79-225-11-04	Préfiltre (norme HEPA), Ø 22 mm, stérile, à usage unique (UE = 20 pièces)		Prefiltro (standard HEPA), Ø 22 mm, sterile, monouso (unità di imballaggio = 20 unità)
80-060-04-04	Tuyau d'aspiration, stérile, Ø 10 mm avec raccord Luer-Lock, longueur = 2,5 m, (par exemple pour le raccordement au trocart) (unité d'emballage = 20 pièces)		Tubo flessibile di aspirazione di Ø 10 mm, sterile, con raccordo Luer-Lock, lunghezza = 2,5 m, (per esempio per il collegamento al trequarto) (unità di imballaggio = 20 unità)





80-060-03-04 *max. 4100 V<sub>p</sub>* **STERILE IEO**

Elektrodenhandgriff mit Elektrode Ø 2,4 mm und 3-Pin-Stecker mit aufgesetztem Clip-on-Applikator, steril, zum Einmalgebrauch, Schlauchlänge = 3 m, Schlauchdurchmesser 22 mm (Verpackungseinheit = 12 Stück)

Electrode handle with electrode Ø 2.4 mm and 3-pin plug, with attached clip-on applicator, sterile, for single use only, hose length 3 m, hose diameter 22 mm (12 items/pack)

Mango portaelectrodos con electrodo de Ø 2,4 mm y clavija de tres alfileres, con aplicador clip-on colocado, estéril, de un solo uso, longitud de la manguera = 3 m, diámetro de la manguera 22 mm (12 unidades/envase)

Manche porte-électrode avec électrode Ø 2,4 mm et fiche à 3 broches, avec applicateur « clip-on » sur le dessus, stérile, à usage unique, longueur du tuyau = 3 m, diamètre du tuyau 22 mm (unité d'emballage = 12 pièces)

Impugnatura per elettrodi con elettrodo Ø 2,4 mm e spina a 3 pin, con applicatore clip-on applicato, sterile, monouso, lunghezza tubo flessibile 3 m, diametro tubo flessibile 22 mm (unità di imballaggio = 12 pezzi)



80-060-02-04 *max. 4000 V<sub>p</sub>* **STERILE|EO**

Clip-on-Applikator, steril, zum Einmalgebrauch, Schlauchlänge = 3 m, Ø 22 mm zur Verwendung mit den wiederverwendbaren Elektrodenhandgriffen KLS Martin 80-217-XX und 80-210-12-04 (Verpackungseinheit = 12 Stück)\*

Clip-on applicator, sterile, single-use, tubing length 3 m, Ø 22 mm, for use with the reusable KLS Martin electrode handles 80-217-XX and 80-210-12-04 (12 items/pack)\*

Aplicador "clip-on", estéril, de un solo uso, longitud de manguera 3 m, Ø 22 mm, a utilizar con los mangos portaelectrodos reutilizables de KLS Martin 80-217-XX y 80-210-12-04 (UE = 12 unidades)\*

Applicateur « clip-on », stérile, à usage unique, longueur du tuyau 3 m, Ø 22 mm, pour utilisation avec porte-électrode à usage multiple KLS Martin 80-217-XX et 80-210-12-04 (UE = 12 pièces)\*

Applicatore "clip-on", sterile, monouso, lunghezza tubo flessibile 3 m, Ø 22 mm, da usare con le impugnature riutilizzabili per elettrodi KLS Martin 80-217-XX e 80-210-12-04 (UV = 12 unità)\*

\* Die Elektrodenhandgriffe sind nicht im Lieferumfang enthalten und müssen separat bestellt werden.

The electrode handles are not included in the scope of supply and therefore must be ordered separately.

Los mangos portaelectrodos no forman parte de las prestaciones del suministro, debiéndolos encargar por separado.

Les Manches porte-électrodes ne sont pas comprises dans la livraison et doivent être commandées séparément.

Le impugnature per elettrodi non sono comprese nella fornitura e devono essere ordinate separatamente.





# smartLap



HF-Anschlusskabel (ø 4 mm)  
HF connection cord (ø 4 mm)  
Cable de conexión AF (ø 4 mm)  
Câble de raccordement HF (ø 4 mm)  
Cavo di collegamento AF (ø 4 mm)

Hochwertige Isolierung  
Premium quality isolation  
Aislación de alta calidad  
Isolation de grande qualité  
Isolamento di alta qualità

Anschluss für Absaugschlauch  
Connector for suction hose  
Conexión para tubo de aspiración  
Connexion pour tube d'aspiration  
Collegamento per tubo d'aspiratore

Integrierter Absaugkanal  
Integrated evacuation channel  
Canal de aspiración integrado  
Conduite d'évacuation intégrée  
Canale di aspirazione integrato

Geriffelter Handgriff  
Corrugated handpiece  
Mango corrugado  
Poignée cannelée  
Impugnatura scanalata

8

maXium®

maXium® smart Vac/  
marVac®



Sample illustration



1/3



1/3

83-120-50-04 **max. 4000 V<sub>p</sub>**

5 m  
Anschlusskabel  
Connection cable  
Cable de conexión  
Câble de raccordement  
Cavo di connessione

83-120-51-04 **max. 4000 V<sub>p</sub>**

5 m  
Anschlusskabel  
Connection cable  
Cable de conexión  
Câble de raccordement  
Cavo di connessione



Weitere Informationen entnehmen Sie bitte der separaten Broschüre.

For further information please refer to our separate product brochure.

Encontrará informaciones adicionales en el folleto individual.

Vous trouverez des informations supplémentaires dans la brochure.

Per ulteriori informazioni vedasi il prospetto separato.

# 9

Hochfrequenzchirurgie-Geräte  
Electrosurgery units  
Aparatos electroquirúrgicos  
Bistouris electrochirurgicaux  
Apparecchi elettrochirurgici



## maXium®



80-092-00-04

maXium®

Kabelset für Software Update maXium®  
 Cable set for maXium® software update  
 Kit de cables para actualización de software maXium®  
 Kit de câbles pour mise à jour logiciel maXium®  
 Set di cavi per aggiornamento software maXium®

80-042-00-04

maXium® m

(100-240 V)

80-042-02-04

maXium® i

(100-240 V)

80-042-04-04

maXium® e

(100-240 V)

80-093-00-04

maXium®

Option bipolare Resektion  
 Bipolar resection option  
 Opción resección bipolar  
 Option résection bipolaire  
 Opzione resezione bipolare

80-093-01-04

maXium®

Option Einbindung in OR1 NEO/Karl Storz  
 Option integration into Karl Storz OR1 NEO system  
 Opción de integración en el sistema OR1 NEO/Karl Storz  
 Option intégration dans le système OR1 NEO/Karl Storz  
 Opzione integrazione nel sistema OR1 NEO/Karl Storz

80-093-02-04

maXium®

Option Einbindung in CORE nova®/Richard Wolf  
 Option integration into CORE nova®/Richard Wolf system  
 Opción de integración en el sistema CORE nova®/Richard Wolf  
 Option intégration dans le système CORE nova®/Richard Wolf  
 Opzione integrazione nel sistema CORE nova®/Richard Wolf

## maXium® Beamer



80-044-00-04

maXium® Beamer

Nur zur Verwendung mit dem maXium®-Generator  
 For use only with the maXium® generator  
 Utilícese sólo con generador maXium®  
 A n'utiliser qu'avec générateur maXium®  
 Solo per l'utilizzo con generatore maXium®



## maXium® smart C



80-043-00-04  
maXium® smart C **m**  
(100-240 V)

80-043-01-04  
maXium® smart C **i**  
(100-240 V)

80-043-02-04  
maXium® smart C **e**  
(100-240 V)

80-094-00-04  
maXium® smart C  
Option SWAP-Mode  
Option SWAP mode  
Opción modo SWAP  
Option mode SWAP  
Opzione modo SWAP

80-094-01-04  
maXium® smart C  
Option Duo-Prep, Duo-Spray  
Option Duo-Prep, Duo-Spray  
Opción Duo-Prep, Duo-Spray  
Option Duo-Prep, Duo-Spray  
Opzione Duo-Prep, Duo-Spray

80-094-02-04  
maXium® smart C  
Option Neptun  
Option Neptun  
Opción Neptun  
Option Neptun  
Opzione Neptun



reddot award 2016  
winner



Focus Open 2016  
Special Mention

## maXium® smart Beam



80-043-10-04

Nur zur Verwendung mit den maXium®-smart-Generatoren  
For use only with the maXium® smart generators  
Utilícese sólo con generadores maXium® smart  
A n'utiliser qu'avec générateurs maXium® smart  
Solo per l'utilizzo con generatori maXium® smart

## ME MB 3



80-040-11-04  
ME MB 3 **m**  
(220-240 V)

80-040-12-04  
ME MB 3 **i**  
(220-240 V)

80-040-11-10  
ME MB 3 **m**  
(100-127 V)

80-040-12-10  
ME MB 3 **i**  
(100-127 V)

## ME 102



80-010-02-04  
(230 V)

80-010-02-12  
(115 V)





## miniCutter



80-008-03-04  
(100-240 V)

## MD 62



80-006-02-04  
(230 V)

Für weitere Informationen fordern Sie bitte die jeweilige Broschüre an.  
If you require more information please request the appropriate brochure.  
Para más información, solicite el folleto correspondiente.  
N'hésitez pas à demander à recevoir la brochure correspondante pour obtenir de plus amples informations.  
Per ulteriori informazioni, richiedere le rispettive brochure.

Unit	Max. Output	Monopolar	Bipolar	Benutzer- oberfläche	Aktivierung	NE - Modes	Argon-Gas	Rauchgas- absaugung	Gefäßver- siegelung
<b>MD 62</b>	<b>Monopolar</b> 50 Watt (Cut) 30 Watt (Coag)	1 Cut 1 Coag	-	Analoganzeige (Drehregler)	Elektroden-Handgriff mit einer Taste oder Einpedal- Fußschalter, pneumatisch	Handzylinder- Neutral- elektrode		maXium® smart Vac oder marVac® mit iDetect	
<b>miniCutter</b>	<b>Monopolar</b> 80 Watt (Cut) 70 Watt (Coag)  <b>Bipolar</b> 70 Watt	2 Cut 2 Coag	1 Coag	Analoganzeige (Drehregler)	<b>Monopolar</b> Elektroden-Handgriff mit einer Taste oder Einpedal-Fußschalter  <b>Bipolar</b> Aktivierung nur über Einpedal-Fußschalter			maXium® smart Vac oder marVac® mit iDetect	
<b>ME 102</b>	<b>Monopolar</b> 100 Watt (Cut) 70 Watt (Coag)  <b>Bipolar</b> 80 Watt	2 Cut 1 Coag	1 Coag	Analoganzeige (Drehregler)	<b>Monopolar</b> Elektroden-Handgriff oder Fußschalter  <b>Bipolar</b> Aktivierung über Fußschalter oder über „Auto-Start“-Funktion			maXium® smart Vac oder marVac® mit iDetect	
<b>ME MB 1</b>	<b>Monopolar</b> 400 Watt (Cut) 250 Watt (Coag)  <b>Bipolar</b> 100 Watt	3 Cut 2 Coag	1 Coag	Analoganzeige (Drehregler)	<b>Monopolar</b> Elektroden-Handgriff oder Fußschalter  <b>Bipolar</b> Aktivierung nur über Fußschalter		MB 181	maXium® smart Vac oder marVac® mit iDetect	
<b>ME MB 3</b>	<b>Monopolar</b> 400 Watt (Cut) 250 Watt (Coag)  <b>Bipolar</b> 100 Watt	4 Cut 3 Coag	1 Coag	Digitalanzeige (Drehregler)	<b>Monopolar</b> Elektroden-Handgriff oder Fußschalter  <b>Bipolar</b> Aktivierung über Fußschalter oder über „Auto-Start“- Funktion		MB 181	maXium® smart Vac oder marVac® mit iDetect	
<b>maXium® smart C</b>	<b>Monopolar</b> 400 Watt (Cut) 200 Watt (Coag)  <b>Bipolar</b> 120 Watt (Cut) 250 Watt (Coag)	6 Cut 9 Coag	2 Cut 2 Coag	Digitalanzeige (Touch-Screen Display)	<b>Monopolar</b> Elektroden-Handgriff oder Fußschalter  Bipolar: Aktivierung über Fußschalter oder über „Auto-Start“- Funktion	 <b>Baby</b> <b>Mega</b>	maXium® smart Beam	maXium® smart Vac	
<b>maXium®</b>	<b>Monopolar</b> 360 Watt (Cut) 150 Watt (Coag)  <b>Bipolar</b> 120 Watt (Cut) 320 Watt (Coag)	13 Cut 17 Coag	7 Cut 13 Coag	Digitalanzeige (Display mit Drehregler)	<b>Monopolar</b> Elektroden-Handgriff oder Fußschalter  <b>Bipolar</b> Aktivierung über Fußschalter oder über Fingerschalter. Alternativ über „Auto-Start“-Funktion	 <b>Baby</b> <b>Mega</b>	maXium® Beamer	marVac® oder maXium® smart Vac mit maXium® smart Cart	SealSafe IQ

Übersicht  
Anschlusskabel

Großer Koaxialstecker

Kleiner Koaxialstecker

Erbe Koaxialstecker Ø 8 mm

US-3-PIN-Stecker





TUR	Schnittstelle für HF-Zubehör	Anwendungsbereiche																			
		Allgemeinchirurgie	Dentalchirurgie	Dermatologie	Gastroenterologie	Gynäkologie	Herz- und Gefäßchirurgie	HNO-Chirurgie	Mund-, Kiefer- und Gesichtschirurgie	Neurochirurgie	Urologie	Viszeralchirurgie									
	<b>1 monopolarer Ausgang</b> • Großer Koaxialstecker	x																			
	<b>1 monopolarer Ausgang</b> • Großer Koaxialstecker  <b>1 bipolarer Ausgang</b> • Kleiner Koaxialstecker	x	x	x						x	x										
	<b>1 monopolarer Ausgang</b> • Großer Koaxialstecker • US-3-PIN-Stecker  <b>1 bipolarer Ausgang</b> • Kleiner Koaxialstecker	x	x	x						x	x										
mono- polare TUR	<b>1 monopolarer Ausgang</b> • Großer Koaxialstecker • US-3-PIN-Stecker  <b>1 bipolarer Ausgang</b> • Kleiner Koaxialstecker	x						x	x										x	x	
mono- polare TUR	<b>m-Version</b> <b>1 monopolarer Ausgang</b> • Großer Koaxialstecker • US-3-PIN-Stecker • Bananenstecker  <b>1 bipolarer Ausgang</b> • US-2-PIN-Flachstecker • Kleiner Koaxialstecker	<b>i-Version</b> <b>1 monopolarer Ausgang</b> • US-3-PIN-Stecker • Bananenstecker  <b>1 bipolarer Ausgang</b> • US-2-PIN-Flachstecker • Kleiner Koaxialstecker	x							x	x								x	x	
mono- polare TUR	<b>m-Version</b> <b>2 monopolare Ausgänge</b> • Großer Koaxialstecker • US-3-PIN-Stecker • Bananenstecker  <b>1 bipolarer Ausgang</b> • US-2-PIN-Flachstecker • Kleiner Koaxialstecker • Bananenstecker	<b>i-Version</b> <b>2 monopolare Ausgänge</b> • Bovie-Stecker • US-3-PIN-Stecker • Bananenstecker  <b>1 bipolarer Ausgang</b> • US-2-PIN-Flachstecker • Großer Koaxialstecker • Bananenstecker	<b>e-Version</b> <b>2 monopolare Ausgänge</b> • Erbe-Koaxialstecker • US-3-PIN-Stecker • Bananenstecker  <b>1 bipolarer Ausgang</b> • US-2-PIN-Flachstecker • Großer Koaxialstecker • Bananenstecker	x						x	x	x	x	x	x	x	x				
Bipolare TUR und mono- polare TUR	<b>m-Version</b> <b>2 monopolare Ausgänge</b> • Großer Koaxialstecker • US-3-PIN-Stecker • Bananenstecker  <b>2 bipolare Ausgänge</b> • US-2-PIN-Flachstecker • Kleiner Koaxialstecker • Bananenstecker • IQ-Stecker	<b>i-Version</b> <b>2 monopolare Ausgänge</b> • Bovie-Stecker • US-3-PIN-Stecker • Bananenstecker  <b>2 bipolare Ausgänge</b> • US-2-PIN-Flachstecker • Bananenstecker • IQ-Stecker	<b>e-Version</b> <b>2 monopolare Ausgänge</b> • Erbe-Koaxialstecker • US-3-PIN-Stecker • Bananenstecker  <b>2 bipolare Ausgänge</b> • US-2-PIN-Flachstecker • Großer Koaxialstecker • Bananenstecker • IQ-Stecker	x						x	x	x	x	x	x	x	x				



Unit	Max. Output	Monopolar	Bipolar	User interface	Activation	NE-mode	Argon gas	Smoke evacuator	Vessel sealing
<b>MD 62</b>	<b>Monopolar</b> 50 Watt (Cut) 30 Watt (Coag)	1 Cut 1 Coag	-	Analog display (Rotary switch)	Electrode handle with one pushbutton or single-pedal foot switch, pneumatic	Hand cylinder neutral electrode		maXium® smart Vac or marVac® with iDetect	
<b>miniCutter</b>	<b>Monopolar</b> 80 Watt (Cut) 70 Watt (Coag)  <b>Bipolar</b> 70 Watt	2 Cut 2 Coag	1 Coag	Analog display (Rotary switch)	<b>Monopolar</b> Electrode handle with one pushbutton or single- pedal foot switch  <b>Bipolar</b> Only with single-pedal foot switch			maXium® smart Vac or marVac® with iDetect	
<b>ME 102</b>	<b>Monopolar</b> 100 Watt (Cut) 70 Watt (Coag)  <b>Bipolar</b> 80 Watt	2 Cut 1 Coag	1 Coag	Analog display (Rotary switch)	<b>Monopolar</b> Electrode handle or foot switch  <b>Bipolar</b> Foot switch or „Auto-Coag-Start“ function			maXium® smart Vac or marVac® with iDetect	
<b>ME MB 1</b>	<b>Monopolar</b> 400 Watt (Cut) 250 Watt (Coag)  <b>Bipolar</b> 100 Watt	3 Cut 2 Coag	1 Coag	Analog display (Rotary switch)	<b>Monopolar</b> Electrode handle or foot switch  <b>Bipolar</b> Only with foot switch		MB 181	maXium® smart Vac or marVac® with iDetect	
<b>ME MB 3</b>	<b>Monopolar</b> 400 Watt (Cut) 250 Watt (Coag)  <b>Bipolar</b> 100 Watt	4 Cut 3 Coag	1 Coag	Digital display (Rotary switch)	<b>Monopolar</b> Electrode handle or foot switch  <b>Bipolar</b> Foot switch or „Auto-Coag-Start“ function		MB 181	maXium® smart Vac or marVac® with iDetect	
<b>maXium® smart C</b>	<b>Monopolar</b> 400 Watt (Cut) 200 Watt (Coag)  <b>Bipolar</b> 120 Watt (Cut) 250 Watt (Coag)	6 Cut 9 Coag	2 Cut 2 Coag	Digital display (Touch-Screen Display)	<b>Monopolar</b> Electrode handle or foot switch  <b>Bipolar</b> Foot switch or „Auto-Coag-Start“ function	  <b>Baby</b>  <b>Mega</b>	maXium® smart Beam	maXium® smart Vac	
<b>maXium®</b>	<b>Monopolar</b> 360 Watt (Cut) 150 Watt (Coag)  <b>Bipolar</b> 120 Watt (Cut) 320 Watt (Coag)	13 Cut 17 Coag	7 Cut 13 Coag	Digital display (Display with Rotary switch)	<b>Monopolar</b> Electrode handle or foot switch  <b>Bipolar</b> Foot switch/ hand activation or „Auto-Coag-Start“ function	  <b>Baby</b>  <b>Mega</b>	maXium® Beamer	marVac® or maXium® smart Vac with maXium® smart Cart	SealSafe IQ

**Overview  
connectin cables**

Big coaxial plug



Small coaxial plug



Erbe coaxial plug Ø 8 mm



US-3-PIN plug





Bipolar resection	Connection socket for HF accessories																				
		Cardiovascular surgery	Dental surgery	Dermatology	ENT surgery	Gastroenterology	General surgery	Gynaecology	Oral and Craniofacial surgery	Neuro surgery	Urology	Visceral surgery									
	<b>1 monopolar output</b> • Big coaxial plug	x																			
	<b>1 monopolar output</b> • Big coaxial plug  <b>1 bipolar output</b> • Small coaxial plug	x	x	x		x				x											
	<b>1 monopolar output</b> • Big coaxial plug • US-3-PIN plug  <b>1 bipolar output</b> • Small coaxial plug	x	x	x		x				x											
mono-polar TUR	<b>1 monopolar output</b> • Big coaxial plug • US-3-PIN plug  <b>1 bipolar output</b> • Small coaxial plug								x	x	x							x	x		
mono-polar TUR	<b>m-Version</b> <b>1 monopolar output</b> • Big coaxial plug • US-3-PIN plug • Banana plug  <b>1 bipolar output</b> • US-2-PIN plug • Small coaxial plug																				
	<b>i-Version</b> <b>1 monopolar output</b> • US-3-PIN plug • Banana plug  <b>1 bipolar output</b> • US-2-PIN plug • Small coaxial plug								x	x	x							x	x		
mono-polar TUR	<b>m-Version</b> <b>2 monopolar outputs</b> • Big coaxial plug • US-3-PIN plug • Banana plug  <b>1 bipolar output</b> • US-2-PIN plug • Small coaxial plug • Banana plug	x						x													
	<b>i-Version</b> <b>2 monopolar outputs</b> • Bovie plug • US-3-PIN plug • Banana plug  <b>1 bipolar output</b> • US-2-PIN plug • Big coaxial plug • Banana plug																				
	<b>e-Version</b> <b>2 monopolar outputs</b> • Erbe coaxial plug • US-3-PIN plug • Banana plug  <b>1 bipolar output</b> • US-2-PIN plug • Big coaxial plug • Banana plug																				
Bipolar TUR and mono-polar TUR	<b>m-Version</b> <b>2 monopolar outputs</b> • Big coaxial plug • US-3-PIN plug • Banana plug  <b>2 bipolar outputs</b> • US-2-PIN plug • Small coaxial plug • Banana plug • IQ plug	x																			
	<b>i-Version</b> <b>2 monopolar outputs</b> • Bovie plug • US-3-PIN plug • Banana plug  <b>2 bipolar outputs</b> • US-2-PIN plug • Banana plug • IQ plug																				
	<b>e-Version</b> <b>2 monopolar outputs</b> • Erbe coaxial plug • US-3-PIN plug • Banana plug  <b>2 bipolar outputs</b> • US-2-PIN plug • Big coaxial plug • Banana plug • IQ plug																				





#### 80-105-00-04

Prüfgerät marTest bestehend aus:

- Prüfergerät marTest
- Netzteil Europa, 100-240 V
- Leitungssatz zur Isolationsprüfung für MIC-Instrumente mit 4-mm-Anschluss
- Koffer zur Aufbewahrung

marTest tester comprised of:

- marTest tester
- Power supply unit Europe, 100-240 V
- Cable set for insulation testing on MIS instruments with 4 mm socket
- Storage case

Comprobador marTest compuesto por:

- Comprobador marTest
- Fuente de alimentación, Europa, 100-240 V
- Juego de cables para la comprobación del aislamiento para instrumentos CMI con conexión de 4 mm
- Maletín (para guardar el aparato)

Dispositif testeur marTest, comprenant

- Appareil testeur marTest
- Bloc d'alimentation, Europe, 100-240 V
- Lot de câbles pour vérification de l'isolation des instruments de chirurgie mini-invasive, avec connecteur de 4-mm
- Mallette de rangement

Apparecchio di prova marTest composto da:

- Apparecchio di prova marTest
- Alimentatore, Europa, 100-240 V
- Set di cavi per prova di isolamento di strumenti per chirurgia mininvasiva con presa di 4 mm
- Valigetta per conservazione

**Optionales Zubehör**  
**Optional accessories**  
**Accesorios opcionales**  
**Accessoires en option**  
**Accessori opzionali**



#### 80-105-01-04

Adapter zur Isolationsprüfung für bipolare Instrumente mit europäischem Flachpin-Stecker

Adapter for insulation testing on bipolar instruments with European flat-pin connector

Adaptador para la comprobación del aislamiento para instrumentos bipolares con clavija de pin plano europea

Adaptateur pour vérification de l'isolation des instruments bipolaires avec connecteur pin plat européen

Adattatore per prova di isolamento di strumenti bipolari con connettore a spina piatta europea



#### 80-105-02-04

Adapter zur Prüfung bipolares Resektoskopkabel Karl Storz (Art.-Nr. 80-287-96-04)

Adapter for testing bipolar resectoscope cable Karl Storz (item no. 80-287-96-04)

Adaptador para la comprobación del cable de resectoscopia bipolar Karl Storz (n.º art. 80-287-96-04)

Adaptateur pour contrôle du câble pour résectoscope bipolaires Karl Storz (réf. 80-287-96-04)

Adattatore per la prova del cavo di resectoscopia bipolare Karl Storz (codice 80-287-96-04)



#### 80-105-05-04

Leitungssatz zur Isolationsprüfung von MIC-Instrumenten mit 4-mm-Anschluss (bereits im Lieferumfang von Art. 80-105-00-04 enthalten)

Cable set for insulation testing on MIS instruments with 4-mm socket (already included with art. 80-105-00-04)

Juego de cables para la comprobación del aislamiento para instrumentos CMI con conexión de 4 mm (ya incluido en el volumen de suministro del art. 80-105-00-04)

Lot de câbles pour vérification de l'isolation des instruments de chirurgie mini-invasive, avec connecteur de 4 mm (déjà fourni avec l'article 80-105-00-04)

Set di cavi per prova di isolamento di strumenti per chirurgia mininvasiva con presa di 4 mm (già presente nella dotazione dell'art. 80-105-00-04)



#### 80-105-03-04

Netzteil Europa, 100 -240 V (bereits im Lieferumfang von Art. 80-105-00-04 enthalten)

Power supply Europe, 100-240 V (already included with art. 80-105-00-04)

Fuente de alimentación Europa, 100-240 V (ya incluido en el volumen de suministro del art. 80-105-00-04)

Bloc d'alimentation Europe, 100-240 V (déjà fourni avec l'article 80-105-00-04)

Alimentatore Europa, 100 -240 V (già presente nella dotazione dell'art. 80-105-00-04)

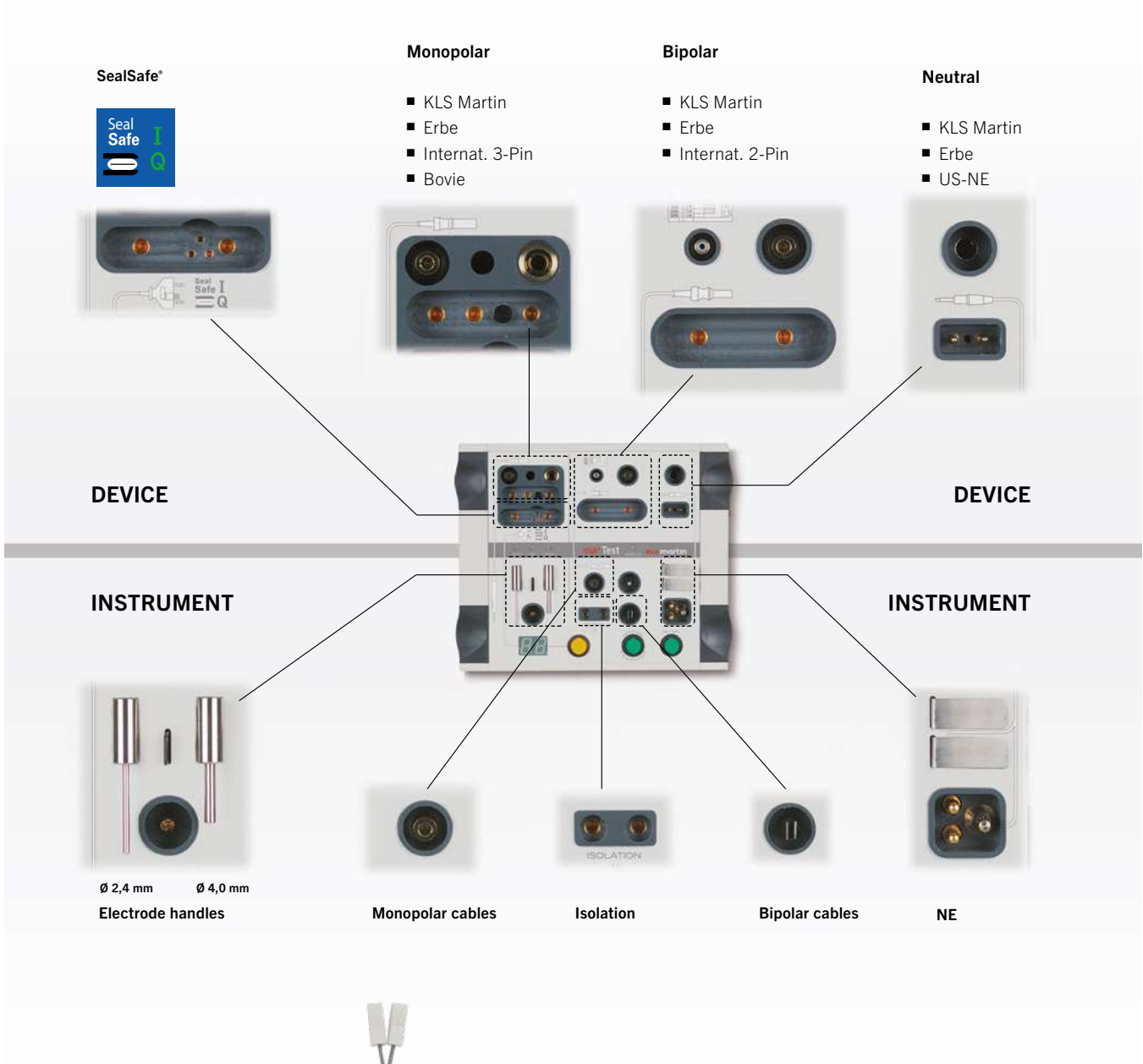

9



80-105-06-04  
Adapter zur Isolationsprüfung für bipolare Robi-Pinzetten  
Adapter for insulation testing on bipolar Robi forceps  
Adaptador para ensayos de aislamiento en pinzas bipolares Robi  
Adaptateur de test d'isolation sur pinces Robi bipolaires  
Adattatore per prova di isolamento di pinze bipolari Robi



80-105-07-04  
Adapter zur Isolationsprüfung für bipolare Aesculap-Pinzetten  
Adapter for insulation testing on bipolar Aesculap forceps  
Adaptador para ensayos de aislamiento en pinzas bipolares Aesculap  
Adaptateur de test d'isolation sur pinces Aesculap bipolaires  
Adattatore per prova di isolamento di pinze bipolari Aesculap



Weitere Informationen entnehmen Sie bitte der separaten Broschüre.  
For further information please refer to our separate product brochure.  
Encontrará informaciones adicionales en el folleto individual.  
Vous trouverez des informations supplémentaires dans la brochure.  
Per ulteriori informazioni vedasi il prospetto separato.

Geräte zur Funktionsprüfung  
Function testers  
Aparatos para la comprobación del funcionamiento  
Appareils de contrôle de fonctionnement  
Apparecchi per prova di funzionamento

---

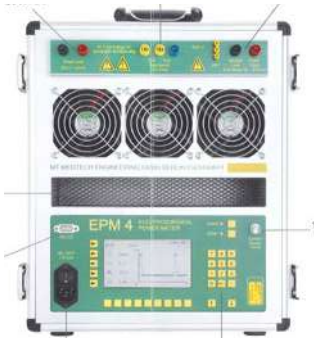

80-103-00-04

EPM 4

Leistungsmesskoffer mit Software  
Portable power meter with software  
Maleta para medir la potencia con software  
Coffre pour mesurer la puissance avec software  
Cofano per misurare la potenza con software

**Messkabel für EPM 4**

**Test cable for EPM 4**

**Cable de medición para EPM 4**

**Câble de mesure pour EPM 4**

**Cavo di misurazione per EPM 4**

08-008-00-06

Messkabel Neutralelektrode KLS Martin  
Test cable for KLS Martin neutral electrode  
Cable de medición para placa neutra de KLS Martin  
Câble de mesure pour électrode neutre KLS Martin  
Cavo di misurazione per elettrodo neutro KLS Martin

08-008-00-08

Messkabel monopolar KLS Martin  
Test cable, monopolar KLS Martin  
Cable de medición monopolar KLS Martin  
Câble de mesure monopolaire KLS Martin  
Cavo di misurazione monopolare KLS Martin

08-008-00-04

Messkabel Fußschalter monopolar für Großgeräte  
Test cable for monopolar foot switch for major HF units  
Cable de medición para interruptor de pie monopolar para equipos de AF grandes  
Câble de mesure pour interrupteur à pédale monopolaire pour grands appareils  
Cavo di misurazione per interruttore a pedale monopolare per grandi apparecchi AF

08-008-00-14

Messkabel bipolar KLS Martin / symmetrisch  
Test cable bipolar KLS Martin / symmetrical  
Cable de medición bipolar KLS Martin / simétrico  
Câble de mesure bipolaire KLS Martin / symétrique  
Cavo di misurazione bipolare KLS Martin / simmetrico

08-008-00-10

HF-Prüfadapter  
HF test adapter  
Adaptador de ensayo de AF  
Adaptateur d'essai HF  
Adattatore di prova AF

08-008-00-19

NE-Adapter international auf Klinkenstecker 6,3 mm  
NE adapter international to 6.3-mm plug  
Adaptador EN internacional a conector jack de 6,3 mm  
Adaptateur EN international sur prise jack de 6,3 mm  
Adattatore NE internazionale su connettore jack 6,3 mm

08-008-00-20

Testadapter international auf 4-mm-Buchse  
Test adapter international to 4-mm plug  
Adaptador de prueba internacional a conector hembra de 4 mm  
Adaptateur de test international sur fiche de 4 mm  
Adattatore prova internazionale su presa 4 mm

08-022-00-21

Bipolarer Prüfadapter maXium\* (ab HW 02)  
Bipolar test adapter for maXium\* (from HW 02)  
Adaptador de control bipolar para maXium\* (a partir del HW 02)  
Adaptateur de test bipolaire maXium\* (à partir de HW 02)  
Adattatore di controllo bipolare maXium\* (a partire da HW 02)



# 10

Fußschalter  
Foot switches  
Interruptores de pie  
Interrupteurs à pédale  
Interruttori a pedale





#### 80-811-50-04

Monopolarer und bipolarer Fußschalter, explosionsgeschützt, AP-geprüft, IP X8, eintauchbar

Monopolar and bipolar foot switch, anti-explosive, AP-tested (anesthetics-proof), IP X8, immersible

Interruptor de pie monopolar y bipolar, antiexplosivo, controlada su aptitud para anestésicos, IP X8, sumergible

Interrupteur à pédale monopolaire et bipolaire, anti-explosif, catégorie AP, IP X8, immergeable

Interruttore a pedale monopolare e bipolare, anti-deflagrante, testato AP, IP X8, immergibile

**ME 81 (nur bipolar, bipolar only, sólo bipolar, bipolaire uniquement, solo bipolare)**

**ME K1**

**ME K2**

**ME 82**

**miniCutter**

**ME 102 (nur bipolar, bipolar only, sólo bipolar, bipolaire uniquement, solo bipolare)**



#### 80-812-10-04

Einpedal-Fußschalter, pneumatisch, 2 m Luftschlauch

Single-pedal foot switch, pneumatic, 2-m air hose

Interruptor de pie de un pedal, neumático, manguera de 2 m

Interrupteur à une pédale pneumatique, tuyau à air de 2 m

Interruttore monopedale, pneumatico, con tubo flessibile per l'aria da 2 m

**MD 62**



#### 80-811-04-04

Bipolarer Fußschalter, explosionsgeschützt, AP-geprüft, IP X8, eintauchbar

Bipolar foot switch, anti-explosive, AP-tested (anesthetics-proof), IP X8, immersible

Interruptor de pie, bipolar, antiexplosivo, controlada su aptitud para anestésicos, IP X8, sumergible

Interrupteur à pédale, bipolaire, anti-explosif, catégorie AP, IP X8, immergeable

Interruttore a pedale, bipolare, anti-deflagrante, testato AP, IP X8, immergibile

**ME 81 (nur bipolar, bipolar only, sólo bipolar, bipolaire uniquement, solo bipolare)**

**ME 82**

**miniCutter (nur bipolar, bipolar only, sólo bipolar, bipolaire uniquement, solo bipolare)**

**ME 102 (nur bipolar, bipolar only, sólo bipolar, bipolaire uniquement, solo bipolare)**

Für alle Fußschalter gilt die Kabellänge 5 m (Ausnahme 80-812-10-04)

Cable length for all foot switches: 5 m (exception 80-812-10-04)

Todos los interruptores de pedal usan un cable de 5 m de longitud (excepción 80-812-10-04)

La longueur de câble de 5 m est valable pour tous les interrupteurs à pédale (exception 80-812-10-04)

Il cavo lungo 5 m è indicato per tutti gli interruttori a pedale (eccezione 80-812-10-04)



80-824-01-04

Doppelpedal-Fußschalter, monopolar,  
explosionssgeschützt, AP-geprüft,  
IP X8, eintauchbar

**ME 81**  
**ME 82**  
**ME 102**

Double-pedal foot switch, monopolar,  
explosion- and anesthetics-proof (AP-tested),  
IP X8, immersible

Interruptor de pie de doble pedal, monopolar,  
antiexplosivo, controlada su aptitud para anestésicos,  
IP X8, sumergible

Interrupteur à pédale double, monopolaire,  
anti-explosif, catégorie AP, IP X8, immergeable

Interruttore a pedale doppio, monopolare,  
anti-deflagrante, testato AP, IP X8, immergibile



**NON-CE**

80-823-02-04

Doppelpedal-Fußschalter, monopolar,  
kein AP-Schutz, nicht für OP-Bereich geeignet

**ME 81**  
**ME 102**

Double-pedal foot switch, monopolar,  
not anesthetics-proof (AP), not suitable for use  
in operating area

Interruptor de pie de doble pedal, monopolar,  
no apto para anestésicos, inapropiado para el  
ámbito del quirófano

Interrupteur à pédale double, monopolaire,  
pas résistant aux produits anesthésiques,  
ne convient pas pour une utilisation en salle  
d'opération

Interruttore a pedale doppio, monopolare,  
senza protezione AP, non adatto all'uso in  
sala operatoria

Für alle Fußschalter gilt die Kabellänge 5 m  
Cable length for all foot switches: 5 m  
Todos los interruptores de pedal usan un cable de 5 m de longitud  
La longueur de câble de 5 m est valable pour tous les interrupteurs à pédale  
Il cavo lungo 5 m è indicato per tutti gli interruttori a pedale



80-821-02-04

Doppelpedal-Fußschalter, explosionsgeschützt, AP-geprüft, IP X8, eintauchbar  
 Double-pedal foot switch, explosion- and anesthetics-proof (AP-tested), IP X8, immersible  
 Interruptor de pie de doble pedal, antiexplosivo, controlada su aptitud para anestésicos, IP X8, sumergible  
 Interrupteur à pédale double, anti-explosif, catégorie AP, IP X8, immergeable  
 Interruttore a pedale doppio, anti-deflagrante, testato AP, IP X8, immergibile

**ME 400/200 (nur monopolar, monopolar only, sólo monopolar, monopolaire uniquement, solo monopolare)**  
**ME 401/411 (nur monopolar, monopolar only, sólo monopolar, monopolaire uniquement, solo monopolare)**  
**ME M1/ME MB 1**  
**ME CD1**  
**ME MB 3**  
**ME MB 2**  
**maXium®**



80-830-00-04

Doppelpedalfußschalter, 5 m Kabel, explosions-geschützt, AP-geprüft, IP X8, eintauchbar  
 Double-pedal foot switch, 5 m cable, explosion-proof, AP-tested, IP X8, immersible  
 Interruptor de pie de doble pedal, cable 5 m, antiexplosivo, controlada su aptitud para anestésicos, IP X8, sumergible  
 Interrupteur à pédale double, câble 5 m, anti-explosif, catégorie AP, IP X8, immergeable  
 Interruttore a pedale doppio, cavo 5 m, anti-deflagrante, testato AP, IP X8, immergibile

**ME 400/200 (nur monopolar, monopolar only, sólo monopolar, monopolaire uniquement, solo monopolare)**  
**ME 401/411 (nur monopolar, monopolar only, sólo monopolar, monopolaire uniquement, solo monopolare)**  
**ME M1/ME MB 1**  
**ME CD1**  
**ME MB 3**  
**ME MB 2**  
**maXium®**  
**maXium® smart C**



80-821-03-04

maXium®-SWAP-Mode-Doppelpedal-Fußschalter, explosionsgeschützt, AP-geprüft, IP X8, eintauchbar  
 maXium® double-pedal foot switch with SWAP mode, explosion-protected, AP-tested (anesthetics-proof), IP X8, immersible  
 Interruptor de pie de doble pedal maXium® con modo SWAP, protegido contra explosiones, controlada su aptitud para anestésicos, IP X8, sumergible  
 Interrupteur à double pédale maXium® avec mode SWAP, protégé contre les explosions, testé pour anesthésiants, IP X8, immergeable  
 Interruttore a doppio pedale maXium® con modalità SWAP, con protezione antiesplosione, a prova di anestetici, IP X8, immergibile

**maXium®**

**maXium® ab HW 06, Software V3.398**  
**maXium® from HW06 and software V3.398**  
**maXium® a partir del HW06 y software V3.398**  
**maXium® à partir de la version matérielle 06, version logicielle V3.398**  
**maXium® versione HW06 o superiore e software V3.398 o superiore**

Für alle Fußschalter gilt die Kabellänge 5 m  
 Cable length for all foot switches: 5 m  
 Todos los interruptores de pedal usan un cable de 5 m de longitud  
 La longueur de câble de 5 m est valable pour tous les interrupteurs à pédale  
 Il cavo lungo 5 m è indicato per tutti gli interruttori a pedale



#### 80-830-01-04

SWAP-Mode-Doppelpedalfußschalter, 5 m Kabel, explosionsgeschützt, AP-geprüft, IP X8, eintauchbar

SWAP mode double-pedal foot switch, 5 m cable, explosion-proof, AP-tested, IP X8, immersible

Interruptor de pie de doble pedal con modo SWAP, Interrupteur à pédale double avec mode SWAP, câble 5 m, anti-explosif, catégorie AP, IP X8, immergeable

Interruttore a pedale doppio con modo SWAP, cavo 5 m, anti-deflagrante, testato AP, IP X8, immergibile

**ME 400/200 (nur monopolar, monopolar only, sólo monopolar, monopolaire uniquement, solo monopolare)**

**ME 401/411 (nur monopolar, monopolar only, sólo monopolar, monopolaire uniquement, solo monopolare)**

**ME M1/ME MB 1**

**ME CD1**

**ME MB 3**

**ME MB 2**

**maXium®**

**maXium® smart C**

#### WIRELESS



#### 80-830-04-04

SWAP-Mode-Doppelpedalfußschalter, **kabellos**, explosionsgeschützt, AP-geprüft, IP X8, eintauchbar

SWAP mode double-pedal foot switch, **wireless**, explosion-proof, AP-tested, IP X8, immersible

Interruptor de pie de doble pedal con modo SWAP, **inalámbrico**, antiexplosivo, controlada su aptitud para anestésicos, IP X8, sumergible

Interrupteur à pédale double avec mode SWAP, **sans fil**, anti-explosif, catégorie AP, IP X8, immergeable

Interruttore a pedale doppio con modo SWAP, **senza fili**, anti-deflagrante, testato AP, IP X8, immergibile

**ME 400/200 (nur monopolar, monopolar only, sólo monopolar, monopolaire uniquement, solo monopolare)**

**ME 401/411 (nur monopolar, monopolar only, sólo monopolar, monopolaire uniquement, solo monopolare)**

**ME M1/ME MB 1**

**ME CD1**

**ME MB 3**

**ME MB 2**

**maXium®**

**maXium® smart C**

#### 80-830-05-04

Netzteil für 80-830-04-04 (muss separat bestellt werden)

Power supply unit for 80-830-04-04 (must be ordered separately)

Fuente de alimentación para 80-830-04-04 (se debe encargar por separado)

Bloc d'alimentation pour 80-830-04-04 (doit être commandé séparément)

Alimentatore per 80-830-04-04 (da ordinare separatamente)



#### 80-821-05-04

Doppelpedal-Fußschalter, explosionsgeschützt, AP-geprüft, IP X8, eintauchbar

Double-pedal foot switch, explosion- and anesthetics-proof (AP-tested), IP X8, immersible

Interruptor de pie de doble pedal, antiexplosivo, controlada su aptitud para anestésicos, IP X8, sumergible

Interrupteur à pédale double, anti-explosif, catégorie AP, IP X8, immergeable

Interruttore a pedale doppio, anti-deflagrante, testato AP, IP X8, immergibile

**ME 400/200 (nur monopolar, monopolar only, sólo monopolar, monopolaire uniquement, solo monopolare)**

**ME 401/411 (nur monopolar, monopolar only, sólo monopolar, monopolaire uniquement, solo monopolare)**

**ME M1/ME MB 1**

**ME CD1**

**ME MB 3**

**ME MB 2**

**maXium®**

**maXium® smart C**



80-811-30-04

Doppelpedal-Fußschalter, explosionsgeschützt, AP-geprüft, IP X8, eintauchbar  
 Double-pedal foot switch, explosion- and anesthetics-proof (AP-tested), IP X8, immersible  
 Interruptor de pie de doble pedal, antiexplosivo, controlada su aptitud para anestésicos, IP X8, sumergible  
 Interrupteur à pédale double, anti-explosif, catégorie AP, IP X8, immergeable  
 Interruttore a pedale doppio, anti-deflagrante, testato AP, IP X8, immergibile

**ME 400/200 (nur bipolar, bipolar only, sólo bipolar, monopolaire uniquement, solo bipolare)**  
**ME 401/411 (nur monopolar, monopolar only, sólo monopolar, monopolaire uniquement, solo monopolare)**  
**ME M1/ME MB 1**  
**ME CD1**  
**ME MB 3**  
**ME MB 2**  
**maXium®**  
**maXium® smart C**



80-811-32-04

maXium®-SWAP-Mode-Doppelpedal-Fußschalter Eco, AP-geprüft, IP X8, eintauchbar  
 maXium® double-pedal foot switch with SWAP mode Eco, AP-tested (anesthetics-proof), IP X8, immersible  
 Interruptor de pie de doble pedal maXium® con modo SWAP Eco, controlada su aptitud para anestésicos, IP X8, sumergible  
 Interrupteur à double pédale maXium® avec mode SWAP Eco, testé pour anesthésiants, IP X8, immergeable  
 Interruttore a doppio pedale maXium® con modalità SWAP Eco, a prova di anestetici, IP X8, immergibile

**maXium®**  
**maXium® ab HW 06, Software V3.398**  
**maXium® from HW06 and software V3.398**  
**maXium® a partir del HW06 y software V3.398**  
**maXium® à partir de la version matérielle 06, version logicielle V3.398**  
**maXium® versione HW06 o superiore e software V3.398 o superiore**  
**maXium® smart C**



80-811-04-04

Fußschalter, explosionsgeschützt, AP-geprüft, IP X8, eintauchbar  
 Foot switch, explosion- and anesthetics-proof (AP-tested), IP X8, immersible  
 Interruptor de pie, antiexplosivo, controlada su aptitud para anestésicos, IP X8, eintauchbar  
 Interrupteur à pédale, anti-explosif, catégorie AP, IP X8, immergeable  
 Interruttore a pedale, anti-deflagrante, testato AP, IP X8, immergibile

**ME 200/400 (nur bipolar, bipolar only, sólo bipolar, bipolaire uniquement, solo bipolare)**  
**ME 401/411 (nur bipolar, bipolar only, sólo bipolar, bipolaire uniquement, solo bipolare)**  
**maXium®**

Für alle Fußschalter gilt die Kabellänge 5 m  
 Cable length for all foot switches: 5 m  
 Todos los interruptores de pedal usan un cable de 5 m de longitud  
 La longueur de câble de 5 m est valable pour tous les interrupteurs à pédale  
 Il cavo lungo 5 m è indicato per tutti gli interruttori a pedale



80-830-02-04

Einpedalfußschalter, 5 m Kabel, explosionsgeschützt, AP-geprüft, IP X8, eintauchbar

Single-pedal foot switch, 5 m cable, explosion-proof, AP-tested, IP X8, immersible

Interruptor de pie de un pedal, Interrupteur à une pédale câble 5 m, anti-explosif, catégorie AP, IP X8, immergeable

Interruttore monopedale, cavo 5 m, anti-deflagrante, testato AP, IP X8, immergibile

**ME 200/400 (nur bipolar, bipolar only, sólo bipolar, bipolaire uniquement, solo bipolare)**  
**ME 401/411 (nur bipolar, bipolar only, sólo bipolar, bipolaire uniquement, solo bipolare)**  
**maXium®**  
**maXium® smart C**



80-821-04-04

Bipolarer Doppelpedal-Fußschalter, explosionsgeschützt, AP-geprüft, IP X8, immersible

Bipolar double-pedal switch, explosion- and anesthetics-proof (AP-tested), IP X8, eintauchbar

Interruptor de pedal doble, bipolar, antiexplosivo, controlada su aptitud para anestésicos, IP X8, sumergible

Interrupteur à pédale double, bipolaire, anti-explosif, catégorie AP, IP X8, immergeable

Interruttore a doppio pedale, anti-deflagrante, testato AP, IP X8, immergibile

**ME 401/411**



80-811-50-04

Fußschalter, explosionsgeschützt, AP-geprüft, IP X8, immersible

Foot switch, explosion- and anesthetics-proof (AP-tested), IP X8, eintauchbar

Interruptor de pie, antiexplosivo, controlada su aptitud para anestésicos, IP X8, sumergible

Interrupteur à pédale, anti-explosif, catégorie AP, IP X8, immergeable

Interruttore a pedale, anti-deflagrante, testato AP, IP X8, immergibile

**ME 200/400 (nur bipolar, bipolar only, sólo bipolar, bipolaire uniquement, solo bipolare)**  
**ME 401/411 (nur bipolar, bipolar only, sólo bipolar, bipolaire uniquement, solo bipolare)**  
**maXium®**  
**maXium® smart C**



80-825-30-04

Bipolarer Doppelpedal-Fußschalter,  
explosionsgeschützt, AP-geprüft, IP X8, eintauchbar

Bipolar double-pedal switch, explosion-  
and anesthetics-proof (AP-tested), IP X8, immersible

Interruptor de pedal doble, bipolar, antiexplosivo,  
controlada su aptitud para anestésicos,  
IP X8, sumergible

Interrupteur à pédale double, bipolaire,  
anti-explosif, catégorie AP, IP X8, immergeable

Interruttore a doppio pedale, anti-deflagrante,  
testato AP, IP X8, immergibile

**ME 401/411**



80-797-00-04

Adapter mit gewinkeltem Stecker

Adapter with angled connector

Adaptador con clavija acodada

Adaptateur avec connecteur coudé

Adattatore con connettore angolato

**für Fußschalter  
for foot switch  
para interruptor de pedal  
pour interrupteur à pédale  
per interruttore a pedale**

**80-821-02-04**

**80-821-03-04**

**80-811-30-04**

**80-811-32-04**

**80-821-05-04**

1/3



80-797-01-04

Adapter mit gewinkeltem Stecker

Adapter with angled connector

Adaptador con clavija acodada

Adaptateur avec connecteur coudé

Adattatore con connettore angolato

**für Fußschalter  
for foot switch  
para interruptor de pedal  
pour interrupteur à pédale  
per interruttore a pedale**

**80-811-04-04**

**80-811-50-04**

1/3

Für alle Fußschalter gilt die Kabellänge 5 m

Cable length for all foot switches: 5 m





Todos los interruptores de pedal usan un cable de 5 m de longitud









La longueur de câble de 5 m est valable pour tous les interrupteurs à pédale

Il cavo lungo 5 m è indicato per tutti gli interruttori a pedale









Fußschalter Foot switches Interruptores de pie Interrupteurs à pédale Interruttori a pedale	KLS Martin Kleingeräte / Low-end units / Equipos de gama baja / Petits appareils / Apparecchi di piccole dimensioni						
	ME 81	ME 82	miniCutter	ME 102	ME K1	ME K2	MD 62
<b>80-811-50-04</b> 	<b>X</b> nur bipolar, bipolar only, sólo bipolar, bipolaire uniquement, solo bipolare	<b>X</b>	<b>X</b>	<b>X</b> nur bipolar, bipolar only, sólo bipolar, bipolaire uniquement, solo bipolare	<b>X</b>	<b>X</b>	
<b>80-811-04-04</b> 	<b>X</b> nur bipolar, bipolar only, sólo bipolar, bipolaire uniquement, solo bipolare	<b>X</b>	<b>X</b>	<b>X</b> nur bipolar, bipolar only, sólo bipolar, bipolaire uniquement, solo bipolare			
<b>80-824-01-04</b> 	<b>X</b> nur monopolar, monopolar only, sólo monopolar, monopolaire uniquement, solo monopolare	<b>X</b> nur monopolar, monopolar only, sólo monopolar, monopolaire uniquement, solo monopolare		<b>X</b> nur monopolar, monopolar only, sólo monopolar, monopolaire uniquement, solo monopolare			
<b>80-812-10-04</b> 							<b>X</b>
<b>80-823-02-04</b>  <b>NON-CE</b>	<b>X</b> nur monopolar, monopolar only, sólo monopolar, monopolaire uniquement, solo monopolare			<b>X</b> nur monopolar, monopolar only, sólo monopolar, monopolaire uniquement, solo monopolare			

Fußschalter Foot switches Interruptores de pie Interrupteurs à pédale Interruttori a pedale	KLS Martin Großgeräte / High-end units / Equipos de gama alta / Grands appareils / Apparecchi di grandi dimension										
	maXium®	maXium® smart C	ME 411	ME 401	ME 400	ME 200	ME MB 1	ME M1	ME CD1	ME MB 2	ME MB 3
80-821-02-04 	X	X	X nur monopolar, monopolar only, sólo monopolar, monopolaire uniquement, solo monopolare	X nur monopolar, monopolar only, sólo monopolar, monopolaire uniquement, solo monopolare	X nur monopolar, monopolar only, sólo monopolar, monopolaire uniquement, solo monopolare	X nur monopolar, monopolar only, sólo monopolar, monopolaire uniquement, solo monopolare	X	X	X	X	X
80-821-03-04 	X nur ab only from sólo a partir de uniquement solo HW. 06, SW V3.398	X									
80-811-32-04 	X nur ab only from sólo a partir de uniquement solo HW. 06, SW V3.398	X									
80-821-05-04 	X	X	X nur monopolar, monopolar only, sólo monopolar, monopolaire uniquement, solo monopolare	X nur monopolar, monopolar only, sólo monopolar, monopolaire uniquement, solo monopolare	X nur monopolar, monopolar only, sólo monopolar, monopolaire uniquement, solo monopolare	X nur monopolar, monopolar only, sólo monopolar, monopolaire uniquement, solo monopolare	X	X	X	X	X
80-821-04-04 			X nur bipolar, bipolar only, sólo bipolar, bipolaire uniquement, solo bipolare	X							
80-811-30-04 	X	X	X nur monopolar, monopolar only, sólo monopolar, monopolaire uniquement, solo monopolare	X nur monopolar, monopolar only, sólo monopolar, monopolaire uniquement, solo monopolare	X nur monopolar, monopolar only, sólo monopolar, monopolaire uniquement, solo monopolare	X nur monopolar, monopolar only, sólo monopolar, monopolaire uniquement, solo monopolare	X	X	X	X	X
80-825-30-04 			X nur bipolar, bipolar only, sólo bipolar, bipolaire uniquement, solo bipolare	X							
80-811-04-04 	X	X	X nur bipolar, bipolar only, sólo bipolar, bipolaire uniquement, solo bipolare	X nur bipolar, bipolar only, sólo bipolar, bipolaire uniquement, solo bipolare	X nur bipolar, bipolar only, sólo bipolar, bipolaire uniquement, solo bipolare	X nur bipolar, bipolar only, sólo bipolar, bipolaire uniquement, solo bipolare					
80-811-50-04 	X	X	X nur bipolar, bipolar only, sólo bipolar, bipolaire uniquement, solo bipolare	X nur bipolar, bipolar only, sólo bipolar, bipolaire uniquement, solo bipolare	X nur bipolar, bipolar only, sólo bipolar, bipolaire uniquement, solo bipolare	X nur bipolar, bipolar only, sólo bipolar, bipolaire uniquement, solo bipolare					



Fußschalter Foot switches Interruptores de pie Interrupteurs à pédale Interruttori a pedale	KLS Martin Großgeräte / High-end units / Equipos de gama alta / Grands appareils / Apparecchi di grandi dimension										
	maXium®	maXium® smart C	ME 411	ME 401	ME 400	ME 200	ME MB 1	ME M1	ME CD1	ME MB 2	ME MB 3
80-830-00-04 	X	X	X nur monopolar, monopolar only, sólo monopolar, monopolaire uniquement, solo monopolare	X nur monopolar, monopolar only, sólo monopolar, monopolaire uniquement, solo monopolare	X nur monopolar, monopolar only, sólo monopolar, monopolaire uniquement, solo monopolare	X nur monopolar, monopolar only, sólo monopolar, monopolaire uniquement, solo monopolare	X	X	X	X	X
80-830-01-04 	X nur ab only from sólo a partir de uniquement solo HW. 06, SW V3.398	X									
80-830-04-04 + 80-830-05-04 	X nur ab only from sólo a partir de uniquement solo HW. 06, SW V3.398	X									
80-830-02-04 	X	X	X	X	X	X					

Netzkabel  
Mains cables  
Cables de conexión a la red  
Câbles d'alimentation réseau  
Cavi d'alimentazione dalla rete

# 11

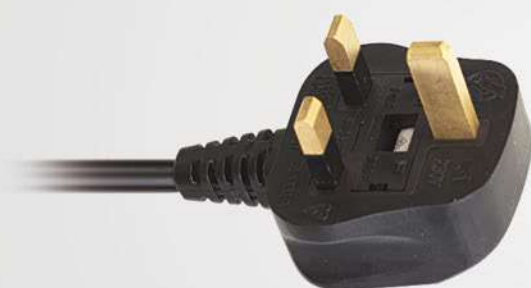

Netzkabel  
 Mains cables  
 Cables de conexión a la red  
 Câbles d'alimentation réseau  
 Cavi d'alimentazione dalla rete



1/3

08-024-00-23

3 m

Netzkabel, z.B. für Deutschland, Frankreich, Österreich, Skandinavien, Korea

Mains cables, for ex. for Germany, France, Austria, Scandinavia, Korea

Cables de conexión a la red, p. ej. para Alemania, Francia, Austria, Escandinavia, Corea

Câbles d'alimentation réseau, par ex. pour l'Allemagne, France, Autriche, Scandinavie, la Corée

Cavi d'alimentazione, p. es. per la Germania, Francia, Austria, Scandinavia, Corea



1/3

08-025-00-23

5 m

Netzkabel, z.B. für Deutschland, Frankreich, Österreich, Skandinavien, Korea

Mains cables, for ex. for Germany, France, Austria, Scandinavia, Korea

Cables de conexión a la red, p. ej. para Alemania, Francia, Austria, Escandinavia, Corea

Câbles d'alimentation réseau, par ex. pour l'Allemagne, France, Autriche, Scandinavie, la Corée

Cavi d'alimentazione, p. es. per la Germania, Francia, Austria, Scandinavia, Corea



1/3

08-024-00-30

2,5 m

Netzkabel für Italien

Mains cables for Italy

Cables de conexión a la red para Italia

Câbles d'alimentation réseau pour l'Italie

Cavi d'alimentazione per Italia



1/3

08-024-00-40

1,8 m

Netzkabel für Grossbritannien, Irland, Vereinigte Arabische Emirate

Mains cables for United Kingdom, Ireland, United Arab Emirates

Cables de red para el Reino Unido, Irlanda, Emiratos Árabes Unidos.

Câbles d'alimentation réseau pour la Grande-Bretagne, l'Irlande, les Emirats Arabes Unis

Cavi di rete per Gran Bretagna, Irlanda, Emirati Arabi Uniti



1/3

08-024-00-83

5 m

Netzkabel für Grossbritannien, Irland, Vereinigte Arabische Emirate

Mains cables for United Kingdom, Ireland, United Arab Emirates

Cables de red para el Reino Unido, Irlanda, Emiratos Árabes Unidos.

Câbles d'alimentation réseau pour la Grande-Bretagne, l'Irlande, les Emirats Arabes Unis

Cavi di rete per Gran Bretagna, Irlanda, Emirati Arabi Uniti



1/3

08-024-00-31

2,5 m

Netzkabel für Japan

Mains cables for Japan

Cables de conexión a la red para Japón

Câbles d'alimentation réseau pour Japon

Cavi d'alimentazione per Giappone

08-024-00-85

5 m



1/3

08-024-00-28

1,8 m

Netzkabel, z.B. für Taiwan, USA, Kanada

Mains cables, for ex. for Taiwan, USA, Canada

Cables de conexión a la red, p. ej. para Taiwan, USA, Canadá

Câbles d'alimentation réseau, par ex. pour Taiwan, USA, Canada

Cavi d'alimentazione, p. es. per Taiwan, USA, Canada



1/3

08-024-00-29

2 m

Netzkabel, z.B. für Taiwan, USA, Kanada

Mains cables, for ex. for Taiwan, USA, Canada

Cables de conexión a la red, p. ej. para Taiwan, USA, Canadá

Câbles d'alimentation réseau, par ex. pour Taiwan, USA, Canada

Cavi d'alimentazione, p. es. per Taiwan, USA, Canada



1/3

08-024-00-41

2,5 m

Netzkabel für China

Mains cables for China

Cables de conexión a la red para China

Câbles d'alimentation réseau pour Chine

Cavi d'alimentazione per Cina

Fahrgestelle  
Trolleys  
Soportes móviles  
Chariots  
Carrelli

# 12



Fahrgestelle/maXium® smart Cart  
 Trolleys/maXium® smart Cart  
 Soportes móviles/maXium® smart Cart  
 Supports roulants (chariots)/maXium® smart Cart  
 Carrelli/maXium® smart Cart



Konfiguration mit maXium®,  
 maXium® beamer und maXium® smart Vac  
 Configuration with maXium®, maXium® beamer  
 and maXium® smart Vac  
 Configuración con maXium®, maXium® beamer  
 y maXium® smart Vac  
 Configuration avec maXium®, maXium® beamer  
 et maXium® smart Vac  
 Configurazione con maXium®, maXium® beamer  
 e maXium® smart Vac

<b>80-048-00-04</b> <b>maXium® smart Cart –</b> <b>geeignet für alle KLS-Martin-Großgeräte</b>	<b>80-048-00-04</b> <b>maXium® smart Cart –</b> <b>suitable for all major KLS Martin units</b>	<b>80-048-00-04</b> <b>maXium® smart Cart – adecuado para todos</b> <b>los aparatos de gran tamaño de KLS Martin</b>
Abmessungen (B x H x T): 755 x 1080 x 655 mm	Dimensions (W x H x D): 755 x 1080 x 655 mm	Dimensiones (An + Al + P): 755 x 1080 x 655 mm
4 Doppelrollen mit 2 Bremsen	4 dual castors with 2 brakes	4 ruedas dobles con 2 frenos
Ablagekorb	Storage basket	Bandeja
Potenzialausgleichsanschlüsse (POAG)	Equipotential bonding connections (POAG)	Conexiones equipotenciales (POAG)
Fußschalterhalterung	Foot switch holder	Soporte para pedal
Netzkabel 5 m	Mains cable 5 m	Cable de red 5 m
Netzabgänge	Mains power outputs	Salidas de red
Gewicht 40 Kg	Weight 40 kg	Peso 40 kg
<b>Geräteaufnahme</b> (muss zwingend notwendig mitbestellt werden)	<b>Device holder</b> (must be included in the order)	<b>Soporte de aparato</b> (es imprescindible encargarlo)
80-048-03-04 Geräteaufnahme für maXium® smart Line	Device holder for maXium® smart Line	Soporte de aparato para maXium® smart Line
80-048-04-04 Aufnahme für maXium® White Edition	Holder for maXium® White Edition	Soporte para maXium® White Edition
<b>Optionales Zubehör:</b>	<b>Optional accessories:</b>	<b>Accesorios opcionales:</b>
80-048-01-04 Normschiene	Standard rail	Riel normalizado
80-048-02-04 Trenntransformator	Separating transformer	Transformador de aislamiento
80-048-05-04 Gasflaschenhalter	Gas bottle holder	Soporte para cilindros de gas
80-048-06-04 Befestigungssatz für maXium® smart Vac®	Mounting kit for maXium® smart Vac®	Kit de fijación para maXium® smart Vac®
08-031-10-04 Adapterkabel für Funkfußschalter	Adapter cable for wireless foot switch	Cable adaptador para interruptor de pedal inalámbrico

Die abgebildeten Geräte sind im Lieferumfang nicht enthalten!  
 The HF units shown are not included in the scope of supply!  
 ¡Los equipos representados en las imágenes no forman parte del suministro!  
 Les appareils présentés ici ne font pas partie de la livraison !  
 Gli apparecchi raffigurati non fanno parte della fornitura!



Konfiguration mit maXium® smart C,  
maXium® smart Beam und maXium® smart Vac  
Configuration with maXium® smart C,  
maXium® smart Beam and maXium® smart Vac  
Configuración con maXium® smart C,  
maXium® smart Beam y maXium® smart Vac  
Configuration avec maXium® smart C,  
maXium® smart Beam et maXium® smart Vac  
Configurazione con maXium® smart C,  
maXium® smart Beam e maXium® smart Vac



80-260-50-04

4 m

Potenzialausgleichskabel  
Potential equalization cable  
Cable de conexión equipotencial  
Câble de compensation de potentiel  
Cavo per collegamento equipotenziale

<p><b>80-048-00-04</b> <b>maXium® smart Cart –</b> <b>pour tous les grands appareils KLS Martin</b></p> <p>Dimensions (l x H x p) : 755 x 1080 x 655 mm 4 roulettes doubles avec 2 freins Panier de rangement Raccords d'équipotentialité (POAG) Support d'interrupteur à pédale Câble secteur 5 m Prises d'alimentation Poids 40 kg</p>	<p><b>80-048-00-04</b> <b>maXium® smart Cart –</b> <b>indicato per tutti i grandi apparecchi KLS Martin</b></p> <p>Dimensioni (L x A x P): 755 x 1080 x 655 mm 4 ruote doppie con 2 freni Cestello portaoggetti Attacchi per collegamento equipotenziale (POAG) Supporto interruttore a pedale Cavo di rete 5 m Uscite di rete Peso 40 kg</p>
<p><b>Logement</b> (doit impérativement être commandé)</p> <p>80-048-03-04 Logement pour maXium® smart Line 80-048-04-04 Logement pour maXium® White Edition</p>	<p><b>Supporto apparecchio</b> (da ordinarsi obbligatoriamente assieme all'apparecchio)</p> <p>Supporto apparecchio per maXium® smart Line Supporto per maXium® White Edition</p>
<p><b>Accessoires facultatifs :</b></p> <p>80-048-01-04 Rail standard 80-048-02-04 Transformateur d'isolement 80-048-05-04 Porte-bouteille 80-048-06-04 Set de fixation pour maXium® smart Vac® 08-031-10-04 Câble d'adaptateur pour interrupteur à pédale radio</p>	<p><b>Accessori opzionali:</b></p> <p>Guida normata Trasformatore di isolamento Supporto bombola gas Set di fissaggio per maXium® smart Vac® Cavo adattatore per radiointerruttore pedale</p>

Die abgebildeten Geräte sind im Lieferumfang nicht enthalten!  
The HF units shown are not included in the scope of supply!  
¡Los equipos representados en las imágenes no forman parte del suministro!  
Les appareils présentés ici ne font pas partie de la livraison !  
Gli apparecchi raffigurati non fanno parte della fornitura!



maXium® smart Cart mit verschiedenen Komponenten  
maXium® smart Cart with various components  
maXium® smart Cart con diferentes componentes  
maXium® smart Cart avec différents composants  
maXium® smart Cart con diversi componenti

**Frontansicht maXium® smart Cart (Art.-Nr. 80-048-00-04)**  
**Front view of maXium® smart Cart (item no. 80-048-00-04)**  
**Vista frontal del maXium® smart Cart (n.º ref. 80-048-00-04)**  
**Vue de face de maXium® smart Cart (réf. 80-048-00-04)**  
**Immagine frontale di maXium® smart Cart (codice art. 80-048-00-04)**

Netzkabel, 5 m, z.B. für Deutschland,  
Frankreich, Österreich, Skandinavien  
Mains cables, 5 m, for ex. for Germany,  
France, Austria, Scandinavia  
Cables de conexión a la red, 5 m, p. ej.  
para Alemania, Francia, Austria, Escandinavia  
Câbles d'alimentation réseau, 5 m, par ex.  
pour l'Allemagne, France, Autriche, Scandinavie  
Cavi d'alimentazione, 5 m, p. es. per la  
Germania, Francia, Austria, Scandinavia

Gasflaschenhalter für 2 Gasflaschen  
Gas bottle holder for 2 gas bottles  
Soporte para cilindros de gas  
para 2 cilindros de gas  
Porte-bouteille de gaz  
pour 2 porte-bouteilles de gaz  
Supporto bombola gas  
per 2 bombole gas

Doppelenk-Rolle mit Bremse (2 Stück)  
Dual castor with brake (2 items)  
Rodillo doble giratorio con freno (2 unidades)  
Roulette double avec frein de blocage (2 pièces)  
Rotelle orientabili doppie con freno (2 pezzi)



Die abgebildeten Geräte sind im Lieferumfang nicht enthalten!  
The HF units shown are not included in the scope of supply!  
¡Los equipos representados en las imágenes no forman parte del suministro!  
Les appareils présentés ici ne font pas partie de la livraison !  
Gli apparecchi raffigurati non fanno parte della fornitura!



**Rückansicht maXium® smart Cart (Art.-Nr. 80-048-00-04)**  
**Rear view of maXium® smart Cart (item no. 80-048-00-04)**  
**Vista posterior del maXium® smart Cart (n.º ref. 80-048-00-04)**  
**Vue de derrière de maXium® smart Cart (réf. 80-048-00-04)**  
**Immagine posteriore di maXium® smart Cart (codice art. 80-048-00-04)**

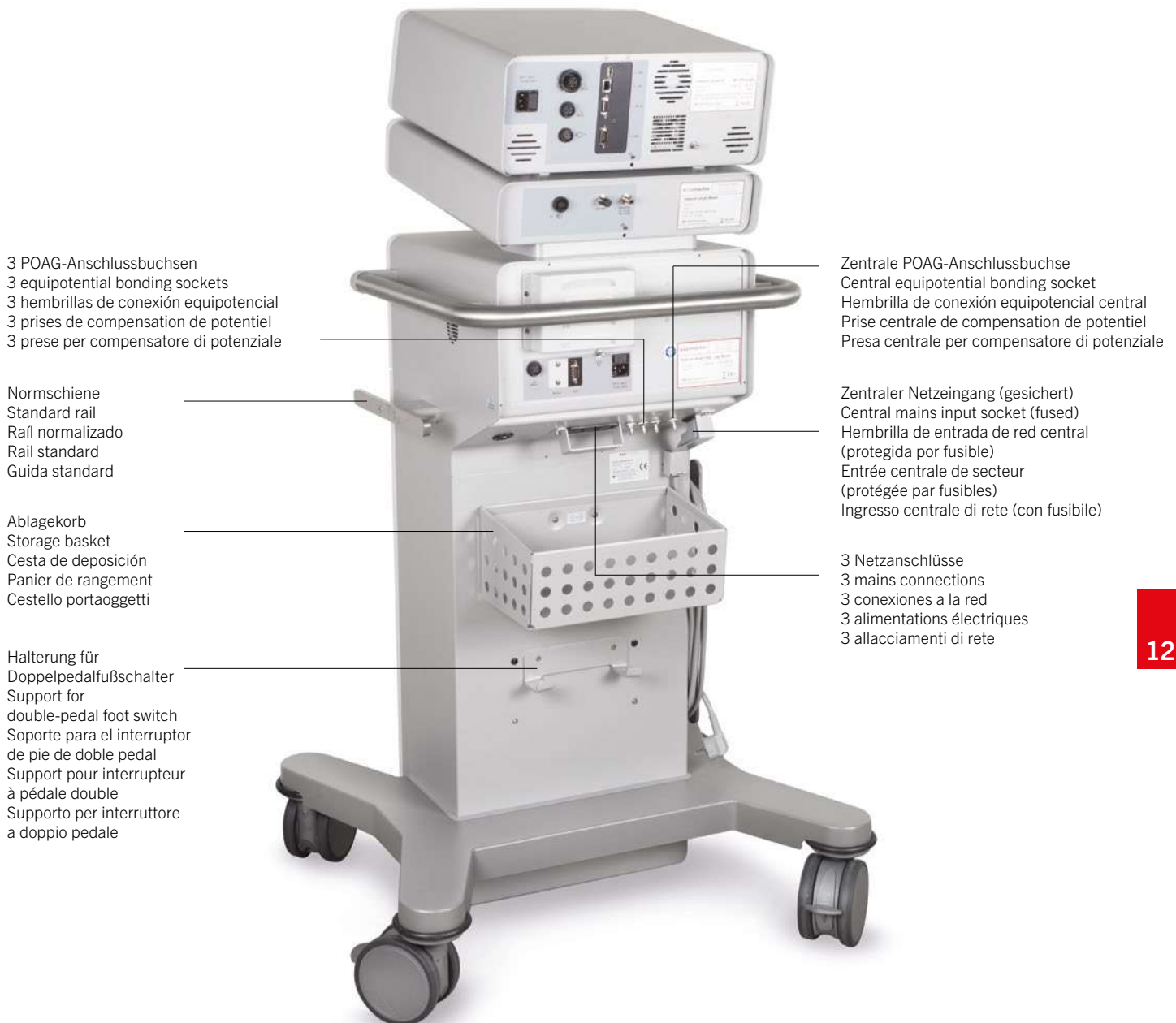

3 POAG-Anschlussbuchsen  
3 equipotential bonding sockets  
3 hembrillas de conexión equipotencial  
3 prises de compensation de potentiel  
3 prese per compensatore di potenziale

Normschiene  
Standard rail  
Raíl normalizado  
Rail standard  
Guida standard

Ablagekorb  
Storage basket  
Cesta de deposición  
Panier de rangement  
Cestello portaoggetti

Halterung für  
Doppelpedalfußschalter  
Support for  
double-pedal foot switch  
Soporte para el interruptor  
de pie de doble pedal  
Support pour interrupteur  
à pédale double  
Supporto per interruttore  
a doppio pedale

Zentrale POAG-Anschlussbuchse  
Central equipotential bonding socket  
Hembrilla de conexión equipotencial central  
Prise centrale de compensation de potentiel  
Presa centrale per compensatore di potenziale

Zentraler Netzeingang (gesichert)  
Central mains input socket (fused)  
Hembrilla de entrada de red central  
(protegida por fusible)  
Entrée centrale de secteur  
(protégée par fusibles)  
Ingresso centrale di rete (con fusibile)

3 Netzanschlüsse  
3 mains connections  
3 conexiones a la red  
3 alimentations électriques  
3 allacciamenti di rete



80-070-00-04

HF-Fahrwagen  
 HF trolley  
 Carro portaequipos de AF  
 Chariot HF  
 Carrello AF

für maXium® smart C bitte zusätzlich Halterung 80-070-06-04 bestellen  
 for maXium® smart C please also order holder 80-070-06-04  
 encargar para maXium® smart C adicionalmente el soporte 80-070-06-04  
 pour maXium® smart C, prière de commander en supplément le support 80-070-06-04  
 per maXium® smart C si prega di ordinare anche il supporto 80-070-06-04

	Befestigungssatz	Fastening kit	Juego de sujeción	Set d'accrochage	Set di fissaggio
80-070-02-04	für ME 102	for ME 102	para ME 102	pour ME 102	per ME 102
80-070-03-04	für miniCutter	for miniCutter	para miniCutter	pour miniCutter	per miniCutter
80-070-04-04	für MD 62	for MD 62	para MD 62	pour MD 62	per MD 62
80-070-06-04	für maXium® smart Line	for maXium® smart Line	para maXium® smart Line	pour maXium® smart Line	per maXium® smart Line

- Geeignet für alle KLS-Martin-HF-Großgeräte, z.B. ME MB 1, ME MB 3, maXium®, maXium® smart C
- Farbe: Eloxal-Silber
- Elektrisch leitfähige Doppelrollen (ESD) mit 65 mm Durchmesser
- Ablagefach
- Kabelhalterung für das Netzkabel
- Abmessungen: 400 x 430 x 900 mm (B x H x T)
- Gewicht: 12 Kg

- Pour tous les grands appareils HF KLS Martin, par ex. ME MB 1, ME MB 3 maXium®, maXium® smart C
- Couleur: anodisation argentée
- Roues doubles conductrices (ESD) de diamètre 65 mm
- Compartiment de rangement
- Attache pour le câble de réseau
- Dimensions: 400 x 430 x 900 mm (l x h x p)
- Poids: 12 Kg

- Suitable for all major KLS Martin HF units. e.g. ME MB 1, ME MB 3, maXium®, maXium® smart C
- Color: silver-anodized
- Electrically conductive dual castors (ESD), diameter 65 mm
- Storage compartment
- Power cord holder
- Dimensions: 400 x 430 x 900 mm (W x H x D)
- Weight: 12 Kg

- Adatto a tutti gli apparecchi grandi AF KLS Martin, p. es. ME MB 1, ME MB 3 maXium®, maXium® smart C
- Colore: anodizzazione argentea
- Rotelle doppie (ESD) a conduzione elettrica con diametro di 65 mm
- Compartimento
- Supporto cavo per cavo di alimentazione
- Dimensioni: 400 x 430 x 900 mm (L x A x P)
- Peso: 12 Kg

- Adecuado para todos los equipos de AF KLS Martin de gran tamaño, p. ej. ME MB 1, ME MB 3, maXium®, maXium® smart C
- Color: anodizado plateado
- Rodillos dobles electroconductores (DES) con 65 mm de diámetro
- Cajón de deposición
- Sujeción para el cable de red
- Dimensiones: 400 x 430 x 900 mm (An x A x P)
- Peso: 12 Kg



**Optionales Zubehör für HF-Fahrgewagen Art.-Nr. 80-070-00-04**  
**Optional accessories for HF trolley no. 80-070-00-04**  
**Accesorio opcional para el carro de AF, n.º ref. 80-070-00-04**  
**Accessoires en option pour chariot HF, réf. 80-070-00-04**  
**Accessori opzionali per carrello AF, codice art. 80-070-00-04**



80-070-01-04

Halterung für Argon-Gasflasche  
Support for argon gas cylinder  
Soporte para la sujeción de la bombona de gas argón  
Support pour bouteille de gaz d'argon  
Supporto per bombola di gas argon

08-156-00-11

Rolle, feststellbar, für HF-Fahrgewagen (1 Stück)  
Castor, lockable, for HF trolley (1 piece)  
Rodillo, bloqueable, para carro de AF (1 pieza)  
Roulette, blocable, pour chariot HF (1 pièce)  
Rotella, bloccabile, per carrello AF (1 pezzo)

80-070-05-04

Rollensatz für HF-Fahrgewagen 80-070-00-04  
Ø 100 mm (2 Stück feststellbar, 2 Stück ungebremst)  
Set of castors for HF trolley 80-070-00-04,  
Ø 100 mm (2 lockable, 2 without brake)  
Juego de ruedas para el carro portaequipos 80-070-00-04,  
Ø 100 mm (2 unidades bloqueables, 2 unidades sin freno)  
Lot de roulettes pour chariot HF 80-070-00-04  
Ø 100 mm (2 roulettes blocables, 2 roulettes non freinées)  
Set di rotelle per carrello AF 80-070-00-04, Ø 100 mm  
(2 rotelle fissabili, 2 rotelle senza freno)

Zubehörsätze  
Accessory sets  
Juegos de accesorios  
Jeux d'accessoires  
Serie di accessori

# 13

## Zubehörsätze für Großgeräte

Accessory sets for major electrosurgical units

Juegos de accesorios para gran aparatos

Jeux d'accessoires pour grands appareils

Serie di accessori per apparecchi grandi

80-140-00-04	Großer Zubehörsatz monopolar, Handaktivierung für ME MB 3/ ME MB 1/ maxium („m“-Version), bestehend aus:	Accessory set monopolar, large for hand switch operation ME MB 3/ ME MB 1/ maXium® („m“-version), consisting of:	Juego de accesorios monopolar, grande con interruptor digital ME MB 3/ ME MB 1/ maXium® (versión "m"), compuesto de:
80-217-13-04	1 smartPen Elektroden-Handgriff mit zwei Tasten für 4-mm-Elektroden, mit KLS Martin-Stecker	- smartPen Elektroden-Handgriff mit zwei Tasten für 4-mm-Elektroden, mit KLS Martin-Stecker	- smartPen Elektroden-Handgriff mit zwei Tasten für 4-mm-Elektroden, mit KLS Martin-Stecker
80-342-03-04	1 Gummi-Neutralelektrode 15 x 26 cm, 4 m Kabel	- Rubber neutral electrode, 15 x 26 cm, with connection cable, 4 m	- Placa neutra de goma, 15 x 26 cm, cable de conexión de 4 m
80-371-00-04	2 Gummibinden, gelocht, 100 cm	- Rubber bands, with holes, 100 cm	- Cintas de goma, perforadas, 100 cm
80-371-01-04	2 Knöpfe für Gummibinde	- Buttons for rubber band	- Botones para la cinta de goma
80-416-00-01	1 Elektroden-Ständer für 16 Elektroden	- Electrode box for 16 electrodes	- Caja para 16 electrodos
80-505-00-04	1 Reinigungspad für Elektroden, steril verpackt, VE = 100 Stck.	- Cleaning pad for electrodes, sterile packed, SU = 100/pack	- Almohadilla de limpieza para electrodos, embalado estéril, UV = 100 piezas
80-510-04-04	1 Lanzettelektrode, gerade	- Lancet electrode, straight	- Electrodo de lanceta, recto
80-511-04-04	1 Lanzettelektrode, abgewinkelt	- Lancet electrode, angled	- Electrodo de lanceta, acodado
80-515-04-04	1 Messerelektrode	- Knife electrode	- Electrodo de cuchillo
80-520-04-04	1 Nadelelektrode	- Needle electrode	- Electrodo de aguja
80-540-04-04	1 Drahtschlingenelektrode, Ø 5 mm	- Wire loop electrode, Ø 5 mm	- Electrodo de asa de alambre, Ø 5 mm
80-542-04-04	1 Drahtschlingenelektrode, Ø 10 mm	- Wire loop electrode, Ø 10 mm	- Electrodo de asa de alambre, Ø 10 mm
80-550-04-04	1 Bandschlingenelektrode, Ø 10 mm	- Ribbon loop electrode, Ø 10 mm	- Electrodo de asa de cinta, Ø 10 mm
80-552-04-04	1 Bandschlingenelektrode, Ø 15 mm	- Ribbon loop electrode, Ø 15 mm	- Electrodo de asa de cinta, Ø 15 mm
80-560-04-04	1 Kugelelektrode, Ø 2 mm	- Ball electrode, Ø 2 mm	- Electrodo de bola, Ø 2 mm
80-562-04-04	1 Kugelelektrode, Ø 4 mm	- Ball electrode, Ø 4 mm	- Electrodo de bola, Ø 4 mm
80-563-04-04	1 Kugelelektrode, Ø 5 mm	- Ball electrode, Ø 5 mm	- Electrodo de bola, Ø 5 mm
80-570-04-04	1 Plattenelektrode, 8 x 10 mm	- Plate electrode, 8 x 10 mm	- Electrodo de placa, 8 x 10 mm

80-150-00-04	Zubehörsatz bipolar für KLS Martin maxium („m“-Version), ME MB 3/ME MB 1*	Set bipolar accessories for KLS Martin maXium® („m“-Version), ME MB 3/ME MB 1*	Juego de accesorios bipolar para KLS Martin maXium® (versión "m"), ME MB 3/ME MB 1*
80-287-53-04	1 Anschlusskabel für bipolare Pinzetten	- Connection cable for bipolar forceps	- Cable de conexión para pinzas bipolares
80-924-16-04	1 Bipolare Pinzette, gerade, stumpf, 16 cm/6 1/4"	- Bipolar forceps, straight, blunt, 16 cm/6 1/4"	- Pinza bipolar, recta, roma, 16 cm/6 1/4"
80-945-20-04	1 Bipolare Pinzette, bajonettförmig, stumpf, 20 cm/8"	- Bipolar forceps, bayonet-shaped, blunt, 20 cm/8"	- Pinza bipolar, en forma bayoneta, roma, 20 cm/8"
80-925-16-04	1 Bipolare Pinzette, abgewinkelt, stumpf, 16 cm/6 1/4"	- Bipolar forceps, angled, blunt, 16 cm/6 1/4"	- Pinza bipolar, acodada, roma, 16 cm/6 1/4"

Zubehörsätze für Großgeräte  
 Accessory sets for major electrosurgery units  
 Juegos de accesorios para gran aparatos  
 Jeux d'accessoires pour grands appareils  
 Serie di accessori per apparecchi grandi

<b>80-140-00-04</b>		<b>Großer Zubehörsatz monopolar, Handaktivierung für ME MB 3/ ME MB 1/ maXium® m, bestehend aus:</b>	<b>Accessory set monopolar, large for hand switch operation ME MB 3/ ME MB 1/ maXium® m, consisting of:</b>	<b>Juego de accesorios monopolar, grande con interruptor digital ME MB 3/ ME MB 1/ maXium® m, compuesto de:</b>
80-217-13-04	1	smartPen Elektroden-Handgriff mit zwei Tasten für 4-mm-Elektroden, mit KLS Martin-Stecker	smartPen Electrode handle with two pushbuttons for 4-mm electrodes, with KLS Martin plug	Mango porta-electrodos smartPen con dos teclas, para electrodos de 4 mm, con clavija de KLS Martin
80-342-03-04	1	Gummi-Neutralelektrode 15 x 26 cm, 4 m Kabel	Rubber neutral electrode, 15 x 26 cm, with connection cable, 4 m	Placa neutra de goma, 15 x 26 cm, cable de conexión de 4 m
80-371-00-04	2	Gummibinden, gelocht, 100 cm	Rubber bands, with holes, 100 cm	Cintas de goma, perforadas, 100 cm
80-371-01-04	2	Knöpfe für Gummibinde	Buttons for rubber band	Botones para la cinta de goma
80-416-00-01	1	Elektroden-Ständer für 16 Elektroden	Electrode box for 16 electrodes	Caja para 16 electrodos
80-505-00-04	1	Reinigungspad für Elektroden, steril verpackt, VE = 100 Stck.	Cleaning pad for electrodes, sterile packed, SU = 100/pack	Almohadilla de limpieza para electrodos, embalado estéril, UV = 100 piezas
80-510-04-04	1	Lanzettelektrode, gerade	Lancet electrode, straight	Electrodo de lanceta, recto
80-511-04-04	1	Lanzettelektrode, abgewinkelt	Lancet electrode, angled	Electrodo de lanceta, acodado
80-515-04-04	1	Messerelektrode	Knife electrode	Electrodo de cuchillo
80-520-04-04	1	Nadelelektrode	Needle electrode	Electrodo de aguja
80-540-04-04	1	Drahtschlingenelektrode, Ø 5 mm	Wire loop electrode, Ø 5 mm	Electrodo de asa de alambre, Ø 5 mm
80-542-04-04	1	Drahtschlingenelektrode, Ø 10 mm	Wire loop electrode, Ø 10 mm	Electrodo de asa de alambre, Ø 10 mm
80-550-04-04	1	Bandschlingenelektrode, Ø 10 mm	Ribbon loop electrode, Ø 10 mm	Electrodo de asa de cinta, Ø 10 mm
80-552-04-04	1	Bandschlingenelektrode, Ø 15 mm	Ribbon loop electrode, Ø 15 mm	Electrodo de asa de cinta, Ø 15 mm
80-560-04-04	1	Kugelelektrode, Ø 2 mm	Ball electrode, Ø 2 mm	Electrodo de bola, Ø 2 mm
80-562-04-04	1	Kugelelektrode, Ø 4 mm	Ball electrode, Ø 4 mm	Electrodo de bola, Ø 4 mm
80-563-04-04	1	Kugelelektrode, Ø 5 mm	Ball electrode, Ø 5 mm	Electrodo de bola, Ø 5 mm
80-570-04-04	1	Plattenelektrode, 8 x 10 mm	Plate electrode, 8 x 10 mm	Electrodo de placa, 8 x 10 mm

<b>80-150-00-04</b>		<b>Zubehörsatz bipolar für KLS Martin maXium® m, ME MB 3/ME MB 1*</b>	<b>Set bipolar accessories for KLS Martin maXium® m, ME MB 3/ME MB 1*</b>	<b>Juego de accesorios bipolar para KLS Martin maXium® m, ME MB 3/ME MB 1*</b>
80-287-53-04	1	Anschlusskabel für bipolare Pinzetten	Connection cable for bipolar forceps	Cable de conexión para pinzas bipolares
80-924-16-04	1	Bipolare Pinzette, gerade, stumpf, 16 cm	Bipolar forceps, straight, blunt, 16 cm	Pinza bipolar, recta, roma, 16 cm
80-945-20-04	1	Bipolare Pinzette, bajonettförmig, stumpf, 20 cm	Bipolar forceps, bayonet-shaped, blunt, 20 cm	Pinza bipolar, en forma bayoneta, roma, 20 cm
80-925-16-04	1	Bipolare Pinzette, abgewinkelt, stumpf, 16 cm	Bipolar forceps, angled, blunt, 16 cm	Pinza bipolar, acodada, roma, 16 cm
80-925-20-04	1	Bipolare Pinzette, abgewinkelt, stumpf, 20 cm	Bipolar forceps, angled, blunt, 20 cm	Pinza bipolar, acodada, roma, 20 cm
80-924-20-04	1	Bipolare Pinzette, gerade, stumpf, 20 cm	Bipolar forceps, straight, blunt, 20 cm	Pinza bipolar, recta, roma, 20 cm

\* Nur in Verbindung mit Fußschalter

\* Only in connection with foot switch

\* Solamente en conexión con interruptor de pie



<b>80-140-00-04</b>		<b>Grand lot d'accessoires monopolaire pour commande digitale ME MB 3/ ME MB 1/ maXium® m, composé de:</b>	<b>Serie grande di accessori monopolare standard per attivazione a mano ME MB 3/ ME MB 1/ maXium® m, composta di:</b>
80-217-13-04	1	Manche porte-électrode smartPen avec interrupteur digital double, pour électrodes de 4 mm, avec fiche de KLS Martin	Manico portaelettrodi smartPen con due tasti, per elettrodi da 4 mm, con spina da KLS Martin
80-342-03-04	1	Electrode neutre en caoutchouc, 15 x 26 cm, avec câble de raccordement de 4 m	Elettrodo neutro di gomma, 15 x 26 cm, cavo di connessione di 4 m
80-371-00-04	2	Bandes caoutchouc, perforées, 100 cm	Nastri di gomma, perforati, 100 cm
80-371-01-04	2	Boutons pour bande caoutchouc	Bottoni per nastro di gomma
80-416-00-01	1	Boîte pour 16 électrodes	Supporto per 16 elettrodi in scatola
80-505-00-04	1	Tampon de nettoyage pour électrodes, emballage stérile, UC = 100 pièces	Tampone di pulizia per elettrodi, imballaggio sterile, UV = 100 pezzi
80-510-04-04	1	Electrode lancette, droite	Elettrodo a lancetta, retto
80-511-04-04	1	Electrode lancette, coudée	Elettrodo a lancetta, angolato
80-515-04-04	1	Electrode couteau	Elettrodo a bisturi
80-520-04-04	1	Electrode aiguille	Elettrodo ad ago
80-540-04-04	1	Electrode anse en fil, Ø 5 mm	Elettrodo ad ansa, Ø 5 mm
80-542-04-04	1	Electrode anse en fil, Ø 10 mm	Elettrodo ad ansa, Ø 10 mm
80-550-04-04	1	Electrode boucle, Ø 10 mm	Elettrodo ad ansa a nastro, Ø 10 mm
80-552-04-04	1	Electrode boucle, Ø 15 mm	Elettrodo ad ansa a nastro, Ø 15 mm
80-560-04-04	1	Electrode boule, Ø 2 mm	Elettrodo a sfera, Ø 2 mm
80-562-04-04	1	Electrode boule, Ø 4 mm	Elettrodo a sfera, Ø 4 mm
80-563-04-04	1	Electrode boule, Ø 5 mm	Elettrodo a sfera, Ø 5 mm
80-570-04-04	1	Electrode plaque, 8 x 10 mm	Elettrodo a piastra, 8 x 10 mm

<b>80-150-00-04</b>		<b>Lot d'accessoires bipolaire pour KLS Martin maXium® m, ME MB 3/ME MB 1*</b>	<b>Serie di accessori bipolare per KLS Martin maXium® m, ME MB 3/ME MB 1*</b>
80-287-53-04	1	Câble de raccordement pour pinces bipolaires	Cavo di connessione per pinze bipolari
80-924-16-04	1	Pince bipolaire, droite, mousse, 16 cm	Pinza bipolare, retta, smussa, 16 cm
80-945-20-04	1	Pince bipolaire, en forme baïonnette, mousse, 20 cm	Pinza bipolare, a forma baionetta, smussa, 20 cm
80-925-16-04	1	Pince bipolaire, coudée, mousse, 16 cm	Pinza bipolare, angolata, smussa, 16 cm
80-925-20-04	1	Pince bipolaire, coudée, mousse, 20 cm	Pinza bipolare, angolata, smussa, 20 cm
80-924-20-04	1	Pince bipolaire, droite, mousse, 20 cm	Pinza bipolare, retta, smussa, 20 cm

\* Seulement en connexion d'interrupteur à pédale

\* Solamente in connessione con interruttore a pedale

<b>80-150-01-04</b>		<b>Zubehörsatz bipolar mit nonStick-red-Pinzetten für KLS Martin maXium® m, ME MB 3/ ME MB 1*</b>	<b>Set bipolar accessories with nonStick red forceps for KLS Martin maXium® m, ME MB 3/ ME MB 1*</b>	<b>Juego de accesorios bipolar con pinzas bipolares nonStick red para KLS Martin maXium® m, ME MB 3/ ME MB 1*</b>
80-287-53-04	1	Anschlusskabel für bipolare Pinzetten	Connection cable for bipolar forceps	Cable de conexión para pinzas bipolares
80-986-17-04		Bipolare Pinzette, nonStick red, gerade, stumpf, 16 cm	Bipolar forceps, nonStick red, straight, blunt, 16 cm	Pinza bipolar, nonStick red, recta, roma, 16 cm
80-992-20-04	1	Bipolare Pinzette, nonStick red, bajonettförmig, stumpf, 20 cm	Bipolar forceps, nonStick red, bayonet-shaped, blunt, 20 cm	Pinza bipolar, nonStick red, en forma bayoneta, roma, 20 cm
80-987-17-04	1	Bipolare Pinzette, nonStick red, abgewinkelt, stumpf, 16 cm	Bipolar forceps, nonStick red, angled, blunt, 16 cm	Pinza bipolar, nonStick red, acodada, roma, 16 cm
80-987-20-04	1	Bipolare Pinzette, nonStick red, abgewinkelt, stumpf, 20 cm	Bipolar forceps, nonStick red, angled, blunt, 20 cm	Pinza bipolar, nonStick red, acodada, roma, 20 cm
80-986-20-04	1	Bipolare Pinzette, nonStick red, gerade, stumpf, 20 cm	Bipolar forceps, nonStick red, straight, blunt, 20 cm	Pinza bipolar, nonStick red, recta, roma, 20 cm

\* Nur in Verbindung mit Fußschalter

\* Only in connection with foot switch

\* Solamente en conexión con interruptor de pie

<b>80-140-01-04</b>		<b>Großer Zubehörsatz, Fußaktivierung für ME MB 3/ ME MB 1/ maXium® m, bestehend aus:</b>	<b>Accessory set, large for foot switch operation ME MB 3/ ME MB 1/ maXium® m, consisting of:</b>	<b>Juego de accesorios, grande con interruptor de pedal ME MB 3/ ME MB 1/ maXium® m, compuesto de:</b>
80-220-02-04	1	smartPen Elektroden-Handgriff ohne Tasten für 4-mm-Elektroden, mit KLS Martin-Stecker	smartPen electrode handle without pushbuttons for 4-mm electrodes, with KLS Martin plug	Mango porta-electrodos smartPen sin teclas, para electrodos de 4 mm, con clavija de KLS Martin
80-342-03-04	1	Gummi-Neutralelektrode 15 x 26 cm, 4 m Kabel	Rubber neutral electrode, 15 x 26 cm, with connection cable of 4 m	Placa neutra de goma, 15 x 26 cm, cable de conexión de 4 m
80-371-00-04	2	Gummibinden, gelocht, 100 cm	Rubber bands, with holes, 100 cm	Cintas de goma, perforadas, 100 cm
80-371-01-04	2	Knöpfe für Gummibinde	Buttons for rubber band	Botones para la cinta de goma
80-416-00-01	1	Elektroden-Ständer für 16 Elektroden	Electrode box for 16 electrodes	Caja para 16 electrodos
80-505-00-04	1	Reinigungspad für Elektroden, steril verpackt, VE = 100 Stck.	Cleaning pad for electrodes, sterile packed, SU = 100/pack	Almohadilla de limpieza para electrodos, embalado estéril, UV = 100 piezas
80-510-04-04	1	Lanzettelektrode, gerade	Lancet electrode, straight	Electrodo de lanceta, recto
80-511-04-04	1	Lanzettelektrode, abgewinkelt	Lancet electrode, angled	Electrodo de lanceta, acodado
80-515-04-04	1	Messerelektrode	Knife electrode	Electrodo de cuchillo
80-520-04-04	1	Nadelelektrode	Needle electrode	Electrodo de aguja
80-540-04-04	1	Drahtschlingenelektrode, Ø 5 mm	Wire loop electrode, Ø 5 mm	Electrodo de asa de alambre, Ø 5 mm
80-542-04-04	1	Drahtschlingenelektrode, Ø 10 mm	Wire loop electrode, Ø 10 mm	Electrodo de asa de alambre, Ø 10 mm
80-550-04-04	1	Bandschlingenelektrode, Ø 10 mm	Ribbon loop electrode, Ø 10 mm	Electrodo de asa de cinta, Ø 10 mm
80-552-04-04	1	Bandschlingenelektrode, Ø 15 mm	Ribbon loop electrode, Ø 15 mm	Electrodo de asa de cinta, Ø 15 mm
80-560-04-04	1	Kugelelektrode, Ø 2 mm	Ball electrode, Ø 2 mm	Electrodo de bola, Ø 2 mm
80-562-04-04	1	Kugelelektrode, Ø 4 mm	Ball electrode, Ø 4 mm	Electrodo de bola, Ø 4 mm
80-563-04-04	1	Kugelelektrode, Ø 5 mm	Ball electrode, Ø 5 mm	Electrodo de bola, Ø 5 mm
80-570-04-04	1	Plattenelektrode, 8 x 10 mm	Plate electrode, 8 x 10 mm	Electrodo de placa, 8 x 10 mm
80-830-00-04	1	Doppelpedal-Fußschalter, AP-geprüft, 5 m Kabel, explosionsgeschützt	Double-pedal foot switch, anti-explosive, with connection cable of 5 m	Interruptor de pedal doble, anti-explosivo, cable de conexión de 5 m





<b>80-150-01-04</b>		<b>Lot d'accessoires bipolaire avec pinces bipolaires nonStick red pour KLS Martin maXium® m, ME MB 3/ ME MB 1*</b>	<b>Serie di accessori bipolare con pinze bipolari nonStick red per KLS Martin maXium® m, ME MB 3/ ME MB 1*</b>
80-287-53-04	1	Câble de raccordement pour pinces bipolaires	Cavo di connessione per pinze bipolari
80-986-17-04		Pince bipolaire, nonStick red, droite, mousse, 16 cm	Pinza bipolare, nonStick red, retta, smussa, 16 cm
80-992-20-04	1	Pince bipolaire, nonStick red, en forme baïonnette, mousse, 20 cm	Pinza bipolare, nonStick red, a forma baionetta, smussa, 20 cm
80-987-17-04	1	Pince bipolaire, nonStick red, coudée, mousse, 16 cm	Pinza bipolare, nonStick red, angolata, smussa, 16 cm
80-987-20-04	1	Pince bipolaire, nonStick red, coudée, mousse, 20 cm	Pinza bipolare, nonStick red, angolata, smussa, 20 cm
80-986-20-04	1	Pince bipolaire, nonStick red, droite, mousse, 20 cm	Pinza bipolare, nonStick red, retta, smussa, 20 cm

\* Seulement en connexion d'interrupteur à pédale

\* Solamente in connessione con interruttore a pedale

<b>80-140-01-04</b>		<b>Grand lot d'accessoires pour commande par pédale ME MB 3/ ME MB 1/ maXium® m, composé de:</b>	<b>Serie grande di accessori standard per attivazione a pedale ME MB 3/ ME MB 1/ maXium® m, composta di:</b>
80-220-02-04	1	Manche porte-électrode smartPen sans interrupteur, pour électrodes de 4 mm, avec fiche de KLS Martin	Manico portaelettrodi smartPen senza tasti, per elettrodi da 4 mm, con spina da KLS Martin
80-342-03-04	1	Electrode neutre en caoutchouc, 15 x 26 cm, avec câble de raccordement de 4 m	Elettrodo neutro di gomma, 15 x 26 cm, cavo di connessione di m 4
80-371-00-04	2	Bandes caoutchouc, perforées, 100 cm	Nastri di gomma, perforati, 100 cm
80-371-01-04	2	Boutons pour bande caoutchouc	Bottoni per nastro di gomma
80-416-00-01	1	Boîte pour 16 électrodes	Supporto per 16 elettrodi in scatola
80-505-00-04	1	Tampon de nettoyage pour électrodes, emballage stérile, UC = 100 pièces	Tampone di pulizia per elettrodi, imballaggio sterile, UV = 100 pezzi
80-510-04-04	1	Electrode lancette, droite	Elettrodo a lancetta, retto
80-511-04-04	1	Electrode lancette, coudée	Elettrodo a lancetta, angolato
80-515-04-04	1	Electrode couteau	Elettrodo a bisturi
80-520-04-04	1	Electrode aiguille	Elettrodo ad ago
80-540-04-04	1	Electrode anse en fil, Ø 5 mm	Elettrodo ad ansa, Ø 5 mm
80-542-04-04	1	Electrode anse en fil, Ø 10 mm	Elettrodo ad ansa, Ø 10 mm
80-550-04-04	1	Electrode boucle, Ø 10 mm	Elettrodo ad ansa a nastro, Ø 10 mm
80-552-04-04	1	Electrode boucle, Ø 15 mm	Elettrodo ad ansa a nastro, Ø 15 mm
80-560-04-04	1	Electrode boule, Ø 2 mm	Elettrodo a sfera, Ø 2 mm
80-562-04-04	1	Electrode boule, Ø 4 mm	Elettrodo a sfera, Ø 4 mm
80-563-04-04	1	Electrode boule, Ø 5 mm	Elettrodo a sfera, Ø 5 mm
80-570-04-04	1	Electrode plaque, 8 x 10 mm	Elettrodo a piastra, 8 x 10 mm
80-830-00-04	1	Interrupteur à pédale double, anti-explosif, avec câble de raccordement de 5 m	Interruttore a pedale doppio, anti-deflagrante, con cavo di connessione di 5 m

Zubehörsätze für Großgeräte  
 Accessory sets for major electrosurgery units  
 Juegos de accesorios para gran aparatos  
 Jeux d'accessoires pour grands appareils  
 Serie di accessori per apparecchi grandi

<b>80-140-02-04</b>		<b>Kleiner Zubehörsatz, Handaktivierung für ME MB 3/ ME MB 1/ maXium® m, bestehend aus:</b>	<b>Accessory set, small for hand switch operation ME MB 3/ ME MB 1/ maXium® m, consisting of:</b>	<b>Juego de accesorios, pequeño con interruptor digital ME MB 3/ ME MB 1/ maXium® m, compuesto de:</b>
80-217-13-04	1	smartPen Elektroden-Handgriff mit zwei Tasten für 4-mm-Elektroden, mit KLS Martin-Stecker	smartPen electrode handle with two pushbuttons for 4-mm electrodes, with KLS Martin plug	Mango porta-electrodos smartPen con dos teclas, para electrodos de 4 mm, con clavija de KLS Martin
80-342-03-04	1	Gummi-Neutralelektrode 15 x 26 cm, 4 m Kabel	Rubber neutral electrode, 15 x 26 cm, with connection cable of 4 m	Placa neutra de goma, 15 x 26 cm, cable de conexión de 4 m
80-372-00-04	1	Textilband mit Klettverschluss, 90 cm	Textile band with velcro strap, 90 cm	Tira auto-adhesiva, 90 cm
80-505-00-04	1	Reinigungspad für Elektroden, steril verpackt, VE = 100 Stck.	Cleaning pad for electrodes, sterile packed, SU = 100/pack	Almohadilla de limpieza para electrodos, embalado estéril, UV = 100 piezas
80-511-04-04	1	Lanzettelektrode, abgewinkelt	Lancet electrode, straight	Electrodo de lanceta, acodado
80-515-04-04	1	Messerelektrode	Knife electrode	Electrodo de cuchillo
80-520-04-04	1	Nadelelektrode	Needle electrode	Electrodo de aguja
80-562-04-04	1	Kugelelektrode, Ø 4 mm	Ball electrode, Ø 4 mm	Electrodo de bola, Ø 4 mm

Ergänzungs-Sets

Supplementary sets

Juegos suplementarios

<b>80-160-00-04</b>		<b>Standard-Set A für ME MB 3 m, ME MB 1 (und andere KLS-Martin-Großgeräte) bestehend aus:</b>	<b>Standard Set A for ME MB 3 m, ME MB 1 (and other KLS Martin major electrosurgery units) consisting of:</b>	<b>Juego estándar A para ME MB 3 m, ME MB 1 (y otros equipos grandes KLS Martin) compuesto de:</b>
80-221-02-04	1	Einmalhandgriffe, VE = 10 Stck.	Disposable electrode handles, SU = 10/pack	Mangos desechables, UV = 10 piezas
80-344-09-04	1	PCS-DuoSafe-Einmal-Neutralelektroden, VE = 50 Stck.	Disposable DuoSafe neutral electrodes, SU = 50/pack	Placas neutras desechables PCS DuoSafe, UV = 50 piezas
80-294-40-04	1	Neutralelektroden-Anschlusskabel KLS Martin	KLS Martin connection cable for disposable neutral electrodes	Cable de conexión KLS Martin para placa neutra
80-505-00-04	1	Reinigungspad für Elektroden, steril verpackt, VE = 100 Stck.	Cleaning pad for electrodes, sterile packed, SU = 100/pack	Almohadilla de limpieza para electrodos, embalado estéril, UV = 100 piezas
80-830-00-04	1	Doppelpedal-Fußschalter	Double-pedal foot switch	Interruptor de pie de doble pedal

<b>80-160-01-04</b>		<b>Standard-Set B für ME MB 3 i und ME MB 2 i maXium® i, bestehend aus:</b>	<b>Standard Set B for ME MB 3 i and ME MB 2 i maXium® i, consisting of:</b>	<b>Juego estándar B para ME MB 3 i y ME MB 2 i maXium® i, compuesto de:</b>
80-221-02-04	1	Einmalhandgriffe, VE = 10 Stck.	Disposable electrode handles, SU = 10/pack	Mangos desechables, UV = 10 piezas
80-344-09-04	1	PCS-DuoSafe-Einmal-Neutralelektroden, VE = 50 Stck.	Disposable DuoSafe neutral electrodes, SU = 50/pack	Placas neutras desechables PCS DuoSafe, UV = 50 piezas
80-294-44-04	1	Neutralelektroden-Anschlusskabel Valleylab	Connection cable Valleylab for disposable neutral electrodes	Cable de conexión Valleylab para electrodo neutro
80-505-00-04	1	Reinigungspad für Elektroden, steril verpackt, VE = 100 Stck.	Cleaning pad for electrodes, sterile packed, SU = 100/pack	Almohadilla de limpieza para electrodos, embalado estéril, UV = 100 piezas
80-830-00-04	1	Doppelpedal-Fußschalter	Double-pedal foot switch	Interruptor de pie de doble pedal



<b>80-140-02-04</b>		<b>Petit lot d'accessoires pour commande digitale ME MB 3/ ME MB 1/ maXium® m, composé de:</b>	<b>Serie piccola di accessori standard per attivazione a mano ME MB 3/ ME MB 1/ maXium® m, composta di:</b>
80-217-13-04	1	Manche porte-électrode smartPen avec interrupteur digital double, pour électrodes de 4 mm, avec fiche de KLS Martin	Manico portaelettrodi smartPen con due tasti, per elettrodi da 4 mm, con spina da KLS Martin
80-342-03-04	1	Electrode neutre en caoutchouc, 15 x 26 cm, avec câble de raccordement de 4 m	Elettrodo neutro di gomma, 15 x 26 cm, cavo di connessione di 4 m
80-372-00-04	1	Bande auto-adhésive, 90 cm	Nastro tessile auto-adesivo, 90 cm
80-505-00-04	1	Tampon de nettoyage pour électrodes, emballage stérile, UC = 100 pièces	Tampone di pulizia per elettrodi, imballaggio sterile, UV = 100 pezzi
80-511-04-04	1	Electrode lancette, coudée	Elettrodo a lancetta, angolato
80-515-04-04	1	Electrode couteau	Elettrodo a bisturi
80-520-04-04	1	Electrode aiguille	Elettrodo ad ago
80-562-04-04	1	Electrode boule, Ø 4 mm	Elettrodo a sfera, Ø 4 mm

Lots supplémentaires

Set supplementari

<b>80-160-00-04</b>		<b>Lot standard A pour ME MB 3 m, ME MB 1 (et autres grands appareils KLS Martin) composé de:</b>	<b>Set standard A per l'apparecchio ME MB 3 m, ME MB 1 (e altri grandi apparecchi KLS Martin) composto di:</b>
80-221-02-04	1	Manches à usage unique, UC = 10 pièces	Manici monouso, UV = 10 pezzi
80-344-09-04	1	Électrodes neutres à usage unique type PCS DuoSafe, UC = 50 pièces	Elettrodi neutri PCS DuoSafe monouso, UV = 50 pezzi
80-294-40-04	1	Câble de raccordement à électrode neutre KLS Martin	Cavo di connessione KLS Martin per elettrodo neutro
80-505-00-04	1	Tampon de nettoyage pour électrodes, emballage stérile, UC = 100 pièces	Tampone di pulizia per elettrodi, imballaggio sterile, UV = 100 pezzi
80-830-00-04	1	Interrupteur à pédale double	Interruttore a pedale doppio

13

<b>80-160-01-04</b>		<b>Lot standard B pour ME MB 3 i et ME MB 2 i maXium® i, composé de:</b>	<b>Set standard B per l'apparecchio ME MB 3 i e ME MB 2 i maXium® i, composto di:</b>
80-221-02-04	1	Manches à usage unique, UC = 10 pièces	Manici monouso, UV = 10 pezzi
80-344-09-04	1	Électrodes neutres à usage unique type PCS DuoSafe, UC = 50 pièces	Elettrodi neutri PCS DuoSafe monouso, UV = 50 pezzi
80-294-44-04	1	Câble de raccordement à électrode neutre Valleylab	Cavo di connessione Valleylab per elettrodo neutro
80-505-00-04	1	Tampon de nettoyage pour électrodes, emballage stérile, UC = 100 pièces	Tampone di pulizia per elettrodi, imballaggio sterile, UV = 100 pezzi
80-830-00-04	1	Interrupteur à pédale double	Interruttore a pedale doppio

80-160-02-04		<b>Standard-Set C für ME MB 3 i, ME MB 2 i, maXium® i (und weitere Geräte mit internationalem Anschluss) bestehend aus:</b>	<b>Standard set C for ME MB 3 i, ME MB 2 i, maXium® i (and other units with international connector sockets) consisting of:</b>	<b>Juego estándar C para ME MB 3 i, ME MB 2 i, maXium® i (y otros equipos con conexión internacional) compuesto de:</b>
80-210-02-04	1	smartPen Elektroden-Handgriff ohne Tasten für 2,4-mm-Elektroden, mit KLS Martin-Stecker	smartPen electrode handle without pushbuttons, for 2.4-mm electrodes, with KLS Martin plug	Mango porta-electrodos smartPen sin teclas, para electrodos de 2,4 mm, con clavija de KLS Martin
80-562-08-04	5	Kugelelektrode Ø 4 mm	Ball electrode Ø 4 mm,	Electrodo de bola Ø 4 mm,
80-520-08-04	5	Nadelelektrode	Needle electrode	Electrodo de aguja,
80-515-08-04	5	Messerelektrode	Knife electrode	Electrodo de cuchillo
80-510-08-04	5	Lanzettelektrode	Lancet electrode,	Electrodo de lanceta
80-542-08-04	5	Drahtschlingenelektrode Ø 10 mm	Wire loop electroe Ø 10 mm	Electrodo de asa de alambre Ø 10 mm
80-344-09-04	1	PCS-DuoSafe-Einmal-Neutralelektroden, VE = 50 Stck.	Disposable DuoSafe neutral electrodes, SU = 50/pack	Placas neutras desechables PCS DuoSafe, UV = 50 piezas
80-294-44-04	1	Neutralelektroden-Anschlusskabel mit i-Stecker (Typ Valleylab)	Connection cable for neutral electrodes with „i“-Version plug (type Valleylab)	Cable de conexión para placas neutras con clavija versión "i" (tipo Valleylab)
80-830-00-04	1	Doppelpedal-Fußschalter	Double-pedal foot switch	Interruptor de pie doble
80-505-00-04	1	Reinigungspad für Elektroden, steril verpackt, VE = 100 Stck.	Cleaning pad for electrodes, sterile packed, SU = 100/pack	Almohadilla de limpieza para electrodos, embalado estéril, UV = 100 piezas



<b>80-160-02-04</b>		<b>Lot standard C pour ME MB 3 i, ME MB 2 i, maXium® i (et autres appareils avec connexion internationale) composé de:</b>	<b>Set standard C per l'apparecchio ME MB 3 i, ME MB 2 i, maXium® i (e altri apparecchi con connessione internazionale) composto di:</b>
80-210-02-04	5	Manche porte-électrode smartPen sans interrupteur pour 2,4 mm électrodes, avec fiche KLS Martin	Manico portaelettrodi smartPen senza tasti per 2,4 mm elettrodi, con spina KLS Martin
80-562-08-04	5	Electrode boule Ø 4 mm	Elettrodo a sfera Ø 4 mm
80-520-08-04	5	Electrode aiguille	Elettrodo ad ago
80-515-08-04	5	Electrode couteau	Elettrodo a bisturi
80-510-08-04	5	Electrode lancette	Elettrodo a lancetta
80-542-08-04	5	Electrode anse en fil Ø 10 mm	Elettrodo ad ansa di filo Ø 10 mm
80-344-09-04	1	Électrodes neutres à usage unique type PCS DuoSafe, UC = 50 pièces	Elettrodi neutri PCS DuoSafe monouso, UV = 50 pezzi
80-294-44-04	1	Câble de raccordement pour électrodes neutres avec fiche version «i» (type Valleylab)	Cavo di connessione per elettrodi neutri con spina versione "i" (tipo Valleylab)
80-811-30-04	1	Interrupteur à pédale double	Interruttore a doppio pedale
80-505-00-04	1	Tampon de nettoyage pour électrodes, emballage stérile, UC = 100 pièces	Tampone di pulizia per elettrodi, imballaggio sterile, UV = 100 pezzi

maXium®-Zubehörsätze für die Offene Chirurgie  
 maXium® accessory sets for open surgery  
 Juegos de accesorios maXium® para la cirugía abierta  
 Jeux d'accessoires maXium® pour la chirurgie ouverte  
 Serie di accessori maXium® per la chirurgia aperta

80-042-10-04		Satz Zubehör für maXium® m, bestehend aus:	Accessory set for maXium® m, consisting of:	Juego de accesorios para maXium® m, compuesto de:
80-830-01-04	1	SWAP-Mode-Doppelpedalfußschalter	SWAP mode double-pedal foot switch	Interruptor de pie de doble pedal con modo SWAP
80-830-02-04	1	Einpedalfußschalter	Single-pedal foot switch	Interruptor de pie de un pedal
80-260-50-04	1	Potentialausgleichskabel	Potential equalization cable	Cable de conexión equipotencial
80-217-13-04	2	smartPen Elektroden-Handgriff mit zwei Tasten, für 4-mm-Elektroden, mit KLS Martin-Stecker	smartPen electrode handle with two pushbuttons, for 4-mm electrodes, with KLS Martin plug	Mango porta-electrodos smartPen con dos teclas, para electrodos de 4 mm, con clavija de KLS Martin
80-510-04-04	2	Lanzettelektrode	Lancet electrode	Electrodo de lanceta
80-511-04-04	2	Lanzettelektrode, abgewinkelt	Lancet electrode, angled	Electrodo de lanceta, acodado
80-515-04-04	2	Messerelektrode	Knife electrode	Electrodo de cuchillo
80-560-04-04	2	Kugelelektrode Ø 2 mm	Ball electrode Ø 2 mm	Electrodo de bola Ø 2 mm
80-344-09-04	1	PCS-DuoSafe-Einmal-Neutralelektroden, VE = 50 Stck.	Disposable DuoSafe neutral electrodes, SU = 50/pack	Placas neutras desechables PCS DuoSafe UV = 50 piezas
80-294-40-04	1	Anschlusskabel für Neutralelektroden	Connection cable for neutral electrodes	Cable de conexión para placas neutras
80-924-16-04	2	Bipolare Pinzette, gerade, stumpf	Bipolar forceps, straight, blunt	Pinzas bipolares, rectas, romas
80-287-33-04	4	Anschlusskabel für bipolare Instrumente	Connection cable for bipolar instruments	Cable de conexión para instrumentos bipolares
80-975-23-04	2	marClamp® IQ, gebogene Version, 23 cm	marClamp® IQ, curved version, 23 cm	marClamp® IQ, versión curva, 23 cm
80-570-23-04	2	marCut®, 23 cm	marCut®, 23 cm	marCut®, 23 cm
80-505-00-04	1	Reinigungspad für Elektroden, steril verpackt, VE = 100 Stck.	Cleaning pad for electrodes, sterile packed, SU = 100/pack	Almohadilla de limpieza para electrodos, embalado estéril, UV = 100 piezas

80-042-20-04		Satz Zubehör für maXium® i, bestehend aus:	Accessory set for maXium® i, consisting of:	Juego de accesorios para maXium® i, compuesto de:
80-830-01-04	1	SWAP-Mode-Doppelpedalfußschalter	SWAP mode double-pedal foot switch	Interruptor de pie de doble pedal con modo SWAP
80-830-02-04	1	Einpedalfußschalter	Single-pedal foot switch	Interruptor de pie de un pedal,
80-260-50-04	1	Potentialausgleichskabel	Potential equalization cable	Cable de conexión equipotencial
80-210-13-04	2	smartPen Elektroden-Handgriff mit zwei Tasten für 4-mm-Elektroden, mit 3-PIN-Stecker	smartPen electrode handle with two pushbuttons, for 4-mm electrodes, with 3-pin plug	Mango porta-electrodos smartPen con dos teclas, para electrodos 4 mm, con clavija de 3 patillas
80-510-04-04	2	Lanzettelektrode	Lancet electrode	Electrodo de lanceta
80-511-04-04	2	Lanzettelektrode, abgewinkelt	Lancet electrode, angled	Electrodo de lanceta, acodado
80-515-04-04	2	Messerelektrode	Knife electrode	Electrodo de cuchillo
80-560-04-04	2	Kugelelektrode Ø 2 mm	Ball electrode Ø 2 mm	Electrodo de bola Ø 2 mm
80-344-09-04	1	PCS-DuoSafe-Einmal-Neutralelektroden, VE = 50 Stck.	Disposable DuoSafe neutral electrodes, SU = 50/pack	Placas neutras desechables PCS DuoSafe UV = 50 piezas
80-294-40-04	1	Anschlusskabel für Neutralelektroden	Connection cable for neutral electrodes	Cable de conexión para placas neutras
80-924-16-04	2	Bipolare Pinzette, gerade, stumpf	Bipolar forceps, straight, blunt	Pinzas bipolares, rectas, romas
80-287-89-04	4	Anschlusskabel für bipolare Instrumente	Connection cable for bipolar instruments	Cable de conexión para instrumentos bipolares
80-975-23-04	2	marClamp® IQ, gebogene Version, 23 cm	marClamp® IQ, curved version, 23 cm	marClamp® IQ, versión curva, 23 cm
80-570-23-04	2	marCut®, 23 cm	marCut®, 23 cm	marCut®, 23 cm
80-505-00-04	1	Reinigungspad für Elektroden, steril verpackt, VE = 100 Stck.	Cleaning pad for electrodes, sterile packed, SU = 100/pack	Almohadilla de limpieza para electrodos, embalado estéril, UV = 100 piezas



<b>80-042-10-04</b>		<b>Lot d'accessoires pour maXium® m, composé de:</b>	<b>Serie di accessori per maXium® m, composta di:</b>
80-830-01-04	1	Interrupteur à pédale double avec mode SWAP	Interruttore a pedale doppio con modo SWAP
80-830-02-04	1	Interrupteur à une pédale	Interruttore monopedale,
80-260-50-04	1	Câble de compensation de potentiel	Cavo per collegamento equipotenziale
80-217-13-04	2	Manche porte-électrode smartPen avec interrupteur digital double, pour électrodes de 4 mm, avec fiche de KLS Martin	Manico portaelettrodi smartPen con due tasti, per elettrodi da 4 mm, con spina da KLS Martin
80-510-04-04	2	Electrode lancette	Elettrodo a lancetta
80-511-04-04	2	Electrode lancette, coudée	Elettrodo a lancetta, angolato
80-515-04-04	2	Electrode couteau	Elettrodo a bisturi
80-560-04-04	2	Electrode boule Ø 2 mm	Elettrodo a sfera Ø 2 mm
80-344-09-04	1	Electrodes neutres à usage unique type PCS DuoSafe UC = 50 pièces	Elettrodi neutri PCS DuoSafe monouso UV = 50 pezzi
80-294-40-04	1	Câble de raccordement pour électrodes neutres	Cavo di connessione per elettrodi neutri
80-924-16-04	2	Pinces bipolaires, droites, mousses	Pinze bipolari, strette, smusse
80-287-33-04	4	Câble de raccordement pour instruments bipolaires	Cavo di connessione per strumenti bipolari
80-975-23-04	2	marClamp® IQ, version courbe, 23 cm	marClamp® IQ, versione curva, 23 cm
80-570-23-04	2	marCut®, 23 cm	marCut®, 23 cm
80-505-00-04	1	Tampon de nettoyage pour électrodes, emballage stérile, UC = 100 pièces	Tampone di pulizia per elettrodi, imballaggio sterile, UV = 100 pezzi

<b>80-042-20-04</b>		<b>Lot d'accessoires pour maXium® i, composé de:</b>	<b>Serie di accessori per maXium® i, composta di:</b>
80-830-01-04	1	Interrupteur à pédale double avec mode SWAP	Interruttore a pedale doppio con modo SWAP
80-830-02-04	1	Interrupteur à une pédale	Interruttore monopedale
80-260-50-04	1	Câble de compensation de potentiel	Cavo per collegamento equipotenziale
80-210-13-04	2	Manche porte-électrode smartPen avec interrupteur digital double, pour électrodes de 4 mm, avec fiche à 3 broches	Manico portaelettrodi smartPen con due tasti, per elettrodi da 4 mm, con spina a 3-spire
80-510-04-04	2	Electrode lancette	Elettrodo a lancetta
80-511-04-04	2	Electrode lancette, coudée	Elettrodo a lancetta, angolato
80-515-04-04	2	Electrode couteau	Elettrodo a bisturi
80-560-04-04	2	Electrode boule Ø 2 mm	Elettrodo a sfera Ø 2 mm
80-344-09-04	1	Electrodes neutres à usage unique type PCS DuoSafe UC = 50 pièces	Elettrodi neutri PCS DuoSafe monouso UV = 50 pezzi
80-294-40-04	1	Câble de raccordement pour électrodes neutres	Cavo di connessione per elettrodi neutri
80-924-16-04	2	Pinces bipolaires, droites, mousses	Pinze bipolari, strette, smusse
80-287-89-04	4	Câble de raccordement pour instruments bipolaires	Cavo di connessione per strumenti bipolari
80-975-23-04	2	marClamp® IQ, version courbe, 23 cm	marClamp® IQ, versione curva, 23 cm
80-570-23-04	2	marCut®, 23 cm	marCut®, 23 cm
80-505-00-04	1	Tampon de nettoyage pour électrodes, emballage stérile, UC = 100 pièces	Tampone di pulizia per elettrodi, imballaggio sterile, UV = 100 pezzi

maXium®-Zubehörsätze für die Offene Chirurgie  
 maXium® accessory sets for open surgery  
 Juegos de accesorios maXium® para la cirugía abierta  
 Jeux d'accessoires maXium® pour la chirurgie ouverte  
 Serie di accessori maXium® per la chirurgia aperta

80-042-40-04		Satz Zubehör für maXium® e, bestehend aus:	Accessory set for maXium® e, consisting of:	Juego de accesorios para maXium® e, compuesto de:
80-830-01-04	1	SWAP-Mode-Doppelpedalfußschalter	SWAP mode double-pedal foot switch	Interruptor de pie de doble pedal con modo SWAP
80-830-02-04	1	Einpedalfußschalter	Single-pedal foot switch	Interruptor de pie de un pedal
80-260-50-04	1	Potentialausgleichskabel	Potential equalization cable	Cable de conexión equipotencial
80-210-18-04	2	smartPen Elektroden-Handgriff mit zwei Tasten für 4-mm-Elektroden, mit Erbe-Stecker	smartPen electrode handle with two pushbuttons, for 4-mm electrodes, with Erbe plug	Mango porta-electrodos smartPen con dos teclas, para electrodos 4 mm, con clavija de Erbe
80-510-04-04	2	Lanzettelektrode	Lancet electrode	Electrodo de lanceta
80-511-04-04	2	Lanzettelektrode, abgewinkelt	Lancet electrode, angled	Electrodo de lanceta, acodado
80-515-04-04	2	Messerelektrode	Knife electrode	Electrodo de cuchillo
80-560-04-04	2	Kugелеlektrode Ø 2 mm	Ball electrode Ø 2 mm	Electrodo de bola Ø 2 mm
80-344-09-04	1	PCS-DuoSafe-Einmal-Neutralelektroden, VE = 50 Stck.	Disposable DuoSafe neutral electrodes, SU = 50/pack	Placas neutras desechables PCS DuoSafe UV = 50 piezas
80-294-40-04	1	Anschlusskabel für Neutralelektroden	Connection cable for neutral electrodes	Cable de conexión para placas neutras
80-924-16-04	2	Bipolare Pinzette, gerade, stumpf	Bipolar forceps, straight, blunt	Pinzas bipolares, rectas, romas
80-287-89-04	4	Anschlusskabel für bipolare Instrumente	Connection cable for bipolar instruments	Cable de conexión para instrumentos bipolares
80-975-23-04	2	marClamp® IQ, gebogene Version, 23 cm	marClamp® IQ, curved version, 23 cm	marClamp® IQ, versión curva, 23 cm
80-570-23-04	2	marCut®, 23 cm	marCut®, 23 cm	marCut®, 23 cm
80-505-00-04	1	Reinigungspad für Elektroden, steril verpackt, VE = 100 Stck.	Cleaning pad for electrodes, sterile packed, SU = 100/pack	Almohadilla de limpieza para electrodos, embalado estéril, UV = 100 piezas





<b>80-042-40-04</b>		<b>Lot d'accessoires pour maXium® e, composé de:</b>	<b>Serie di accessori per maXium® e, composta di:</b>
80-830-01-04	1	Interrupteur à pédale double avec mode SWAP	Interruttore a pedale doppio con modo SWAP
80-830-02-04	1	Interrupteur à une pédale	Interruttore monopedale
80-260-50-04	1	Câble de compensation de potentiel	Cavo per collegamento equipotenziale
80-210-18-04	2	Manche porte-électrode smartPen avec interrupteur digital double, pour électrodes de 4 mm, avec fiche de Erbe	Manico portaelettrodi smartPen con due tasti, per elettrodi da 4 mm, con spina da Erbe
80-510-04-04	2	Electrode lancette	Elettrodo a lancetta
80-511-04-04	2	Electrode lancette, coudée	Elettrodo a lancetta, angolato
80-515-04-04	2	Electrode couteau	Elettrodo a bisturi
80-560-04-04	2	Electrode boule Ø 2 mm	Elettrodo a sfera Ø 2 mm
80-344-09-04	1	Electrodes neutres à usage unique type PCS DuoSafe UC = 50 pièces	Elettrodi neutri PCS DuoSafe monouso UV = 50 pezzi
80-294-40-04	1	Câble de raccordement pour électrodes neutres	Cavo di connessione per elettrodi neutri
80-924-16-04	2	Pinces bipolaires, droites, mousses	Pinze bipolari, strette, smusse
80-287-89-04	4	Câble de raccordement pour instruments bipolaires	Cavo di connessione per strumenti bipolari
80-975-23-04	2	marClamp® IQ, version courbe, 23 cm	marClamp® IQ, versione curva, 23 cm
80-570-23-04	2	marCut®, 23 cm	marCut®, 23 cm
80-505-00-04	1	Tampon de nettoyage pour électrodes, emballage stérile, UC = 100 pièces	Tampone di pulizia per elettrodi, imballaggio sterile, UV = 100 pezzi

maXium®-Beamer-Zubehörsätze für die Offene Chirurgie  
 maXium® Beamer accessory sets for open surgery  
 Juegos de accesorios maXium® Beamer para la cirugía abierta  
 Jeux d'accessoires maXium® Beamer pour la chirurgie ouverte  
 Serie di accessori maXium® Beamer per la chirurgia aperta

80-042-11-04		Satz Zubehör für maXium® m, bestehend aus:	Accessory set for maXium® m, consisting of:	Juego de accesorios para maXium® m, compuesto de:
80-181-52-04	1	Druckminderer (D, A, ...)	Pressure reducer (D, A, ...)	Manorreductor (D, A, ...)
80-830-01-04	1	SWAP-Mode-Doppelpedalfußschalter	SWAP mode double-pedal foot switch	Interruptor de pie de doble pedal con modo SWAP
80-830-02-04	1	Einpedalfußschalter	Single-pedal foot switch	Interruptor de pie de un pedal
80-260-50-04	1	Potentialausgleichskabel	Potential equalization cable	Cable de conexión equipotencial
80-181-02-04	2	MABS-Handgriff für starre Applikatoren	MABS handle for rigid applicators	Mango MABS para aplicadores rígidos
80-181-10-04	2	MABS-Beam-Elektrode	MABS beam electrode	Electrodo MABS Beam
80-181-13-04	2	MABS-Lanzetten-Elektrode	MABS lancet electrode	Electrodo de lanceta MABS
80-181-15-04	2	MABS-Nadel-Elektrode	MABS needle electrode	Electrodo de aguja MABS
80-344-09-04	1	PCS-DuoSafe-Einmal-Neutralelektroden, VE = 50 Stck.	PCS disposable neutral electrode, SU = 50/pack	Placas neutras desechables PCS DuoSafe UV = 50 piezas
80-294-40-04	1	Anschlusskabel für Neutralelektroden	Connection cable for neutral electrodes	Cable de conexión para placas neutras
80-924-16-04	2	Bipolare Pinzette, gerade, stumpf	Bipolar forceps, straight, blunt	Pinzas bipolares, rectas, romas
80-287-33-04	4	Anschlusskabel für bipolare Instrumente	Connection cable for bipolar instruments	Cable de conexión para instrumentos bipolares
		<b>Optional:</b>	<b>Optional:</b>	<b>Opcional:</b>
80-975-23-04	2	marClamp® IQ, gebogene Version, 23 cm	marClamp® IQ, curved version, 23 cm	marClamp® IQ, versión curva, 23 cm
80-570-23-04	2	marCut®, 23 cm	marCut®, 23 cm	marCut®, 23 cm

80-042-21-04		Satz Zubehör für maXium® i, bestehend aus:	Accessory set for maXium® i, consisting of:	Juego de accesorios para maXium® i, compuesto de:
80-181-53-04	1	Druckminderer (NL, DK, ...)	Pressure reducer (D, A, ...)	Manorreductor (NL, DK, ...)
80-830-01-04	1	SWAP-Mode-Doppelpedalfußschalter	SWAP mode double-pedal foot switch	Interruptor de pie de doble pedal con modo SWAP,
80-830-02-04	1	Einpedalfußschalter	Single-pedal foot switch	Interruptor de pie de un pedal
80-260-50-04	1	Potentialausgleichskabel	Potential equalization cable	Cable de conexión equipotencial
80-181-02-04	2	MABS-Handgriff für starre Applikatoren	MABS handle for rigid applicators	Mango MABS para aplicadores rígidos
80-181-10-04	2	MABS-Beam-Elektrode	MABS beam electrode	Electrodo MABS Beam
80-181-13-04	2	MABS-Lanzetten-Elektrode	MABS lancet electrode	Electrodo de lanceta MABS
80-181-15-04	2	MABS-Nadel-Elektrode	MABS needle electrode	Electrodo de aguja MABS
80-344-09-04	1	PCS-DuoSafe-Einmal-Neutralelektroden, VE = 50 Stck.	PCS disposable neutral electrode, SU = 50/pack	Placas neutras desechables PCS DuoSafe UV = 50 piezas
80-294-44-04	1	Anschlusskabel für Neutralelektroden	Connection cable for neutral electrodes	Cable de conexión para placas neutras
80-924-16-04	2	Bipolare Pinzette, gerade, stumpf	Bipolar forceps, straight, blunt	Pinzas bipolares, rectas, romas
80-287-89-04	4	Anschlusskabel für bipolare Instrumente	Connection cable for bipolar instruments	Cable de conexión para instrumentos bipolares
		<b>Optional:</b>	<b>Optional:</b>	<b>Opcional:</b>
80-975-23-04	2	marClamp® IQ, gebogene Version, 23 cm	marClamp® IQ, curved version, 23 cm	marClamp® IQ, versión curva, 23 cm
80-570-23-04	2	marCut®, 23 cm	marCut®, 23 cm	marCut®, 23 cm



<b>80-042-11-04</b>		<b>Lot d'accessoires pour maXium® m, composé de:</b>	<b>Serie di accessori per maXium® m, composta di:</b>
80-181-52-04	1	Décompresseur (D, A, ...)	Riduttore di pressione (D, A, ...)
80-830-01-04	1	Interrupteur à pédale double avec mode SWAP	Interruttore a pedale doppio con modo SWAP
80-830-02-04	1	Interrupteur à une pédale	Interruttore monopedale,
80-260-50-04	1	Câble de compensation de potentiel	Cavo per collegamento equipotenziale
80-181-02-04	2	Manche MABS pour applicateurs rigides	Manipolo MABS per applicatori rigidi
80-181-10-04	2	Electrode MABS Beam	Elettrodo MABS Beam
80-181-13-04	2	Electrode couteaux MABS	Elettrodo a lancetta MABS
80-181-15-04	2	Electrode aiguille MABS	Elettrodo ad ago MABS
80-344-09-04	1	Electrodes neutres à usage unique type PCS DuoSafe UC = 50 pièces	Elettrodi neutri PCS DuoSafe monouso UV = 50 pezzi
80-294-40-04	1	Câble de raccordement pour électrodes neutres	Cavo di connessione per elettrodi neutri
80-924-16-04	2	Pinces bipolaires, droites, mousses	Pinze bipolari, strette, smusse
80-287-33-04	4	Câble de raccordement pour instruments bipolaires	Cavo di connessione per strumenti bipolari
		<b>En option:</b>	<b>Opzioni:</b>
80-975-23-04	2	marClamp® IQ, version courbe, 23 cm	marClamp® IQ, versione curva, 23 cm
80-570-23-04	2	marCut®, 23 cm	marCut®, 23 cm

<b>80-042-21-04</b>		<b>Lot d'accessoires pour maXium® i, composé de:</b>	<b>Serie di accessori per maXium® i, composta di:</b>
80-181-52-04	1	Décompresseur (NL, DK, ...)	Riduttore di pressione (NL, DK, ...)
80-830-01-04	1	Interrupteur à pédale double avec mode SWAP	Interruttore a pedale doppio con modo SWAP
80-830-02-04	1	Interrupteur à une pédale	Interruttore monopedale
80-260-50-04	1	Câble de compensation de potentiel	Cavo per collegamento equipotenziale
80-181-02-04	2	Manche MABS pour applicateurs rigides	Manipolo MABS per applicatori rigidi
80-181-10-04	2	Electrode MABS Beam	Elettrodo MABS Beam
80-181-13-04	2	Electrode couteaux MABS	Elettrodo a lancetta MABS
80-181-15-04	2	Electrode aiguille MABS	Elettrodo ad ago MABS
80-344-09-04	1	Electrodes neutres à usage unique type PCS DuoSafe UC = 50 pièces	Elettrodi neutri PCS DuoSafe monouso UV = 50 pezzi
80-294-44-04	1	Câble de raccordement pour électrodes neutres	Cavo di connessione per elettrodi neutri
80-924-16-04	2	Pinces bipolaires, droites, mousses	Pinze bipolari, strette, smusse
80-287-89-04	4	Câble de raccordement pour instruments bipolaires	Cavo di connessione per strumenti bipolari
		<b>En option:</b>	<b>Opzioni:</b>
80-975-23-04	2	marClamp® IQ, version courbe, 23 cm	marClamp® IQ, versione curva, 23 cm
80-570-23-04	2	marCut®, 23 cm	marCut®, 23 cm

maXium®-Beamer-Zubehörsätze für die Offene Chirurgie  
 maXium® Beamer accessory sets for open surgery  
 Juegos de accesorios maXium® Beamer para la cirugía abierta  
 Jeux d'accessoires maXium® Beamer pour la chirurgie ouverte  
 Serie di accessori maXium® Beamer per la chirurgia aperta

80-042-41-04		Satz Zubehör für maXium® e, bestehend aus:	Accessory set for maXium® e, consisting of:	Juego de accesorios para maXium® e, compuesto de:
80-181-55-04	1	Druckminderer (UK ...)	Pressure reducer (UK ...)	Manorreductor (UK ...)
80-830-01-04	1	SWAP-Mode-Doppelpedalfußschalter	SWAP mode double-pedal foot switch	Interrupor de pie de doble pedal con modo SWAP
80-830-02-04	1	Einpedalfußschalter	Single-pedal foot switch	Interrupor de pie de un pedal
80-260-50-04	1	Potentialausgleichskabel	Potential equalization cable	Cable de conexión equipotencial
80-181-02-04	2	MABS-Handgriff für starre Applikatoren	MABS handle for rigid applicators	Mango MABS para aplicadores rígidos
80-181-10-04	2	MABS-Beam-Elektrode	MABS beam electrode	Electrodo MABS Beam
80-181-13-04	2	MABS-Lanzetten-Elektrode	MABS lancet electrode	Electrodo de lanceta MABS
80-181-15-04	2	MABS-Nadel-Elektrode	MABS needle electrode	Electrodo de aguja MABS
80-344-09-04	1	PCS-DuoSafe-Einmal-Neutralelektroden, VE = 50 Stck.	PCS disposable neutral electrode, SU = 50/pack	Placas neutras desechables PCS DuoSafe UV = 50 piezas
80-294-40-04	1	Anschlusskabel für Neutralelektroden	Connection cable for neutral electrodes	Cable de conexión para placas neutras
80-924-16-04	2	Bipolare Pinzette, gerade, stumpf	Bipolar forceps, straight, blunt	Pinzas bipolares, rectas, romas
80-287-89-04	4	Anschlusskabel für bipolare Instrumente	Connection cable for bipolar instruments	Cable de conexión para instrumentos bipolares
		<b>Optional:</b>	<b>Optional:</b>	<b>Opcional:</b>
80-975-23-04	2	marClamp® IQ, gebogene Version, 23 cm	marClamp® IQ, curved version, 23 cm	marClamp® IQ, versión curva, 23 cm
80-570-23-04	2	marCut®, 23 cm	marCut®, 23 cm	marCut®, 23 cm



<b>80-042-41-04</b>		<b>Lot d'accessoires pour maXium® e, composé de:</b>	<b>Serie di accessori per maXium® e, composta di:</b>
80-181-52-04	1	Décompresseur (UK ...)	Riduttore di pressione (UK ...)
80-830-01-04	1	Interrupteur à pédale double avec mode SWAP	Interruttore a pedale doppio con modo SWAP
80-830-02-04	1	Interrupteur à une pédale	Interruttore monopedale
80-260-50-04	1	Câble de compensation de potentiel	Cavo per collegamento equipotenziale
80-181-02-04	2	Manche MABS pour applicateurs rigides	Manipolo MABS per applicatori rigidi
80-181-10-04	2	Electrode MABS Beam	Elettrodo MABS Beam
80-181-13-04	2	Electrode couteaux MABS	Elettrodo a lancetta MABS
80-181-15-04	2	Electrode aiguille MABS	Elettrodo ad ago MABS
80-344-09-04	1	Electrodes neutres à usage unique type PCS DuoSafe UC = 50 pièces	Elettrodi neutri PCS DuoSafe monouso UV = 50 pezzi
80-294-40-04	1	Câble de raccordement pour électrodes neutres	Cavo di connessione per elettrodi neutri
80-924-16-04	2	Pinces bipolaires, droites, mousses	Pinze bipolari, strette, smusse
80-287-89-04	4	Câble de raccordement pour instruments bipolaires	Cavo di connessione per strumenti bipolari
		<b>En option:</b>	<b>Opzioni:</b>
80-975-23-04	2	marClamp® IQ, version courbe, 23 cm	marClamp® IQ, versione curva, 23 cm
80-570-23-04	2	marCut®, 23 cm	marCut®, 23 cm

maXium®-Beamer-Zubehörsätze für die Endoskopische Chirurgie  
maXium® Beamer accessory sets for endoscopic surgery  
Juegos de accesorios maXium® Beamer para la cirugía endoscópica  
Jeux d'accessoires maXium® Beamer pour la chirurgie endoscopique  
Serie di accessori maXium® Beamer per la chirurgia endoscopica

80-042-12-04		Satz Zubehör für maXium® m, bestehend aus:	Accessory set for maXium® m, consisting of:	Juego de accesorios para maXium® m, compuesto de:
80-181-52-04	1	Druckminderer (D, A, ...)	Pressure reducer (D, A, ...)	Manorreductor (D, A, ...)
80-830-02-04	1	Einpedalfußschalter	Single-pedal foot switch	Interruptor de pie de un pedal
80-260-50-04	1	Potentialausgleichskabel	Potential equalization cable	Cable de conexión equipotencial
80-181-30-04	2	MABS-Anschlussleitung für flexible Sonden	MABS connection cable for flexible probes	Línea de conexión MABS para sondas flexibles
80-181-24-04	2	GIT-Sonde ( Ø 3,2 mm)	GIT probe ( Ø 3.2 mm)	Sonda GIT ( Ø 3,2 mm)
80-181-23-04	2	GIT-Sonde ( Ø 2,3 mm)	GIT probe ( Ø 2.3 mm)	Sonda GIT ( Ø 2,3 mm)
80-181-25-04	2	TBS-Sonde ( Ø 1,5 mm)	TBS probe ( Ø 1.5 mm)	Sonda TBS ( Ø 1,5 mm)
80-344-09-04	1	PCS-DuoSafe-Einmal-Neutralelektroden, VE = 50 Stck.	Disposable DuoSafe neutral electrodes, SU = 50/pack	Placas neutras desechables PCS DuoSafe, UV = 50 piezas
80-294-40-04	1	Anschlusskabel für Neutralelektroden	Connection cable for neutral electrodes	Cable de conexión para placas neutras
80-924-16-04	2	Bipolare Pinzette, gerade, stumpf	Bipolar forceps, straight, blunt	Pinzas bipolares, rectas, romas
80-287-33-04	4	Anschlusskabel für bipolare Instrumente	Connection cable for bipolar instruments	Cable de conexión para instrumentos bipolares
80-289-40-04	2	Olympus-Anschlusskabel	Olympus connection cable	Cable de conexión Olympus

80-042-22-04		Satz Zubehör für maXium® i, bestehend aus:	Accessory set for maXium® i, consisting of:	Juego de accesorios para maXium® i, compuesto de:
80-181-53-04	1	Druckminderer (NL, DK, ...)	Pressure reducer (NL, DK, ...)	Manorreductor (NL, DK, ...)
80-830-02-04	1	Einpedalfußschalter	Single-pedal foot switch	Interruptor de pie de un pedal
80-260-50-04	1	Potentialausgleichskabel	Potential equalization cable	Cable de conexión equipotencial
80-181-30-04	2	MABS-Anschlussleitung für flexible Sonden	MABS connection cable for flexible probes	Línea de conexión MABS para sondas flexibles
80-181-24-04	2	GIT-Sonde ( Ø 3,2 mm)	GIT probe ( Ø 3.2 mm)	Sonda GIT ( Ø 3,2 mm)
80-181-23-04	2	GIT-Sonde ( Ø 2,3 mm)	GIT probe ( Ø 2.3 mm)	Sonda GIT ( Ø 2,3 mm)
80-181-25-04	2	TBS-Sonde ( Ø 1,5 mm)	TBS probe ( Ø 1.5 mm)	Sonda TBS ( Ø 1,5 mm)
80-344-09-04	1	PCS-DuoSafe-Einmal-Neutralelektroden, VE = 50 Stck.	Disposable DuoSafe neutral electrodes SU = 50/pack	Placas neutras desechables PCS DuoSafe UV = 50 piezas
80-294-44-04	1	Anschlusskabel für Neutralelektroden	Connection cable for neutral electrodes	Cable de conexión para placas neutras
80-924-16-04	2	Bipolare Pinzette, gerade, stumpf	Bipolar forceps, straight, blunt	Pinzas bipolares, rectas, romas
80-287-89-04	4	Anschlusskabel für bipolare Instrumente	Connection cable for bipolar instruments	Cable de conexión para instrumentos bipolares
80-289-40-04	2	Olympus-Anschlusskabel	Olympus connection cable	Cable de conexión Olympus

80-042-42-04		Satz Zubehör für maXium® e, bestehend aus:	Accessory set for maXium® e, consisting of:	Juego de accesorios para maXium® e, compuesto de:
80-181-55-04	1	Druckminderer (UK...)	Pressure reducer (UK...)	Manorreductor (UK...)
80-830-02-04	1	Einpedalfußschalter	Single-pedal foot switch	Interruptor de pie de un pedal
80-260-50-04	1	Potentialausgleichskabel	Potential equalization cable	Cable de conexión equipotencial
80-181-30-04	2	MABS-Anschlussleitung für flexible Sonden	MABS connection cable for flexible probes	Línea de conexión MABS para sondas flexibles
80-181-24-04	2	GIT-Sonde ( Ø 3,2 mm)	GIT probe ( Ø 3.2 mm)	Sonda GIT ( Ø 3,2 mm)
80-181-23-04	2	GIT-Sonde ( Ø 2,3 mm)	GIT probe ( Ø 2.3 mm)	Sonda GIT ( Ø 2,3 mm)
80-181-25-04	2	TBS-Sonde ( Ø 1,5 mm)	TBS probe ( Ø 1.5 mm)	Sonda TBS ( Ø 1,5 mm)
80-344-09-04	1	PCS-DuoSafe-Einmal-Neutralelektroden, VE = 50 Stck.	Disposable DuoSafe neutral electrodes SU = 50/pack	Placas neutras desechables PCS DuoSafe UV = 50 piezas
80-294-40-04	1	Anschlusskabel für Neutralelektroden	Connection cable for neutral electrodes	Cable de conexión para placas neutras
80-924-16-04	2	Bipolare Pinzette, gerade, stumpf	Bipolar forceps, straight, blunt	Pinzas bipolares, rectas, romas
80-287-89-04	4	Anschlusskabel für bipolare Instrumente	Connection cable for bipolar instruments	Cable de conexión para instrumentos bipolares
80-289-40-04	2	Olympus-Anschlusskabel	Olympus connection cable	Cable de conexión Olympus



<b>80-042-12-04</b>		<b>Lot d'accessoires pour maXium® m, composé de:</b>	<b>Serie di accessori per maXium® m, composta di:</b>
80-181-52-04	1	Décompresseur (D, A, ...)	Riduttore di pressione (D, A, ...)
80-830-02-04	1	Interrupteur à une pédale	Interruttore monopedale,
80-260-50-04	1	Câble de compensation de potentiel	Cavo per collegamento equipotenziale
80-181-30-04	2	Conduite raccord MABS pour sondes flexibles	Cavo di collegamento MABS per sonde flessibili
80-181-24-04	2	Sonde GIT ( Ø 3,2 mm)	Sonda GIT ( Ø 3,2 mm)
80-181-23-04	2	Sonde GIT ( Ø 2,3 mm)	Sonda GIT ( Ø 2,3 mm)
80-181-25-04	2	Sonde TBS ( Ø 1,5 mm)	Sonda TBS ( Ø 1,5 mm)
80-344-09-04	1	Electrodes neutres à usage unique type PCS DuoSafe, UC = 50 pièces	Elettrodi neutri PCS DuoSafe monouso UV = 50 pezzi
80-294-40-04	1	Câble de raccordement pour électrodes neutres	Cavo di connessione per elettrodi neutri
80-924-16-04	2	Pinces bipolaires, droites, mousses	Pinze bipolari, strette, smusse
80-287-33-04	4	Câble de raccordement pour instruments bipolaires	Cavo di connessione per strumenti bipolari
80-289-40-04	2	Câble de raccordement Olympus	Cavo di connessione Olympus

<b>80-042-22-04</b>		<b>Lot d'accessoires pour maXium® i, composé de:</b>	<b>Serie di accessori per maXium® i, composta di:</b>
80-181-53-04	1	Décompresseur (NL, DK, ...)	Riduttore di pressione (NL, DK, ...)
80-830-02-04	1	Interrupteur à une pédale	Interruttore monopedale,
80-260-50-04	1	Câble de compensation de potentiel	Cavo per collegamento equipotenziale
80-181-30-04	2	Conduite raccord MABS pour sondes flexibles	Cavo di collegamento MABS per sonde flessibili
80-181-24-04	2	Sonde GIT ( Ø 3,2 mm)	Sonda GIT ( Ø 3,2 mm)
80-181-23-04	2	Sonde GIT ( Ø 2,3 mm)	Sonda GIT ( Ø 2,3 mm)
80-181-25-04	2	Sonde TBS ( Ø 1,5 mm)	Sonda TBS ( Ø 1,5 mm)
80-344-09-04	1	Electrodes neutres à usage unique type PCS DuoSafe UC = 50 pièces	Elettrodi neutri PCS DuoSafe monouso UV = 50 pezzi
80-294-44-04	1	Câble de raccordement pour électrodes neutres	Cavo di connessione per elettrodi neutri
80-924-16-04	2	Pinces bipolaires, droites, mousses	Pinze bipolari, strette, smusse
80-287-89-04	4	Câble de raccordement pour instruments bipolaires	Cavo di connessione per strumenti bipolari
80-289-40-04	2	Câble de raccordement Olympus	Cavo di connessione Olympus



<b>80-042-42-04</b>		<b>Lot d'accessoires pour maXium® e, composé de:</b>	<b>Serie di accessori per maXium® e, composta di:</b>
80-181-55-04	1	Décompresseur (UK...)	Riduttore di pressione (UK...)
80-830-02-04	1	Interrupteur à une pédale	Interruttore monopedale,
80-260-50-04	1	Câble de compensation de potentiel	Cavo per collegamento equipotenziale
80-181-30-04	2	Conduite raccord MABS pour sondes flexibles	Cavo di collegamento MABS per sonde flessibili
80-181-24-04	2	Sonde GIT ( Ø 3,2 mm)	Sonda GIT ( Ø 3,2 mm)
80-181-23-04	2	Sonde GIT ( Ø 2,3 mm)	Sonda GIT ( Ø 2,3 mm)
80-181-25-04	2	Sonde TBS ( Ø 1,5 mm)	Sonda TBS ( Ø 1,5 mm)
80-344-09-04	1	Electrodes neutres à usage unique type PCS DuoSafe UC = 50 pièces	Elettrodi neutri PCS DuoSafe monouso UV = 50 pezzi
80-294-40-04	1	Câble de raccordement pour électrodes neutres	Cavo di connessione per elettrodi neutri
80-924-16-04	2	Pinces bipolaires, droites, mousses	Pinze bipolari, strette, smusse
80-287-89-04	4	Câble de raccordement pour instruments bipolaires	Cavo di connessione per strumenti bipolari
80-289-40-04	2	Câble de raccordement Olympus	Cavo di connessione Olympus

80-107-00-04		Zubehörsatz, Handaktivierung für MD 62, bestehend aus:	Accessory set for MD 62 for hand switch operation, consisting of:	Juego de accesorios MD 62 con interruptor digital, compuesto de:
80-214-13-04	1	smartPen Elektroden-Handgriff mit einer Taste für 1,6-mm-Elektroden, mit KLS Martin-Stecker	smartPen electrode handle with one pushbutton, for 1.6-mm electrodes, with KLS Martin plug	Mango porta-electrodos smartPen con una tecla, para electrodos 1,6 mm, con clavija de KLS Martin
80-444-08-01	1	Elektroden-Ständer für 8 Dentalelektroden	Electrode box for 8 dental electrodes	Caja para 8 electrodos dentales
80-461-01-04	1	Nadelelektrode	Needle electrode	Electrodo de aguja
80-461-02-04	1	Nadelelektrode, 45° abgewinkelt	Needle electrode, 45° angled	Electrodo de aguja, acodado 45°
80-461-12-04	1	Drahtschlingenelektrode Ø 5 mm	Wire loop electrode Ø 5 mm	Electrodo de asa de alambre Ø 5 mm
80-461-14-04	1	Drahtschlingenelektrode, rhombusförmig	Wire loop electrode, rhombic	Electrodo de asa de alambre romboidal
80-461-15-04	1	Drahtschlingenelektrode, länglich, Schaft 45° abgewinkelt	Wire loop electrode, elongated, shaft 45° angled	Electrodo de asa de alambre oblonga, vástago acodado 45°
80-461-31-04	1	Koagulations-Nadelelektrode	Coagulation needle electrode	Electrodo de aguja, para la coagulación
80-461-34-04	1	Koagulations-Kugelelektrode	Coagulation ball electrode	Electrodo de bola, para la coagulación
80-310-04-04	1	Handzylinder-Neutralelektrode mit 4 m Kabel	Hand cylinder neutral electrode with connection cable of 4 m	Placa neutra en forma de cilindro con cable de conexión de 4 m
80-505-00-04	1	Reinigungspad für Elektroden, steril verpackt, VE = 100 Stck.	Cleaning pad for electrodes, sterile packed, SU = 100/pack	Almohadilla de limpieza para electrodos, embalado estéril, UV = 100 piezas

80-106-01-04		Zubehörsatz, Fußaktivierung für MD 62, bestehend aus:	Accessory set for MD 62 for foot switch operation, consisting of:	Juego de accesorios MD 62 con interruptor de pedal, compuesto de:
80-214-12-04	1	smartPen Elektroden-Handgriff ohne Tasten für 1,6-mm-Elektroden, mit KLS Martin-Stecker	smartPen electrode handle without pushbutton, for 1.6-mm electrodes, with KLS Martin plug	Mango porta-electrodos smartPen sin teclas, para electrodos 1,6 mm, con clavija de KLS Martin
80-444-08-01	1	Elektroden-Ständer für 8 Dentalelektroden	Electrode box for 8 dental electrodes	Caja para 8 electrodos dentales
80-461-01-04	1	Nadelelektrode	Needle electrode	Electrodo de aguja
80-461-02-04	1	Nadelelektrode, 45° abgewinkelt	Needle electrode, 45° angled	Electrodo de aguja, acodado 45°
80-461-12-04	1	Drahtschlingenelektrode Ø 5 mm	Wire loop electrode Ø 5 mm	Electrodo de asa de alambre Ø 5 mm
80-461-14-04	1	Drahtschlingenelektrode, rhombusförmig	Wire loop electrode, rhombic	Electrodo de asa de alambre romboidal
80-461-15-04	1	Drahtschlingenelektrode, länglich, Schaft 45° abgewinkelt	Wire loop electrode, elongated, shaft 45° angled	Electrodo de asa de alambre oblonga, vástago acodado 45°
80-461-31-04	1	Koagulations-Nadelelektrode	Coagulation needle electrode	Electrodo de aguja, para la coagulación
80-461-34-04	1	Koagulations-Kugelelektrode	Coagulation ball electrode	Electrodo de bola, para la coagulación
80-812-10-04	1	Einpedal-Fußschalter, Air, 3 m Kabel	Single-pedal foot switch, Air, with connection cable of 3 m	Interruptor de pedal, Air, cable de conexión de 3 m
80-310-04-04	1	Handzylinder-Neutralelektrode mit 4 m Kabel	Hand cylinder neutral electrode with connection cable of 4 m	Placa neutra en forma de cilindro con cable de conexión de 4 m
80-505-00-04	1	Reinigungspad für Elektroden, steril verpackt, VE = 100 Stck.	Cleaning pad for electrodes, sterile packed, SU = 100/pack	Almohadilla de limpieza para electrodos, embalado estéril, UV = 100 piezas





<b>80-107-00-04</b>		<b>Lot d'accessoires MD 62 pour commande digitale, composé de:</b>	<b>Serie di accessori standard MD 62, per attivazione a mano, composta di:</b>
80-214-13-04	1	Manche porte-électrode smartPen avec un interrupteur digital, pour electrodes de 1,6 mm, avec fiche de KLS Martin	Manico portaelettrodi smartPen con un tasto, per elettrodi da 4 mm, con spina da KLS Martin
80-444-08-01	1	Boîte pour 8 électrodes dentaires	Supporto per 8 elettrodi dentali in scatola
80-461-01-04	1	Electrode aiguille	Elettrodo ad ago
80-461-02-04	1	Electrode aiguille, coudée en 45°	Elettrodo ad ago, angolo 45°
80-461-12-04	1	Electrode anse Ø 5 mm	Elettrodo ad ansa Ø 5 mm
80-461-14-04	1	Electrode anse, romboïdale	Elettrodo ad ansa a forma di rombo
80-461-15-04	1	Electrode anse, forme allongée, tige coudée en 45°	Elettrodo ad ansa recta, asta curva a 45°
80-461-31-04	1	Electrode aiguille pour la coagulation	Elettrodo ad ago per coagulazione
80-461-34-04	1	Electrode boule pour la coagulation	Elettrodo a sfera per coagulazione
80-310-04-04	1	Electrode neutre en forme de cylindre avec câble de raccordement de 4 m	Elettrodo neutro a forma cilindrica con cavo di connessione da 4 m
80-505-00-04	1	Tampon de nettoyage pour électrodes, emballage stérile, UC = 100 pièces	Tampone di pulizia per elettrodi, imballaggio sterile, UV = 100 pezzi

<b>80-106-01-04</b>		<b>Lot d'accessoires MD 62 pour commande par pédale, composé de:</b>	<b>Serie di accessori standard MD 62, per attivazione a pedale, composta di:</b>
80-214-12-04	1	Manche porte-électrode smartPen sans interrupteur, pour electrodes de 1,6 mm, avec fiche de KLS Martin	Manico portaelettrodi smartPen senza tasti, per elettrodi da 1,6mm, con spina da KLS Martin
80-444-08-01	1	Boîte pour 8 électrodes dentaires	Supporto per 8 elettrodi dentali in scatola
80-461-01-04	1	Electrode aiguille	Elettrodo ad ago
80-461-02-04	1	Electrode aiguille	Elettrodo ad ago
80-461-12-04	1	Electrode anse	Elettrodo ad ansa
80-461-14-04	1	Electrode anse	Elettrodo ad ansa
80-461-15-04	1	Electrode anse	Elettrodo ad ansa
80-461-31-04	1	Electrode aiguille pour la coagulation	Elettrodo ad ago per coagulazione
80-461-34-04	1	Electrode boule pour la coagulation	Elettrodo a sfera per coagulazione
80-812-10-04	1	Interrupteur à pédale, Air, avec câble de raccordement de 3 m	Interruttore con 1 pedale, Air, con cavo di connessione di 3 m
80-310-04-04	1	Electrode neutre en forme de cylindre avec câble de raccordement de 4 m	Elettrodo neutro a forma cilindrica con cavo di connessione da 4 m
80-505-00-04	1	Tampon de nettoyage pour électrodes, emballage stérile, UC = 100 pièces	Tampone di pulizia per elettrodi, imballaggio sterile, UV = 100 pezzi

<b>80-108-03-04</b>		<b>Großer Zubehörsatz monopolar, Handaktivierung für miniCutter, bestehend aus:</b>	<b>Accessory set monopolar for miniCutter for hand switch operation, large, consisting of:</b>	<b>Juego de accesorios monopolares miniCutter con interruptor digital, grande, compuesto de:</b>
80-217-05-04	1	smartPen Elektroden-Handgriff mit einer Taste für 4-mm-Elektroden, mit KLS Martin-Stecker	smartPen electrode handle with one pushbutton, for 4-mm electrodes, with KLS Martin plug	Mango porta-electrodos smartPen con una tecla, para electrodos 4 mm, con clavija de KLS Martin
80-332-03-04	1	Gummi-Neutralelektrode 8 x 16 cm, 4 m Kabel	Rubber neutral electrode, 8 x 16 cm, with connection cable of 4 m	Placa neutra de goma, 8 x 16 cm, cable de conexión de 4 m
80-370-50-04	1	Gummibinde, gelocht, 50 cm	Rubber band, with holes, 50 cm	Cinta de goma, perforada, 50 cm
80-371-01-04	1	Knopf für Gummibinde	Button for rubber band	Botón para la cinta de goma
80-408-00-04	1	Elektroden-Ständer für 8 Elektroden	Electrode box for 8 electrodes	Caja para 8 electrodos
80-505-00-04	1	Reinigungspad für Elektroden, steril verpackt, VE = 100 Stck.	Cleaning pad for electrodes, sterile packed, SU = 100/pack	Almohadilla de limpieza para electrodos, embalado estéril, UV = 100 piezas
80-510-04-04	1	Lanzettelektrode, gerade	Lancet electrode, straight	Electrodo de lanceta, recto
80-515-04-04	1	Messerelektrode	Knife electrode	Electrodo de cuchillo
80-520-04-04	1	Nadelelektrode	Needle electrode	Electrodo de aguja
80-540-04-04	1	Drahtschlingenelektrode, Ø 5 mm	Wire loop electrode, Ø 5 mm	Electrodo de asa de alambre, Ø 5 mm
80-542-04-04	1	Drahtschlingenelektrode, Ø 10 mm	Wire loop electrode, Ø 10 mm	Electrodo de asa de alambre, Ø 10 mm
80-560-04-04	1	Kugelelektrode, Ø 2 mm	Ball electrode, Ø 2 mm	Electrodo de bola, Ø 2 mm
80-562-04-04	1	Kugelelektrode, Ø 4 mm	Ball electrode, Ø 4 mm	Electrodo de bola, Ø 4 mm

<b>80-108-04-04</b>		<b>Großer Zubehörsatz monopolar, Fußaktivierung für miniCutter, bestehend aus:</b>	<b>Accessory set monopolar for miniCutter for foot switch operation, large, consisting of:</b>	<b>Juego de accesorios monopolares miniCutter con interruptor de pedal, grande, compuesto de:</b>
80-220-02-04	1	smartPen Elektroden-Handgriff ohne Tasten für 4-mm-Elektroden, mit KLS Martin-Stecker	smartPen electrode handle without pushbutton, for 4-mm electrodes, with KLS Martin plug	Mango porta-electrodos smartPen sin tecla, para electrodos 4 mm, con clavija de KLS Martin
80-332-03-04	1	Gummi-Neutralelektrode 8 x 16 cm, 4 m Kabel	Rubber neutral electrode, 8 x 16 cm, with connection cable of 4 m	Placa neutra de goma, 8 x 16 cm, cable de conexión de 4 m
80-370-50-04	1	Gummibinde, gelocht, 50 cm	Rubber band, with holes, 50 cm	Cinta de goma, perforada, 50 cm
80-371-01-04	1	Knopf für Gummibinde	Button for rubber band	Botón para la cinta de goma
80-408-00-01	1	Elektroden-Ständer für 8 Elektroden	Electrode box for 8 electrodes	Caja para 8 electrodos
80-505-00-04	1	Reinigungspad für Elektroden, steril verpackt, VE = 100 Stck.	Cleaning pad for electrodes, sterile packed, SU = 100/pack	Almohadilla de limpieza para electrodos, embalado estéril, UV = 100 piezas
80-510-04-04	1	Lanzettelektrode, gerade	Lancet electrode, straight	Electrodo de lanceta, recto
80-515-04-04	1	Messerelektrode	Knife electrode	Electrodo de cuchillo
80-520-04-04	1	Nadelelektrode	Needle electrode	Electrodo de aguja
80-540-04-04	1	Drahtschlingenelektrode, Ø 5 mm	Wire loop electrode, Ø 5 mm	Electrodo de asa de alambre, Ø 5 mm
80-542-04-04	1	Drahtschlingenelektrode, Ø 10 mm	Wire loop electrode, Ø 10 mm	Electrodo de asa de alambre Ø 10 mm
80-560-04-04	1	Kugelelektrode, Ø 2 mm	Ball electrode, Ø 2 mm	Electrodo de bola, Ø 2 mm
80-562-04-04	1	Kugelelektrode, Ø 4 mm	Ball electrode, Ø 4 mm	Electrodo de bola, Ø 4 mm
80-811-50-04	1	Einpedal-Fußschalter	Single-pedal foot switch	Interruptor de pie de un pedal

<b>80-108-05-04</b>		<b>Kleiner Zubehörsatz monopolar, Handaktivierung für miniCutter, bestehend aus:</b>	<b>Accessory set monopolar for miniCutter for hand switch operation, small, consisting of:</b>	<b>Juego de accesorios monopolares miniCutter con interruptor digital, pequeño, compuesto de:</b>
80-217-05-04	1	smartPen Elektroden-Handgriff mit einer Taste für 4-mm-Elektroden, mit KLS Martin-Stecker	smartPen electrode handle with one pushbutton, for 4-mm electrodes, with KLS Martin plug	Mango porta-electrodos smartPen con una tecla, para electrodos 4 mm, con clavija de KLS Martin
80-332-03-04	1	Gummi-Neutralelektrode 8 x 16 cm, 4 m Kabel	Rubber neutral electrode, 8 x 16 cm, with connection cable of 4 m	placa neutra de goma, 8 x 16 cm, cable de conexión de 4 m
80-372-00-04	1	Textilband mit Klettverschluss, 90 cm	Textile band with velcro strap, 90 cm	Tira auto-adhesiva, 90 cm
80-505-00-04	1	Reinigungspad für Elektroden, steril verpackt, VE = 100 Stck.	Cleaning pad for electrodes, sterile packed, SU = 100/pack	Almohadilla de limpieza para electrodos, embalado estéril, UV = 100 piezas
80-511-04-04	1	Lanzettelektrode, abgewinkelt	Lancet electrode, angled	Electrodo de lanceta, acodado
80-515-04-04	1	Messerelektrode	Knife electrode	Electrodo de cuchillo
80-520-04-04	1	Nadelelektrode	Needle electrode	Electrodo de aguja
80-562-04-04	1	Kugelelektrode, Ø 4 mm	Ball electrode, Ø 4 mm	Electrodo de bola, Ø 4 mm



<b>80-108-03-04</b>		<b>Grand lot d'accessoires monopolaires miniCutter pour commande digitale, composé de:</b>	<b>Serie grande di accessori monopolari standard miniCutter, per attivazione a mano, composta di:</b>
80-217-05-04	1	Manche porte-électrode smartPen avec un interrupteur digital, pour electrodes de 4 mm, avec fiche de KLS Martin	Manico portaelettrodi smartPen con una tasto, per elettrodi da 4 mm, con spina da KLS Martin
80-332-03-04	1	Electrode neutre en caoutchouc, 8 x 16 cm, avec câble de raccordement de 4 m	Elettrodo neutro di gomma, 8 x 16 cm, cavo di connessione di 4 m
80-370-50-04	1	Bande caoutchouc, perforée, 50 cm	Nastro di gomma, perforato, 50 cm
80-371-01-04	1	Bouton pour bande caoutchouc	Bottone per nastro di gomma
80-408-00-04	1	Boîte pour 8 électrodes	Supporto per 8 elettrodi in scatola
80-505-00-04	1	Tampon de nettoyage pour électrodes, emballage stérile, UC = 100 pièces	Tampone di pulizia per elettrodi, imballaggio sterile, UV = 100 pezzi
80-510-04-04	1	Electrode lancette, droite	Elettrodo a lancetta, retto
80-515-04-04	1	Electrode couteau	Elettrodo a bisturi
80-520-04-04	1	Electrode aiguille	Elettrodo ad ago
80-540-04-04	1	Electrode anse en fil, Ø 5 mm	Elettrodo ad ansa, Ø 5 mm
80-542-04-04	1	Electrode anse en fil, Ø 10 mm	Elettrodo ad ansa, Ø 10 mm
80-560-04-04	1	Electrode boule, Ø 2 mm	Elettrodo a sfera, Ø 2 mm
80-562-04-04	1	Electrode boule, Ø 4 mm	Elettrodo a sfera, Ø 4 mm

<b>80-108-04-04</b>		<b>Grand lot d'accessoires monopolaires miniCutter pour commande par pédale, composé de:</b>	<b>Serie grande di accessori monopolari standard miniCutter, per attivazione a pedale, composta di:</b>
80-220-02-04	1	Manche porte-électrode smartPen sans interrupteur, pour electrodes de 4 mm, avec fiche de KLS Martin	Manico portaelettrodi smartPen senza tasti, per elettrodi da 4 mm, con spina da KLS Martin
80-332-03-04	1	Electrode neutre en caoutchouc, 8 x 16 cm, avec câble de raccordement de 4 m	Elettrodo neutro di gomma, 8 x 16 cm, cavo di connessione di 4 m
80-370-50-04	1	Bande caoutchouc, perforée, 50 cm	Nastro di gomma, perforato, 50 cm
80-371-01-04	1	Bouton pour bande caoutchouc	Bottone per nastro di gomma
80-408-00-01	1	Boîte pour 8 électrodes	Supporto per 8 elettrodi in scatola
80-505-00-04	1	Tampon de nettoyage pour électrodes, emballage stérile, UC = 100 pièces	Tampone di pulizia per elettrodi, imballaggio sterile, UV = 100 pezzi
80-510-04-04	1	Electrode lancette, droite	Elettrodo a lancetta, retto
80-515-04-04	1	Electrode couteau	Elettrodo a bisturi
80-520-04-04	1	Electrode aiguille	Elettrodo ad ago
80-540-04-04	1	Electrode anse en fil, Ø 5 mm	Elettrodo ad ansa, Ø 5 mm
80-542-04-04	1	Electrode anse en fil, Ø 10 mm	Elettrodo ad ansa, Ø 10 mm
80-560-04-04	1	Electrode boule, Ø 2 mm	Elettrodo a sfera, Ø 2 mm
80-562-04-04	1	Electrode boule, Ø 4 mm	Elettrodo a sfera, Ø 4 mm
80-811-50-04	1	Interrupteur à une pédale	Interruttore monopedale

<b>80-108-05-04</b>		<b>Petit lot d'accessoires monopolaires miniCutter pour commande digitale, composé de:</b>	<b>Serie piccola di accessori monopolari standard miniCutter, per attivazione a mano, composta di:</b>
80-217-05-04	1	Manche porte-électrode smartPen avec un interrupteur digital, pour electrodes de 4 mm, avec fiche de KLS Martin	Manico portaelettrodi smartPen con una tasto, per elettrodi da 4 mm, con spina da KLS Martin
80-332-03-04	1	Electrode neutre en caoutchouc, 8 x 16 cm, avec câble de raccordement de 4 m	Elettrodo neutro di gomma, 8 x 16 cm, cavo di connessione di 4 m
80-372-00-04	1	Bande auto-adhésive, 90 cm	Nastro tessile auto-adesivo, 90 cm
80-505-00-04	1	Tampon de nettoyage pour électrodes, emballage stérile, UC = 100 pièces	Tampone di pulizia per elettrodi, imballaggio sterile, UV = 100 pezzi
80-511-04-04	1	Electrode lancette, coudée	Elettrodo a lancetta, angolato
80-515-04-04	1	Electrode couteau	Elettrodo a bisturi
80-520-04-04	1	Electrode aiguille	Elettrodo ad ago
80-562-04-04	1	Electrode boule, Ø 4 mm	Elettrodo a sfera, Ø 4 mm

<b>80-108-00-04</b>		<b>Großer Zubehörsatz monopolar, Handaktivierung für ME 102, bestehend aus:</b>	<b>Accessory set monopolar for ME 102 for hand switch operation, large, consisting of:</b>	<b>Juego de accesorios monopolares ME 102 con interruptor digital, grande, compuesto de:</b>
80-217-13-04	1	smartPen Elektroden-Handgriff mit zwei Tasten für 4-mm-Elektroden, mit KLS Martin-Stecker	smartPen electrode handle with two pushbuttons, for 4-mm electrodes, with KLS Martin plug	Mango porta-electrodos smartPen con dos teclas, para electrodos 4 mm, con clavija de KLS Martin
80-332-03-04	1	Gummi-Neutralelektrode 8 x 16 cm, 4 m Kabel	Rubber neutral electrode, 8 x 16 cm, with connection cable of 4 m	Placa neutra de goma, 8 x 16 cm, cable de conexión de 4 m
80-370-50-04	1	Gummibinde, gelocht, 50 cm	Rubber band, with holes, 50 cm	Cinta de goma, perforada, 50 cm
80-371-01-04	1	Knopf für Gummibinde	Button for rubber band	Botón para la cinta de goma
80-408-00-04	1	Elektroden-Ständer für 8 Elektroden	Electrode box for 8 electrodes	Caja para 8 electrodos
80-505-00-04	1	Reinigungspad für Elektroden, steril verpackt, VE = 100 Stck.	Cleaning pad for electrodes, sterile packed, SU = 100/pack	Almohadilla de limpieza para electrodos, embalado estéril, UV = 100 piezas
80-510-04-04	1	Lanzettelektrode, gerade	Lancet electrode, straight	Electrodo de lanceta, recto
80-515-04-04	1	Messerelektrode	Knife electrode	Electrodo de cuchillo
80-520-04-04	1	Nadelelektrode	Needle electrode	Electrodo de aguja
80-540-04-04	1	Drahtschlingenelektrode, Ø 5 mm	Wire loop electrode, Ø 5 mm	Electrodo de asa de alambre, Ø 5 mm
80-542-04-04	1	Drahtschlingenelektrode, Ø 10 mm	Wire loop electrode, Ø 10 mm	Electrodo de asa de alambre, Ø 10 mm
80-560-04-04	1	Kugelelektrode, Ø 2 mm	Ball electrode, Ø 2 mm	Electrodo de bola, Ø 2 mm
80-562-04-04	1	Kugelelektrode, Ø 4 mm	Ball electrode, Ø 4 mm	Electrodo de bola, Ø 4 mm

<b>80-108-01-04</b>		<b>Großer Zubehörsatz monopolar, Fußaktivierung für ME 102, bestehend aus:</b>	<b>Accessory set monopolar for ME 102 for foot switch operation, large, consisting of:</b>	<b>Juego de accesorios monopolares ME 102 con interruptor de pedal, grande, compuesto de:</b>
80-220-02-04	1	smartPen Elektroden-Handgriff ohne Tasten für 4-mm-Elektroden, mit KLS Martin-Stecker	smartPen electrode handle without pushbuttons, for 4-mm electrodes, with KLS Martin plug	Mango porta-electrodos smartPen sin teclas, para electrodos 4 mm, con clavija de KLS Martin
80-332-03-04	1	Gummi-Neutralelektrode 8 x 16 cm, 4 m Kabel	Rubber neutral electrode, 8 x 16 cm, with connection cable of 4 m	Placa neutra de goma, 8 x 16 cm, cable de conexión de 4 m
80-370-50-04	1	Gummibinde, gelocht, 50 cm	Rubber band, with holes, 50 cm	Cinta de goma, perforada, 50 cm
80-371-01-04	1	Knopf für Gummibinde	Button for rubber band	Botón para la cinta de goma
80-408-00-01	1	Elektroden-Ständer für 8 Elektroden	Electrode box for 8 electrodes	Caja para 8 electrodos
80-505-00-04	1	Reinigungspad für Elektroden, steril verpackt, VE = 100 Stck.	Cleaning pad for electrodes, sterile packed, SU = 100/pack	Almohadilla de limpieza para electrodos, embalado estéril, UV = 100 piezas
80-510-04-04	1	Lanzettelektrode, gerade	Lancet electrode, straight	Electrodo de lanceta, recto
80-515-04-04	1	Messerelektrode	Knife electrode	Electrodo de cuchillo
80-520-04-04	1	Nadelelektrode	Needle electrode	Electrodo de aguja
80-540-04-04	1	Drahtschlingenelektrode, Ø 5 mm	Wire loop electrode, Ø 5 mm	Electrodo de asa de alambre, Ø 5 mm
80-542-04-04	1	Drahtschlingenelektrode, Ø 10 mm	Wire loop electrode, Ø 10 mm	Electrodo de asa de alambre, Ø 10 mm
80-560-04-04	1	Kugelelektrode, Ø 2 mm	Ball electrode, Ø 2 mm	Electrodo de bola, Ø 2 mm
80-562-04-04	1	Kugelelektrode, Ø 4 mm	Ball electrode, Ø 4 mm	Electrodo de bola, Ø 4 mm
80-824-01-04	1	Doppelpedal-Fußschalter	Double-pedal foot switch	Interruptor de pie de doble pedal

<b>80-108-02-04</b>		<b>Kleiner Zubehörsatz monopolar, Handaktivierung für ME 102, bestehend aus:</b>	<b>Accessory set monopolar for ME 102 for hand switch operation, small, consisting of:</b>	<b>Juego de accesorios monopolares ME 102 con interruptor digital, pequeño, compuesto de:</b>
80-217-05-04	1	smartPen Elektroden-Handgriff mit einer Taste für 4-mm-Elektroden, mit KLS Martin-Stecker	smartPen electrode handle with one pushbutton, for 4-mm electrodes, with KLS Martin plug	Mango porta-electrodos smartPen con una tecla, para electrodos 4 mm, con clavija de KLS Martin
80-332-03-04	1	Gummi-Neutralelektrode 8 x 16 cm, 4 m Kabel	Rubber neutral electrode, 8 x 16 cm, with connection cable of 4 m	Placa neutra de goma, 8 x 16 cm, cable de conexión de 4 m
80-372-00-04	1	Textilband mit Klettverschluss, 90 cm	Textile band with velcro strap, 90 cm	Tira auto-adhesiva, 90 cm
80-505-00-04	1	Reinigungspad für Elektroden, steril verpackt, VE = 100 Stck.	Cleaning pad for electrodes, sterile packed, SU = 100/pack	Almohadilla de limpieza para electrodos, embalado estéril, UV = 100 piezas
80-511-04-04	1	Lanzettelektrode, abgewinkelt	Lancet electrode, angled	Electrodo de lanceta, acodado
80-515-04-04	1	Messerelektrode	Knife electrode	Electrodo de cuchillo
80-520-04-04	1	Nadelelektrode	Needle electrode	Electrodo de aguja
80-562-04-04	1	Kugelelektrode, Ø 4 mm	Ball electrode, Ø 4 mm	Electrodo de bola, Ø 4 mm



<b>80-108-00-04</b>		<b>Grand lot d'accessoires monopolaires ME 102 pour commande digitale, composé de:</b>	<b>Serie grande di accessori monopolari standard ME 102, per attivazione a mano, composta di:</b>
80-217-13-04	1	Manche porte-électrode smartPen avec interrupteur digital double, pour electrodes de 4 mm, avec fiche de KLS Martin	Manico portaelettrodi smartPen con due tasti, per elettrodi da 4 mm, con spina da KLS Martin
80-332-03-04	1	Electrode neutre en caoutchouc, 8 x 16 cm, avec câble de raccordement de 4 m	Elettrodo neutro di gomma, 8 x 16 cm, cavo di connessione di 4 m
80-370-50-04	1	Bande caoutchouc, perforée, 50 cm	Nastro di gomma, perforato, 50 cm
80-371-01-04	1	Bouton pour bande caoutchouc	Bottone per nastro di gomma
80-408-00-04	1	Boîte pour 8 électrodes	Supporto per 8 elettrodi in scatola
80-505-00-04	1	Tampon de nettoyage pour électrodes, emballage stérile	Tampone di pulizia per elettrodi, imballaggio sterile, UV = 100 pezzi
80-510-04-04	1	Electrode lancette, droite	Elettrodo a lancetta, retto
80-515-04-04	1	Electrode couteau	Elettrodo a bisturi
80-520-04-04	1	Electrode aiguille	Elettrodo ad ago
80-540-04-04	1	Electrode anse en fil, Ø 5 mm	Elettrodo ad ansa, Ø 5 mm
80-542-04-04	1	Electrode anse en fil, Ø 0 mm	Elettrodo ad ansa, Ø 10 mm
80-560-04-04	1	Electrode boule, Ø 2 mm	Elettrodo a sfera, Ø 2 mm
80-562-04-04	1	Electrode boule, Ø 4 mm	Elettrodo a sfera, Ø 4 mm

<b>80-108-01-04</b>		<b>Grand lot d'accessoires monopolaires ME 102 pour commande par pédale, composé de:</b>	<b>Serie grande di accessori monopolari standard ME 102, per attivazione a pedale, composta di:</b>
80-220-02-04	1	Manche porte-électrode smartPen sans interrupteur digital double, pour electrodes de 4 mm, avec fiche de KLS Martin	Manico portaelettrodi smartPen senza tasti, per elettrodi da 4 mm, con spina da KLS Martin
80-332-03-04	1	Electrode neutre en caoutchouc, 8 x 16 cm, avec câble de raccordement de 4 m	Elettrodo neutro di gomma, 8 x 16 cm, cavo di connessione di 4 m
80-370-50-04	1	Bande caoutchouc, perforée, 50 cm	Nastro di gomma, perforato, 50 cm
80-371-01-04	1	Bouton pour bande caoutchouc	Bottone per nastro di gomma
80-408-00-01	1	Boîte pour 8 électrodes	Supporto per 8 elettrodi in scatola
80-505-00-04	1	Tampon de nettoyage pour électrodes, emballage stérile	Tampone di pulizia per elettrodi, imballaggio sterile, UV = 100 pezzi
80-510-04-04	1	Electrode lancette, droite	Elettrodo a lancetta, retto
80-515-04-04	1	Electrode couteau	Elettrodo a bisturi
80-520-04-04	1	Electrode aiguille	Elettrodo ad ago
80-540-04-04	1	Electrode anse en fil, Ø 5 mm	Elettrodo ad ansa, Ø 5 mm
80-542-04-04	1	Electrode anse en fil, Ø 10 mm	Elettrodo ad ansa, Ø 10 mm
80-560-04-04	1	Electrode boule, Ø 2 mm	Elettrodo a sfera, Ø 2 mm
80-562-04-04	1	Electrode boule, Ø 4 mm	Elettrodo a sfera, Ø 4 mm
80-823-02-04	1	Interrupteur à pédale double	Interruttore a pedale doppio

<b>80-108-02-04</b>		<b>Petit lot d'accessoires monopolaires ME 102 pour commande digitale, composé de:</b>	<b>Serie piccola di accessori monopolari standard ME 102, per attivazione a mano, composta di:</b>
80-217-05-04	1	Manche porte-électrode smartPen avec un interrupteur digital, pour electrodes de 4 mm, avec fiche de KLS Martin	Manico portaelettrodi smartPen con una tasto, per elettrodi da 4 mm, con spina da KLS Martin
80-332-03-04	1	Electrode neutre en caoutchouc, 8 x 16 cm, avec câble de raccordement de 4 m	Elettrodo neutro di gomma, 8 x 16 cm, cavo di connessione di 4 m
80-372-00-04	1	Bande auto-adhésive, 90 cm	Nastro tessile auto-adesivo, 90 cm
80-505-00-04	1	Tampon de nettoyage pour électrodes, emballage stérile, UC = 100 pièces	Tampone di pulizia per elettrodi, imballaggio sterile, UV = 100 pezzi
80-511-04-04	1	Electrode lancette, coudée	Elettrodo a lancetta, angolato
80-515-04-04	1	Electrode couteau	Elettrodo a bisturi
80-520-04-04	1	Electrode aiguille	Elettrodo ad ago
80-562-04-04	1	Electrode boule, Ø 4 mm	Elettrodo a sfera, Ø 4 mm

Zubehörsätze für Kleingeräte  
 Accessory sets for minor electrosurgery units  
 Juegos de accesorios para aparatos pequeños  
 Jeux d'accessoires pour petits appareils  
 Serie di accessori per apparecchi piccoli

<b>80-150-00-04</b>		<b>Zubehörsatz bipolar für minicutter/ ME 102</b>	<b>Accessory set bipolar for miniCutter/ME 102</b>	<b>Juego de accesorios bipolar para miniCutter/ME 102</b>
80-287-53-04	1	Anschlusskabel für bipolare Pinzetten	Connection cable for bipolar forceps	Cable de conexión para pinzas bipolares
80-924-16-04	1	Bipolare Pinzette, gerade, stumpf, 16 cm	Bipolar forceps, straight, blunt, 16 cm	Pinza bipolar, recta, roma, 16 cm
80-945-20-04	1	Bipolare Pinzette, bajonettförmig, stumpf, 20 cm	Bipolar forceps, bayonet-shaped, blunt, 20 cm	Pinza bipolar, en forma bayoneta, roma, 20 cm
80-925-16-04	1	Bipolare Pinzette, abgewinkelt, stumpf, 16 cm	Bipolar forceps, angled, blunt, 16 cm	Pinza bipolar, acodada, roma, 16 cm
80-925-20-04	1	Bipolare Pinzette, abgewinkelt, stumpf, 20 cm	Bipolar forceps, angled, blunt, 20 cm	Pinza bipolar, acodada, roma, 20 cm
80-924-20-04	1	Bipolare Pinzette, gerade, stumpf, 20 cm	Bipolar forceps, straight, blunt, 20 cm	Pinza bipolar, recta, roma, 20 cm

<b>80-150-01-04</b>		<b>Zubehörsatz bipolar mit non-Stick-red-Pinzetten für Minicutter/ ME 102</b>	<b>Set bipolar accessories with nonStick red forceps for miniCutter/ME 102</b>	<b>Juego de accesorios bipolar con pinzas bipolares nonStick red miniCutter/ME 102</b>
80-287-53-04	1	Anschlusskabel für bipolare Pinzetten	Connection cable for bipolar forceps	Cable de conexión para pinzas bipolares
80-986-17-04	1	Bipolare Pinzette, nonStick red, gerade, stumpf, 16 cm	Bipolar forceps, nonStick red, straight, blunt, 16 cm	Pinza bipolar, nonStick red, recta, roma, 16 cm
80-992-20-04	1	Bipolare Pinzette, nonStick red, bajonettförmig, stumpf, 20 cm	Bipolar forceps, nonStick red, bayonet-shaped, blunt, 20 cm	Pinza bipolar, nonStick red, en forma bayoneta, roma, 20 cm
80-987-17-04	1	Bipolare Pinzette, nonStick red, abgewinkelt, stumpf, 16 cm	Bipolar forceps, nonStick red, angled, blunt, 16 cm	Pinza bipolar, nonStick red, acodada, roma, 16 cm
80-987-20-04	1	Bipolare Pinzette, nonStick red, abgewinkelt, stumpf, 20 cm	Bipolar forceps, nonStick red, angled, blunt, 20 cm	Pinza bipolar, nonStick red, acodada, roma, 20 cm
80-986-20-04	1	Bipolare Pinzette, nonStick red, gerade, stumpf, 20 cm	Bipolar forceps, nonStick red, straight, blunt, 20 cm	Pinza bipolar, nonStick red, recta, roma, 20 cm



<b>80-150-00-04</b>		<b>Lot d'accessoires bipolaire pour miniCutter/ME 102</b>	<b>Serie di accessori bipolare per miniCutter/ME 102</b>
80-287-53-04	1	Câble de raccordement pour pinces bipolaires	Cavo di connessione per pinze bipolari
80-924-16-04	1	Pince bipolaire, droite, mousse, 16 cm	Pinza bipolare, retta, smussa, 16 cm
80-945-20-04	1	Pince bipolaire, en forme baïonnette, mousse, 20 cm	Pinza bipolare, a forma baionetta, smussa, 20 cm
80-925-16-04	1	Pince bipolaire, coudée, mousse, 16 cm	Pinza bipolare, angolata, smussa, 16 cm
80-925-20-04	1	Pince bipolaire, coudée, mousse, 20 cm	Pinza bipolare, angolata, smussa, 20 cm
80-924-20-04	1	Pince bipolaire, droite, mousse, 20 cm	Pinza bipolare, retta, smussa, 20 cm

<b>80-150-01-04</b>		<b>Lot d'accessoires bipolaire avec pinces bipolaires nonStick red miniCutter/ME 102</b>	<b>Set bipolar accessories with nonStick red forceps for miniCutter/ME 102</b>
80-287-53-04	1	Câble de raccordement pour pinces bipolaires	Connection cable for bipolar forceps
80-986-17-04	1	Pince bipolaire, nonStick red, droite, mousse, 16 cm	Bipolar forceps, nonStick red, straight, blunt, 16 cm
80-992-20-04	1	Pince bipolaire, nonStick red, en forme baïonnette, mousse, 20 cm	Bipolar forceps, nonStick red, bayonet-shaped, blunt, 20 cm
80-987-17-04	1	Pince bipolaire, nonStick red, coudée, mousse, 16 cm	Bipolar forceps, nonStick red, angled, blunt, 16 cm
80-987-20-04	1	Pince bipolaire, nonStick red, coudée, mousse, 20 cm	Bipolar forceps, nonStick red, angled, blunt, 20 cm
80-986-20-04	1	Pince bipolaire, nonStick red, droite, mousse, 20 cm	Bipolar forceps, nonStick red, straight, blunt, 20 cm

---

Nummern-Index  
Index of order numbers  
Indice de números de referencia  
Index numérique des références de commande  
Elenco dei codici

**14**

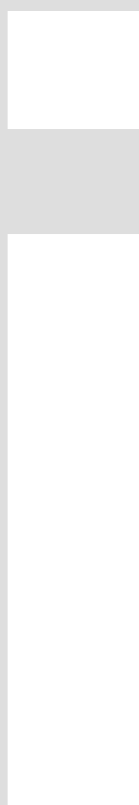



## 08

08-008-00-04.....	170
08-008-00-06.....	170
08-008-00-08.....	170
08-008-00-14.....	170
08-008-00-19.....	170
08-008-00-20.....	170
08-022-00-21.....	170
08-024-00-23.....	184
08-024-00-28.....	184
08-024-00-29.....	184
08-024-00-30.....	184
08-024-00-31.....	184
08-024-00-40.....	184
08-024-00-41.....	184
08-024-00-83.....	184
08-024-00-85.....	184
08-025-00-23.....	184
08-031-10-04.....	186, 187
08-156-00-11.....	191

## 55

55-803-70-04.....	45
55-803-71-04.....	110
55-803-73-04.....	110
55-803-74-04.....	111
55-803-75-04.....	111
55-804-19-01.....	76, 77
55-804-25-01.....	76, 77
55-804-42-01.....	76
55-805-28-01.....	76, 77
55-805-45-01.....	76, 77
55-806-02-04.....	76, 77
55-806-07-04.....	76, 77

## 76

76-100-60-04.....	152, 153
79-225-02-04.....	152, 153
79-225-03-04.....	152, 153
79-225-06-04.....	152, 153
79-225-07-04.....	152, 153
79-225-08-04.....	152, 153
79-225-09-04.....	152, 153
79-225-10-04.....	152, 153
79-225-11-04.....	152, 153
79-800-02-04.....	152, 153

## 80

80-006-02-04.....	163
80-008-03-04.....	56, 163
80-010-02-04.....	56, 162
80-010-02-12.....	162
80-040-00-04.....	56
80-040-11-04.....	56, 162
80-040-11-10.....	162
80-040-12-04.....	56, 162
80-040-12-10.....	162
80-041-01-04.....	56
80-042-00-04.....	56, 142, 143, 160
80-042-02-04.....	56, 142, 143, 160

80-042-04-04.....	56, 142, 143, 160
80-042-10-04.....	202, 203
80-042-11-04.....	206, 207
80-042-12-04.....	210, 211
80-042-20-04.....	202, 203
80-042-21-04.....	206, 207
80-042-22-04.....	210, 211
80-042-40-04.....	204, 205
80-042-41-04.....	208, 209
80-042-42-04.....	210, 211
80-043-00-04.....	56, 142, 143, 161
80-043-01-04.....	56, 142, 143, 161
80-043-02-04.....	56, 142, 143, 161
80-043-10-04.....	142, 143, 161
80-044-00-04.....	142, 143, 160
80-048-00-04.....	142, 143, ..... 186, 187, 188, 189
80-048-01-04.....	186, 187
80-048-02-04.....	186, 187
80-048-03-04.....	142, 143, 186, 187
80-048-04-04.....	142, 143, 186, 187
80-048-05-04.....	142, 143, 186, 187
80-048-06-04.....	186, 187
80-060-00-04.....	148, 149
80-060-00-10.....	148, 149
80-060-01-04.....	148, 149, 150, ..... 151, 152, 153
80-060-02-04.....	155
80-060-03-04.....	154
80-060-04-04.....	152, 153
80-060-05-04.....	152, 153
80-061-00-04.....	148, 149
80-061-00-10.....	148, 149
80-062-00-04.....	150, 151
80-062-00-10.....	150, 151
80-062-01-04.....	150, 151
80-062-01-10.....	150, 151
80-062-05-04.....	150, 151
80-062-06-04.....	150, 151
80-070-00-04.....	190, 191
80-070-01-04.....	191
80-070-02-04.....	190
80-070-03-04.....	190
80-070-04-04.....	190
80-070-05-04.....	191
80-070-06-04.....	190
80-091-01-04.....	152, 153
80-091-02-04.....	152, 153
80-092-00-04.....	160
80-093-00-04.....	120, 160
80-093-01-04.....	160
80-093-02-04.....	160
80-094-00-04.....	161
80-094-01-04.....	161
80-094-02-04.....	161
80-103-00-04.....	170
80-105-00-04.....	168
80-105-01-04.....	168
80-105-02-04.....	168
80-105-03-04.....	168

80-105-05-04.....	168
80-105-06-04.....	169
80-105-07-04.....	169
80-106-01-04.....	212, 213
80-107-00-04.....	212, 213
80-108-00-04.....	216, 217
80-108-01-04.....	216, 217
80-108-02-04.....	216, 217
80-108-03-04.....	214, 215
80-108-04-04.....	214, 215
80-108-05-04.....	214, 215
80-140-00-04.....	194, 195
80-140-02-04.....	198, 199
80-150-00-04.....	194, 195, 218, 219
80-150-01-04.....	196, 197, 218, 219
80-160-00-04.....	198, 199
80-160-01-04.....	198, 199
80-160-02-04.....	200, 201
80-181-02-04.....	22, 132, 142, ..... 143, 144, 145, 206, ..... 207, 208, 209
80-181-05-04.....	133
80-181-07-04.....	135
80-181-08-04.....	135
80-181-10-04.....	133, 142, 143, ..... 206, 207, 208, 209
80-181-11-04.....	133, 142, 143
80-181-12-04.....	134, 144, 145
80-181-13-04.....	135, 142, 143, ..... 206, 207, 208, 209
80-181-14-04.....	135, 142, 143
80-181-15-04.....	135, 142, 143, ..... 206, 207, 208, 209
80-181-16-04.....	135, 142, 143
80-181-17-04.....	140
80-181-23-04.....	138, 144, 145, ..... 210, 211
80-181-24-04.....	138, 144, 145, ..... 210, 211
80-181-25-04.....	138, 144, 145, ..... 210, 211
80-181-26-04.....	138
80-181-27-04.....	138
80-181-28-04.....	138
80-181-29-04.....	138
80-181-30-04.....	136, 144, 145, ..... 210, 211
80-181-31-04.....	136
80-181-32-04.....	138
80-181-41-04.....	139
80-181-42-04.....	139
80-181-43-04.....	139
80-181-44-04.....	139
80-181-50-04.....	141
80-181-51-04.....	141, 144, 145
80-181-52-04.....	141, 142, 143, ..... 206, 207, 209, ..... 210, 211
80-181-53-04.....	141, 143, 206, ..... 210, 211

80-181-54-04.....	141, 142, 143
80-181-55-04.....	141, 142, 143, ..... 208, 210, 211
80-181-56-04.....	141, 142, 143
80-181-57-04.....	141, 142, 143
80-181-60-04.....	134
80-181-62-04.....	134
80-181-90-04.....	132, 136, 140, ..... 144, 145
80-210-02-04.....	200, 201
80-210-03-04.....	19, 23
80-210-12-04.....	17, 22, 155
80-210-13-04.....	10, 14, 202, 203
80-210-16-04.....	19, 23
80-210-18-04.....	10, 14, 204, 205
80-210-21-04.....	12, 15
80-210-23-04.....	12, 15
80-213-01-04.....	21, 115
80-214-00-04.....	21
80-214-01-04.....	21
80-214-10-04.....	20, 23
80-214-11-04.....	20, 23
80-214-12-04.....	13, 15, 212, 213
80-214-13-04.....	13, 15, 212, 213
80-217-01-04.....	20, 22
80-217-02-04.....	16, 22
80-217-05-04.....	13, 14, 214, 215, ..... 216, 217
80-217-12-04.....	16, 22
80-217-13-04.....	10, 14, 194, 195, ..... 198, 199, 202, 203, ..... 216, 217
80-217-32-04.....	18
80-219-42-04.....	17, 22
80-220-00-04.....	16, 22
80-220-02-04.....	11, 14, 196, 197, ..... 214, 215, 216, 217
80-220-30-04.....	18
80-220-31-04.....	11, 14
80-220-40-04.....	18
80-220-41-04.....	11, 14
80-221-02-04.....	19, 23, 198, 199
80-227-00-04.....	12, 14
80-227-01-04.....	12, 14
80-227-02-04.....	12, 14
80-227-03-04.....	12, 14
80-251-00-04.....	121
80-260-50-04.....	187, 202, 203, ..... 204, 205, 206, 207, ..... 208, 209, 210, 211
80-280-30-04.....	21, 115, 126
80-285-40-04.....	46, 114, 127
80-285-50-04.....	46, 114, 127
80-285-51-04.....	117, 129
80-285-55-04.....	46, 115, 127
80-286-30-04.....	60, 62, 67, 75, ..... 83, 85, 118, 128
80-286-40-04.....	67, 75, 83, 85, 128
80-286-50-04.....	60, 62, 67, 75, ..... 83, 85, 118, 128

80-286-60-04.....	118, 128	80-342-07-04.....	51, 56	80-505-00-04.....	27, 194, 195,	.....	196, 197
80-286-80-04.....	119, 129	80-344-09-04.....	54, 56, 198, 199,	.....	196, 197, 198, 199,	80-550-06-04.....	27
80-286-94-04.....	116, 127	.....	200, 201, 202, 203,	.....	200, 201, 202, 203, 204,	80-552-04-04.....	29, 194, 195,
80-286-95-04.....	116, 127	.....	204, 205, 206, 207,	.....	205, 212, 213, 214,	.....	196, 197
80-286-96-04.....	116, 127	.....	208, 209, 210, 211	.....	215, 216, 217	80-560-04-04.....	29, 194, 195, 196,
80-287-33-04.....	60, 62, 67, 75, 83,	80-344-11-04.....	55, 56, 57	80-510-04-04.....	29, 194, 195,	.....	197, 202, 203, 204,
.....	85, 117, 128, 202, 203,	80-344-12-04.....	55, 56, 57	.....	196, 197, 202, 203,	.....	205, 214, 215,
.....	206, 207, 210, 211	80-370-50-04.....	51, 52, 214,	.....	204, 205, 214,	.....	216, 217
80-287-42-04.....	117, 128	.....	215, 216, 217	.....	215, 216, 217	80-560-06-04.....	27
80-287-44-04.....	118, 128	80-371-00-04.....	51, 52, 194, 195,	80-510-06-04.....	26	80-562-04-04.....	29, 194, 195, 196,
80-287-53-04.....	60, 62, 67, 75,	.....	196, 197	80-510-08-04.....	28, 200, 201	.....	197, 198, 199, 214,
.....	83, 85, 117, 128,	80-371-01-04.....	51, 194, 195, 196,	80-510-12-04.....	32	.....	215, 216, 217
.....	194, 195, 196, 197,	.....	197, 214, 215,	80-511-04-04.....	29, 194, 195,	80-562-06-04.....	27
.....	218, 219	.....	216, 217	.....	196, 197, 198, 199,	80-562-08-04.....	28, 200, 201
80-287-60-04.....	117, 128	80-371-02-04.....	52	.....	202, 203, 204, 205,	80-563-04-04.....	29, 194, 195,
80-287-70-04.....	118, 128	80-372-00-04.....	51, 198, 199, 214,	.....	214, 215, 216, 217	.....	196, 197
80-287-72-04.....	61, 63, 67, 75,	.....	215, 216, 217	80-511-06-04.....	26	80-563-05-04.....	43
.....	85, 118, 128	80-408-00-01.....	45, 214, 215,	80-515-04-04.....	29, 194, 195,	80-570-00-04.....	61, 63
.....	85, 118, 128	.....	216, 217	.....	196, 197, 198, 199,	80-570-04-04.....	29, 194, 195,
80-287-80-04.....	119, 129	80-408-00-04.....	214, 216	.....	202, 203, 204, 205,	.....	196, 197
80-287-89-04.....	60, 62, 67, 75, 83,	80-416-00-01.....	45, 194, 195,	80-515-06-04.....	26	80-570-18-04.....	60
.....	85, 119, 128, 202,	.....	196, 197	80-515-08-04.....	28, 200, 201	80-570-21-04.....	60
.....	203, 204, 205, 206,	80-444-08-01.....	45, 212, 213	80-515-12-04.....	32	80-570-23-04.....	60, 202, 203, 204,
.....	207, 208, 209,	80-460-04-04.....	44	80-515-14-04.....	33	.....	205, 206, 207,
.....	210, 211	80-461-01-04.....	38, 212, 213	80-515-16-04.....	33	.....	208, 209
80-287-90-04.....	60, 62, 67, 75,	80-461-02-04.....	38, 212, 213	80-516-04-04.....	29	80-570-28-04.....	60
.....	83, 85, 119, 128	80-461-03-04.....	38	80-516-06-04.....	26	80-571-18-04.....	61
80-287-94-04.....	120, 129	80-461-04-04.....	39	80-519-04-04.....	29	80-571-21-04.....	61
80-287-95-04.....	120, 129	80-461-06-04.....	39	80-520-04-04.....	29, 194, 195,	80-571-23-04.....	61
80-287-96-04.....	120, 129, 168	80-461-07-04.....	39	.....	196, 197, 198, 199,	80-571-28-04.....	61
80-288-53-04.....	117, 129	80-461-11-04.....	39	.....	214, 215, 216, 217	80-572-04-04.....	29
80-288-55-04.....	117, 129	80-461-12-04.....	39, 212, 213	80-520-06-04.....	26	80-572-13-04.....	62
80-288-57-04.....	118, 129	80-461-13-04.....	39	80-520-08-04.....	28, 200, 201	80-572-14-04.....	62
80-288-60-04.....	119, 128	80-461-14-04.....	40, 212, 213	80-520-09-04.....	28	80-572-17-04.....	62
80-288-70-04.....	87	80-461-15-04.....	40, 212, 213	80-520-10-04.....	28	80-574-04-04.....	29
80-288-72-04.....	87	80-461-16-04.....	40	80-521-02-04.....	26	80-580-06-04.....	27
80-288-80-04.....	119, 129	80-461-17-04.....	40	80-521-04-04.....	26	80-610-10-04.....	36
80-289-40-04.....	114, 126, 139,	80-461-18-04.....	40	80-522-04-04.....	26	80-612-10-04.....	36
.....	210, 211	80-461-19-04.....	40	80-525-04-04.....	43	80-630-12-04.....	96, 97
80-289-41-04.....	115, 126, 139	80-461-20-04.....	40	80-530-03-04.....	42	80-630-15-04.....	96, 97, 98, 99
80-289-42-04.....	114, 126	80-461-21-04.....	40	80-530-04-04.....	42	80-630-16-04.....	96, 97, 98, 99
80-290-40-04.....	115, 126	80-461-22-04.....	41	80-531-00-04.....	44	80-630-17-04.....	96, 97, 98, 99
80-291-40-04.....	67, 75, 83, 85, 128	80-461-23-04.....	41	80-532-00-04.....	44	80-630-18-04.....	96, 97, 98, 99
80-293-40-04.....	67, 75, 83, 85, 128	80-461-24-04.....	41	80-533-00-04.....	44	80-630-34-04.....	98, 99
80-294-40-04.....	51, 54, 56, 57,	80-461-31-04.....	41, 212, 213	80-533-01-04.....	44	80-630-35-04.....	98, 99
.....	144, 145, 198,	80-461-32-04.....	41	80-534-06-04.....	34	80-630-41-04.....	96, 97
.....	199, 202, 203, 204,	80-461-33-04.....	42	80-534-12-04.....	34	80-630-42-04.....	98, 99
.....	205, 206, 207, 208,	80-461-34-04.....	42, 212, 213	80-540-04-04.....	29, 194, 195,	80-630-43-04.....	98, 99
.....	209, 210, 211	80-461-35-04.....	42	.....	196, 197, 214, 215,	80-630-45-04.....	96, 97, 98, 99
80-294-43-04.....	51, 54, 56, 57	80-461-36-04.....	42	.....	216, 217	80-630-50-04.....	100, 101
80-294-44-04.....	51, 54, 56, 57,	80-461-37-04.....	42	80-540-12-04.....	33	80-630-51-04.....	100, 101
.....	198, 199, 200, 201,	80-462-01-04.....	38	80-542-04-04.....	29, 194, 195,	80-630-52-04.....	100, 101
.....	206, 207, 210, 211	80-462-02-04.....	38	.....	196, 197, 214, 215,	80-630-53-04.....	100, 101
80-310-04-04.....	53, 212, 213	80-462-11-04.....	39	.....	216, 217	80-630-58-04.....	94, 95, 100, 101
80-332-03-04.....	50, 56, 214, 215,	80-462-12-04.....	39	80-542-06-04.....	27	80-630-59-04.....	100, 101
.....	216, 217	80-462-13-04.....	39	80-542-08-04.....	28, 200, 201	80-630-83-04.....	100, 101
80-342-03-04.....	50, 56, 194, 195,	80-463-01-04.....	38	80-542-12-04.....	33	80-630-90-04.....	100, 101
.....	196, 197, 198, 199	80-464-02-04.....	38	80-545-04-04.....	29	80-630-91-04.....	100, 101
80-342-04-04.....	50, 56	80-464-38-04.....	39	80-550-04-04.....	29, 194, 195,	80-630-92-04.....	100, 101
80-342-05-04.....	50, 56	80-466-01-04.....	38	.....	.....	80-632-00-04.....	94, 95
80-342-06-04.....	52	.....	.....	.....	.....	.....	.....

80-632-01-04.....	94, 95	80-811-30-04.....	144, 145, 176,	80-925-20-04.....	65, 194, 195,	.....	218, 219
80-632-18-04.....	94, 95	.....	178, 180, 198, 199,	.....	218, 219	80-986-20-04.....	70, 196, 197,
80-633-00-04.....	102, 103	.....	200, 201	80-925-22-04.....	65	.....	218, 219
80-633-01-04.....	104, 105	80-811-32-04.....	176, 178, 180	80-931-16-04.....	66	80-986-23-04.....	70
80-633-02-04.....	106, 107	80-811-50-04.....	152, 153, 172, 177,	80-931-18-04.....	66	80-987-12-04.....	71
80-633-03-04.....	108, 109	.....	178, 179, 180,	80-931-20-04.....	66	.....	218, 219
80-633-04-04.....	102, 103, 104,	80-812-10-04.....	172, 179, 212, 213	80-934-12-04.....	64	80-987-17-04.....	71, 196, 197,
.....	105, 106, 107,	80-821-02-04.....	144, 145, 174,	80-934-16-04.....	64	.....	218, 219
.....	108, 109	.....	178, 180	80-934-18-04.....	64	80-987-20-04.....	71, 196, 197,
80-633-05-04.....	102, 103	80-821-03-04.....	174, 178, 180	80-934-20-04.....	64	.....	218, 219
80-633-06-04.....	104, 105	80-821-04-04.....	177, 180	80-934-22-04.....	64	80-987-23-04.....	71
80-633-07-04.....	106, 107	80-821-05-04.....	175, 178, 180	80-934-24-04.....	64	80-988-17-04.....	70
80-633-08-04.....	108, 109	80-823-02-04.....	173, 179, 216, 217	80-934-26-04.....	64	80-988-20-04.....	70
80-633-09-04.....	102, 103, 106, 107	80-824-01-04.....	173, 179	80-934-30-04.....	64	80-988-23-04.....	70
80-633-10-04.....	108, 109	80-825-30-04.....	178, 180	80-935-16-04.....	65	80-988-30-04.....	70
80-633-11-04.....	102, 103, 106, 107	80-830-00-04.....	174, 181, 196, 197	80-935-18-04.....	65	80-989-17-04.....	71
80-633-12-04.....	102, 103, 104, 105,	80-830-01-04.....	175, 181, 202, 203,	80-935-20-04.....	65	80-989-20-04.....	71
.....	106, 107, 108, 109	.....	204, 205, 206, 207,	80-935-22-04.....	65	80-989-23-04.....	71
80-633-13-04.....	102, 103, 104, 105,	80-830-02-04.....	177, 181, 202, 203,	80-935-24-04.....	65	80-989-25-04.....	71
.....	106, 107, 108, 109	.....	204, 205, 206, 207,	80-945-16-04.....	66	80-989-28-04.....	71
80-633-14-04.....	108, 109	80-830-04-04.....	175, 181	80-945-18-04.....	66	80-989-30-04.....	71
80-633-15-04.....	104, 105	80-900-18-03.....	46	80-945-20-04.....	66, 194, 195,	80-990-17-04.....	72
80-633-16-04.....	104, 105	80-900-21-03.....	46	.....	218, 219	80-990-20-04.....	72
80-651-00-04.....	86	80-900-25-03.....	46	80-945-24-04.....	66	80-990-23-04.....	72
80-652-00-04.....	86	80-901-18-03.....	46	80-948-18-04.....	66	80-990-25-04.....	72
80-674-12-04.....	34	80-901-21-03.....	46	80-948-20-04.....	66	80-991-17-04.....	72
80-674-13-04.....	34	80-901-25-03.....	46	80-948-24-04.....	66	80-991-20-04.....	72
80-675-13-04.....	32	80-902-18-03.....	46	80-948-30-04.....	66	80-991-23-04.....	72
80-676-13-04.....	34	80-902-21-03.....	46	80-950-20-04.....	67	80-991-25-04.....	72
80-677-12-04.....	32	80-902-25-03.....	46	80-951-20-04.....	67	80-992-17-04.....	72
80-678-05-04.....	35	80-910-07-04.....	64	80-975-16-04.....	90	80-992-20-04.....	72, 196, 197,
80-678-10-04.....	35	80-910-12-04.....	64	80-975-18-04.....	90	.....	218, 219
80-678-11-04.....	35	80-910-16-04.....	64	80-975-23-04.....	90, 202, 203, 204,	80-992-23-04.....	72
80-680-12-04.....	30	80-910-18-04.....	64	.....	205, 206, 207, 208, 209	80-992-25-04.....	72
80-681-12-04.....	30	80-910-20-04.....	64	80-975-28-04.....	91	80-993-17-04.....	72
80-682-12-04.....	30	80-910-22-04.....	64	80-976-23-04.....	92	80-993-20-04.....	72
80-683-12-04.....	30	80-911-07-04.....	65	80-977-23-04.....	93	80-993-23-04.....	72
80-684-12-04.....	31	80-911-12-04.....	65	80-978-23-04.....	92	80-993-25-04.....	72
80-685-12-04.....	31	80-911-16-04.....	65	80-981-01-04.....	80	80-994-20-04.....	73
80-686-12-04.....	31	80-911-18-04.....	65	80-981-02-04.....	80	80-994-23-04.....	73
80-690-12-04.....	37	80-911-20-04.....	65	80-981-03-04.....	80	80-994-25-04.....	73
80-691-12-04.....	37	80-924-12-04.....	64	80-981-04-04.....	80	80-995-20-04.....	73
80-692-12-04.....	37	80-924-16-04.....	64, 194, 195, 202,	80-981-05-04.....	81	80-995-23-04.....	73
80-693-12-04.....	37	.....	203, 204, 205, 206,	80-981-06-04.....	81	80-996-25-04.....	73
80-694-12-04.....	37	.....	207, 208, 209, 210,	80-981-07-04.....	80	80-997-23-04.....	73
80-695-12-04.....	37	80-924-18-04.....	64	80-981-08-04.....	81	80-997-25-04.....	73
80-790-00-04.....	124	.....	211, 218, 219	80-982-12-04.....	70	80-998-23-04.....	74
80-790-01-04.....	124	80-924-20-04.....	64, 194, 195,	80-982-17-04.....	70	80-998-24-04.....	74
80-790-02-04.....	125	.....	218, 219	80-982-20-04.....	70	80-999-23-04.....	74
80-793-02-04.....	122	80-924-22-04.....	64	80-983-12-04.....	71	80-999-24-04.....	74
80-794-02-04.....	123	80-924-24-04.....	64	80-983-17-04.....	71		
80-795-02-04.....	122	80-924-26-04.....	64	80-984-12-04.....	70	<b>83</b>	
80-795-03-04.....	121	80-924-30-04.....	64	80-984-17-04.....	70	83-120-50-04.....	47, 114, 126, 157
80-795-04-04.....	121	80-925-12-04.....	65	80-984-20-04.....	70	83-120-51-04.....	47, 115, 126, 157
80-796-03-04.....	123	80-925-16-04.....	65, 194, 195,	80-985-12-04.....	71	83-122-50-04.....	114, 126
80-797-00-04.....	178	80-925-18-04.....	218, 219	80-985-17-04.....	71	83-122-60-04.....	114, 126
80-797-01-04.....	178			80-986-12-04.....	70	83-124-50-04.....	115, 126
80-800-00-04.....	125			80-986-17-04.....	70, 196, 197,	83-124-52-04.....	46, 115, 127
80-811-04-04.....	172, 176, 178,					83-520-39-04.....	47
.....	179, 180					83-525-30-04.....	156

83-525-31-04.....	156
83-525-32-04.....	156
83-585-00-04.....	85
83-585-01-04.....	85
83-585-02-04.....	85
83-585-03-04.....	84
83-585-05-04.....	84
83-585-06-04.....	84
83-585-07-04.....	84

## 92

92-800-74-04.....	141
-------------------	-----

## 94

94-179-58-04.....	141
94-179-59-04.....	141

**Алматы** (7273)495-231  
**Ангарск** (3955)60-70-56  
**Архангельск** (8182)63-90-72  
**Астрахань** (8512)99-46-04  
**Барнаул** (3852)73-04-60  
**Белгород** (4722)40-23-64  
**Благовещенск** (4162)22-76-07  
**Брянск** (4832)59-03-52  
**Владивосток** (423)249-28-31  
**Владикавказ** (8672)28-90-48  
**Владимир** (4922) 49-43-18  
**Волгоград** (844)278-03-48  
**Вологда** (8172)26-41-59  
**Воронеж** (473)204-51-73  
**Екатеринбург** (343)384-55-89

**Ижевск** (3412)26-03-58  
**Иваново** (4932)77-34-06  
**Иркутск** (395)279-98-46  
**Казань** (843)206-01-48  
**Калининград** (4012)72-03-81  
**Калуга** (4842)92-23-67  
**Кемерово** (3842)65-04-62  
**Киров** (8332)68-02-04  
**Коломна** (4966)23-41-49  
**Кострома** (4942)77-07-48  
**Краснодар** (861)203-40-90  
**Красноярск** (391)204-63-61  
**Курск** (4712)77-13-04  
**Курган** (3522)50-90-47  
**Липецк** (4742)52-20-81

**Киргизия** (996)312-96-26-47

**Магнитогорск** (3519)55-03-13  
**Москва** (495)268-04-70  
**Мурманск** (8152)59-64-93  
**Набережные Челны** (8552)20-53-41  
**Нижний Новгород** (831)429-08-12  
**Новокузнецк** (3843)20-46-81  
**Ноябрьск** (3496)41-32-12  
**Новосибирск** (383)227-86-73  
**Ноябрьск** (3496)41-32-12  
**Омск** (3812)21-46-40  
**Орел** (4862)44-53-42  
**Оренбург** (3532)37-68-04  
**Пенза** (8412)22-31-16  
**Петрозаводск** (8142)55-98-37  
**Псков** (8112)59-10-37

**Россия** (495)268-04-70

**Пермь** (342)205-81-47  
**Ростов-на-Дону** (863)308-18-15  
**Рязань** (4912)46-61-64  
**Самара** (846)206-03-16  
**Саранск** (8342)22-96-24  
**Санкт-Петербург** (812)309-46-40  
**Саратов** (845)249-38-78  
**Севастополь** (8692)22-31-93  
**Симферополь** (3652)67-13-56  
**Смоленск** (4812)29-41-54  
**Сочи** (862)225-72-31  
**Ставрополь** (8652)20-65-13  
**Сыктывкар** (8212)25-95-17  
**Сургут** (3462)77-98-35  
**Тамбов** (4752)50-40-97

**Казахстан** (772)734-952-31

**Тверь** (4822)63-31-35  
**Тольяти** (8482)63-91-07  
**Томск** (3822)98-41-53  
**Тула** (4872)33-79-87  
**Тюмень** (3452)66-21-18  
**Улан-Удэ** (3012)59-97-51  
**Ульяновск** (8422)24-23-59  
**Уфа** (347)229-48-12  
**Хабаровск** (4212)92-98-04  
**Чебоксары** (8352)28-53-07  
**Челябинск** (351)202-03-61  
**Череповец** (8202)49-02-64  
**Чита** (3022)38-34-83  
**Якутск** (4112)23-90-97  
**Ярославль** (4852)69-52-93